

# TM 10-5430-243-12&P

## TECHNICAL MANUAL

OPERATOR AND UNIT MAINTENANCE MANUAL  
(INCLUDING REPAIR PARTS AND SPECIAL TOOLS LIST)

TANK, FABRIC, COLLAPSIBLE; WATER STORAGE,  
20,000 AND 50,000 GALLONS

### 20,000 GALLONS

MODEL GTA-20KW	NSN 5430-01-485-8341
MODEL RCF-20-K-W-OB	NSN 5430-01-487-0633
MODEL MPC-W-20K-22276	NSN 5430-01-487-0637

### 50,000 GALLONS

MODEL GTA-50KW	NSN 5430-01-485-8339
MODEL RCF-50-K-W-OB	NSN 5430-01-486-8207
MODEL MPC-W-50K-22636	NSN 5430-01-486-8208

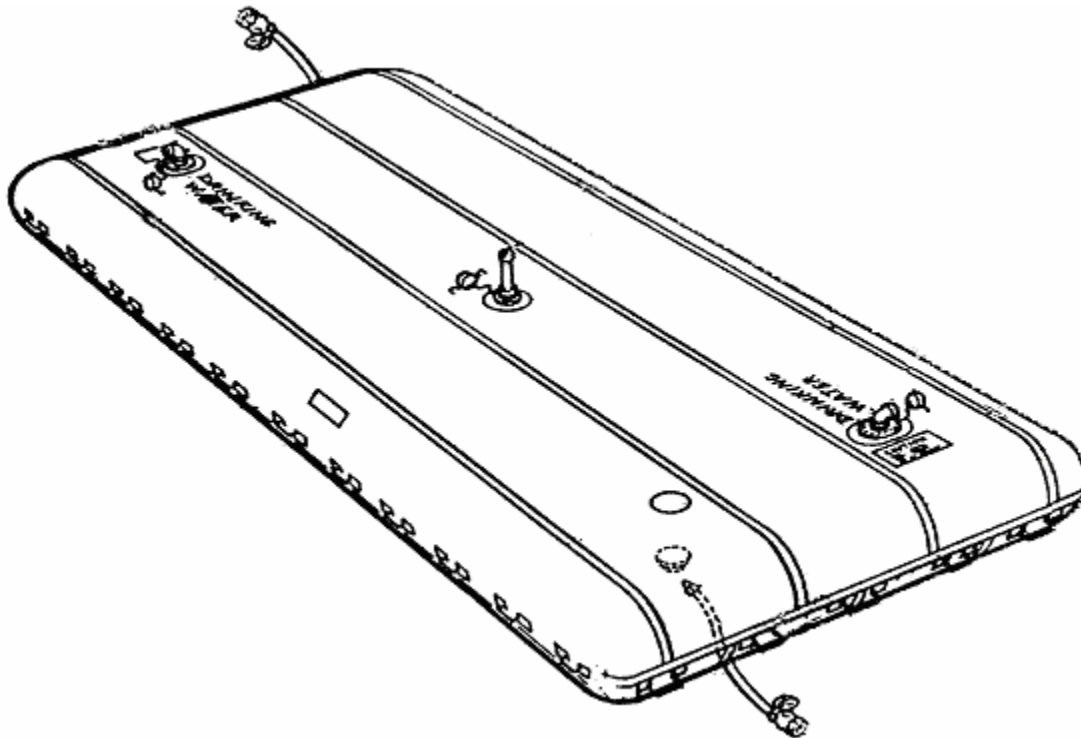

DISTRIBUTION STATEMENT A: Approved for public release; distribution is unlimited.

HEADQUARTERS, DEPARTMENT OF THE ARMY

JANUARY 2002



## WARNING SUMMARY

This warning summary contains general safety warnings and hazardous materials warnings that must be understood and applied during operation and maintenance of this equipment. Failure to observe these precautions could result in serious injury or death to personnel.

### WARNINGS

Chemical solvents used for cleaning detached water tank accessories, exposed fasteners, and other metallic parts (when parts have been removed from the tank installation site) are flammable and toxic to skin, eyes, and the respiratory tract. Skin and eye protection are required. Use chemical solvents in a well ventilated area. Solvent must not come into contact with the tank fabric during any cleaning process. Solvent will contaminate water inside the tank and result in illness or death.

Do not clean parts attached to the tank unless solvent is 100 percent water and mild detergent mixture. Rinse all detached parts thoroughly with detergent and water before parts are reassembled on tank. Wash exposed skin thoroughly. Chemical solvents used for cleaning parts are potentially dangerous to both personnel and property.

Use tank for drinking water only. Other liquids will contaminate tank and could result in illness or death.

Avoid prolonged breathing of solvent vapors, and minimize skin contact. Keep solvents away from excessive heat, open flame, or other sources of ignition.

Do not overfill tank. Make sure filler assembly coupling is installed correctly on the tank or coupling may burst and cause personal injury. Do not exceed 30 psi when drying tank. Do not open coupling arms when water is being transferred into or out of the tank.

Do not set up the tank on sloping ground. Water collecting at one end may cause it to roll over, causing injury.

Filler assembly must be tight. Under pressure, coupling may burst and cause personal injury.

Do not enter tank. Suffocation could result.

Do not permit bolts, washers, gaskets, small items, dirt or foreign matter to fall into tank. Contamination could result in illness or death.

Lifting or moving water tanks, ground cloths, or heavy equipment incorrectly can cause serious injury. Do not lift or move more than 50 pounds (22.7 kg) alone. Always get help from additional personnel during lifting operations.

**FOR ARTIFICIAL RESPIRATION, REFER TO FM 21-11.**



CHANGE  
NO. 1

HEADQUARTERS, DEPARTMENT OF THE ARMY  
WASHINGTON, DC, 28 APRIL 2002

TECHNICAL MANUAL

OPERATOR AND UNIT MAINTENANCE MANUAL  
(INCLUDING REPAIR PARTS AND SPECIAL TOOLS LIST)  
FOR  
TANK, FABRIC, COLLAPSIBLE, WATER STORAGE,  
20,000 AND 50,000 GALLONS

MODEL GTA-20KW	NSN 5430-01-485-8341
MODEL RCF-20-K-W-OB	NSN 5430-01-487-0633
MODEL MPC-W-20K-22276	NSN 5430-01-487-0637
MODEL GTA-50KW	NSN 5430-01-485-8339
MODEL RCF-50-K-W-OB	NSN 5430-01-486-8207
MODEL MPC-W-50K-22636	NSN 5430-01-486-8208

**DISTRIBUTION STATEMENT A.** Approved for public release; distribution is unlimited.

TM 10-5430-243-12&P, 15 January 2002, is updated as follows:

1. File this sheet in front of the manual for reference.
2. This change is a result of new water manual models added to field.
3. New or updated text is indicated by a vertical bar in the outer margin of the page.
4. Added illustrations are indicated by a vertical bar adjacent to the figure number. Changed illustrations are indicated by a miniature pointing hand adjacent to the updated area and a vertical bar adjacent to the figure number.
5. Cover is changed to reflect additions of tank models MPC-W-20K-22276 and MPC-W-50K-22636.
6. Remove old pages and insert new pages as indicated below.

Remove Pages

A/B blank  
Title page  
i through iii/iv blank  
INDEX-1 through INDEX-4  
Cover

Insert Pages

A/B blank  
Title page  
i through iii/iv blank  
INDEX-1 through INDEX-5/6 blank  
Cover

7. Replace the following work packages with the revised version.

Work Package Number

WP 0001 00  
WP 0002 00  
WP 0003 00  
WP 0004 00  
WP 0005 00  
WP 0007 00  
WP 0008 00  
WP 0009 00  
WP 0010 00  
WP 0011 00  
WP 0013 00  
WP 0018 00

Work Package Number

WP 0019 00  
WP 0020 00  
WP 0022 00  
WP 0025 00  
WP 0027 00  
WP 0028 00  
WP 0034 00  
WP 0035 00  
WP 0036 00  
WP 0037 00  
WP 0038 00  
WP 0041 00

**By Order of the Secretary of the Army:**

ERIC K. SHINSEKI  
*General, United States Army*  
*Chief of Staff*

Official:

  
JOEL B. HUDSON  
*Administrative Assistant to the*  
*Secretary of the Army*  
0203002

DISTRIBUTION: To be distributed in accordance with the initial distribution number (IDN) 256705 requirements for TM 10-5430-243-12&P.

INSERT LATEST CHANGED PAGES/WORK PACKAGES. DESTROY SUPERSEDED DATA.

**LIST OF EFFECTIVE PAGES/WORK PACKAGES**

NOTE: The portion of text affected by the changes is indicated by a vertical line in the outer margins of the page. Changes to illustrations are indicated by miniature pointing hands.

Dates of issue for original and changed pages/work packages are:

Original ..0..15 Jan 02

Change ..1..28 Apr 02

**TOTAL NUMBER OF PAGES FOR FRONT AND REAR MATTER IS 30 AND TOTAL NUMBER OF WORK PACKAGES IS 41, CONSISTING OF THE FOLLOWING:**

Page/WP No.	*Change No.	Page/WP No.	*Change No.
Warnings	0	WP 0023 00 (2 pages)	0
A/B blank	1	WP 0024 00 (2 pages)	0
Title	0	WP 0025 00 (4 pages)	1
i-iii/iv blank	1	WP 0026 00 (4 pages)	0
WP 0001 00 (2 pages)	1	WP 0027 00 (4 pages)	1
Chapter 1 title page	0	WP 0028 00 (2 pages)	1
WP 0002 00 (8 pages)	1	WP 0029 00 (2 pages)	0
WP 0003 00 (2 pages)	1	WP 0030 00 (2 pages)	0
Chapter 2 title page	0	WP 0031 00 (2 pages)	0
WP 0004 00 (4 pages)	1	Chapter 6 title page	0
WP 0005 00 (18 pages)	1	WP 0032 00 (2 pages)	0
WP 0006 00 (6 pages)	0	WP 0033 00 (6 pages)	0
WP 0007 00 (2 pages)	1	WP 0034 00 (6 pages)	1
Chapter 3 title page	0	WP 0035 00 (38 pages)	1
WP 0008 00 (8 pages)	1	WP 0036 00 (2 pages)	1
WP 0009 00 (8 pages)	1	WP 0037 00 (4 pages)	1
Chapter 4 title page	0	WP 0038 00 (12 pages)	1
WP 0010 00 (8 pages)	1	WP 0039 00 (2 pages)	0
WP 0011 00 (2 pages)	1	WP 0040 00 (4 pages)	0
WP 0012 00 (2 pages)	0	WP 0041 00 (2 pages)	1
WP 0013 00 (2 pages)	1		
WP 0014 00 (2 pages)	0	Glossary 1 thru Glossary 2	0
WP 0015 00 (2 pages)	0	Index 1 thru Index 6	1
Chapter 5 title page	0		
WP 0016 00 (2 pages)	0		
WP 0017 00 (2 pages)	0		
WP 0018 00 (4 pages)	1		
WP 0019 00 (8 pages)	1		
WP 0020 00 (2 pages)	1		
WP 0021 00 (6 pages)	0		
WP 0022 00 (2 pages)	1		

\*Zero in this column indicates an original page or work package.





HEADQUARTERS,  
DEPARTMENT OF THE ARMY  
WASHINGTON, D.C., 15 January 2002

## TECHNICAL MANUAL

### OPERATOR AND UNIT MAINTENANCE MANUAL (INCLUDING REPAIR PARTS AND SPECIAL TOOLS LIST)

#### TANK, FABRIC, COLLAPSIBLE; WATER STORAGE, 20,000 AND 50,000 GALLONS

##### 20,000 GALLONS

MODEL GTA-20KW	NSN 5430-01-485-8341
MODEL RCF-20-K-W-OB	NSN 5430-01-487-0633
MODEL MPC-W-20K-22276	NSN 5430-01-487-0637

##### 50,000 GALLONS

MODEL GTA-50KW	NSN 5430-01-485-8339
MODEL RCF-50-K-W-OB	NSN 5430-01-486-8207
MODEL MPC-W-50K-22636	NSN 5430-01-486-8208

Current as of 01 March 2002

#### REPORTING ERRORS AND RECOMMENDING IMPROVEMENTS

You can help improve this publication. If you find any mistakes or if you know of a way to improve the procedures, please let us know. Submit your DA Form 2028 (Recommended Changes to Publications and Blank Forms), through the Internet, on the Army Electronic Product Support (AEPS) website. The Internet address is <http://aeeps.ria.army.mil>. If you need a password, scroll down and click on "ACCESS REQUEST FORM". The DA Form 2028 is located in the ONLINE FORMS PROCESSING section of the AEPS. Fill out the form and click on SUBMIT. Using this form on the AEPS will enable us to respond quicker to your comments and better manage the DA Form 2028 program. You may also mail, fax or E-mail your letter, or DA Form 2028 direct to: AMSTA-LC-CI/TECH PUBS, TACOM-RI, 1 Rock Island Arsenal, Rock Island, IL 61299-7630. The email address is TACOM-TECH-PUBS@ria.army.mil. The fax number is DSN 793-0726 or Commercial (309) 782-0726.

**DISTRIBUTION STATEMENT A** – Approved for public release; distribution is unlimited.



# TABLE OF CONTENTS

WP Sequence No.

WARNING SUMMARY

HOW TO USE THIS MANUAL

General Information .....	0001 00
CHAPTER 1 – Description and Theory of Operation	
Equipment Description and Data .....	0002 00
Theory of Operation .....	0003 00
CHAPTER 2 – Operator Instructions	
Description and Use of Controls and Indicators .....	0004 00
Operation Under Usual Conditions .....	0005 00
Operation Under Unusual Conditions .....	0006 00
Decals and Instruction Plates .....	0007 00
CHAPTER 3 – Troubleshooting Procedures	
Operator Troubleshooting Procedures .....	0008 00
Unit Troubleshooting Procedures .....	0009 00
CHAPTER 4 – Operator Maintenance Instructions	
Operator PMCS Procedures .....	0010 00
Operator Maintenance Procedures .....	0011 00
Filler/Discharge Gate Valve (GTA Container Model), Hose Assembly Coupling and Dust Cap Gasket Replacement .....	0012 00
Filler/Discharge Ball Valve Gasket (Reliance and MPC Models) Replacement .....	0013 00
Vent Fitting Assembly Coupling and Dust Cap Gasket Replacement .....	0014 00
Filler/Discharge Assembly Elbow and Dust Cap Gasket Replacement .....	0015 00
CHAPTER 5 – Unit Maintenance Instructions	
Lubrication Instructions .....	0016 00
Unit Repair; Tools; Special Tools; Test, Measurement and Diagnostic Equipment (TMDE); and Support Equipment .....	0017 00
Unit Service Upon Receipt .....	0018 00
Unit PMCS Procedures .....	0019 00
Unit Maintenance Procedures .....	0020 00
Filler/Discharge Gate Valve Assembly (GTA Container Model) Removal, Service, Repair and Installation .....	0021 00
Filler/Discharge Ball Valve Assembly (Reliance and MPC Models) Removal, Service, Repair and Installation .....	0022 00
Filler/Discharge Hose Assembly Removal, Service and Installation .....	0023 00
Drain Hose Assembly Removal, Service and Installation .....	0024 00
Vent Fitting Assembly Removal, Service, Repair and Installation .....	0025 00
Filler/Discharge Assembly (GTA Container Model) Removal, Service, Repair and Installation .....	0026 00
Filler/Discharge Assembly (Reliance and MPC Models) Removal, Service, Repair and Installation .....	0027 00
Drain Fitting Assembly Service and Repair .....	0028 00
Ground Cloth Maintenance .....	0029 00
Emergency Repair Kit Maintenance .....	0030 00
Preparation for Storage or Shipment .....	0031 00

CHAPTER 6 – Supporting Information

References.....	0032 00
Maintenance Allocation Chart.....	0033 00
Repair Parts and Special Tools List Introduction.....	0034 00
Repair Parts List.....	0035 00
National Stock Number Index.....	0036 00
Part Number Index.....	0037 00
Components of End Item (COEI) and Basic Issue Items (BII) Lists.....	0038 00
Expendable and Durable Items List.....	0039 00
Torque Limits.....	0040 00
Mandatory Replacement Parts List.....	0041 00

GLOSSARY

INDEX

## HOW TO USE THIS MANUAL

Section I. OVERVIEW – This manual is divided into six chapters consisting of 41 work packages that provide all the information necessary to operate and maintain the collapsible fabric water tank assemblies.

Section II. INDEXING – This manual contains several types of indexes to help the user locate information quickly and efficiently. The different indexes are as follows:

- a. Table of Contents. Lists all chapters and work packages contained in the manual, along with the work package numbers where they begin.
- b. Alphabetical Index. Located at the back of the manual, this index lists entries that personnel are most likely to look for. Most listings are provided several times in the index (i.e., “Maintenance Forms, Records and Reports” can also be found as “Forms, Records and Reports, Maintenance,” and “Records and Reports, Maintenance Forms,”). This increases the likelihood of finding the information immediately. Each entry also lists the work package where the information can be found.



---

**OPERATOR AND UNIT MAINTENANCE MANUAL  
(INCLUDING REPAIR PARTS AND SPECIAL TOOLS LIST)  
TANK, FABRIC, COLLAPSIBLE, WATER STORAGE,  
20,000 AND 50,000 GALLONS  
GENERAL INFORMATION**

---

## SCOPE

This technical manual contains instructions for operations, checks and corrective maintenance for the 20,000 and 50,000 Gallon Water Storage Collapsible Fabric Tanks.

Type of Manual: Operator and Unit Maintenance.

Model Number and Equipment Names: GTA-20KW, RCF-20-K-W-OB and MPC-W-20K-22276, 20,000 Gallon Water Storage Collapsible Fabric Tanks, plus GTA-50KW, RCF-50-K-W-OB and MPC-W-50K-22636, 50,000 Gallon Water Storage Collapsible Fabric Tanks.

Purpose of Equipment: The 20,000 and 50,000 gallon collapsible fabric tanks are utilized as part of a water distribution system to store and distribute potable drinking water throughout the system.

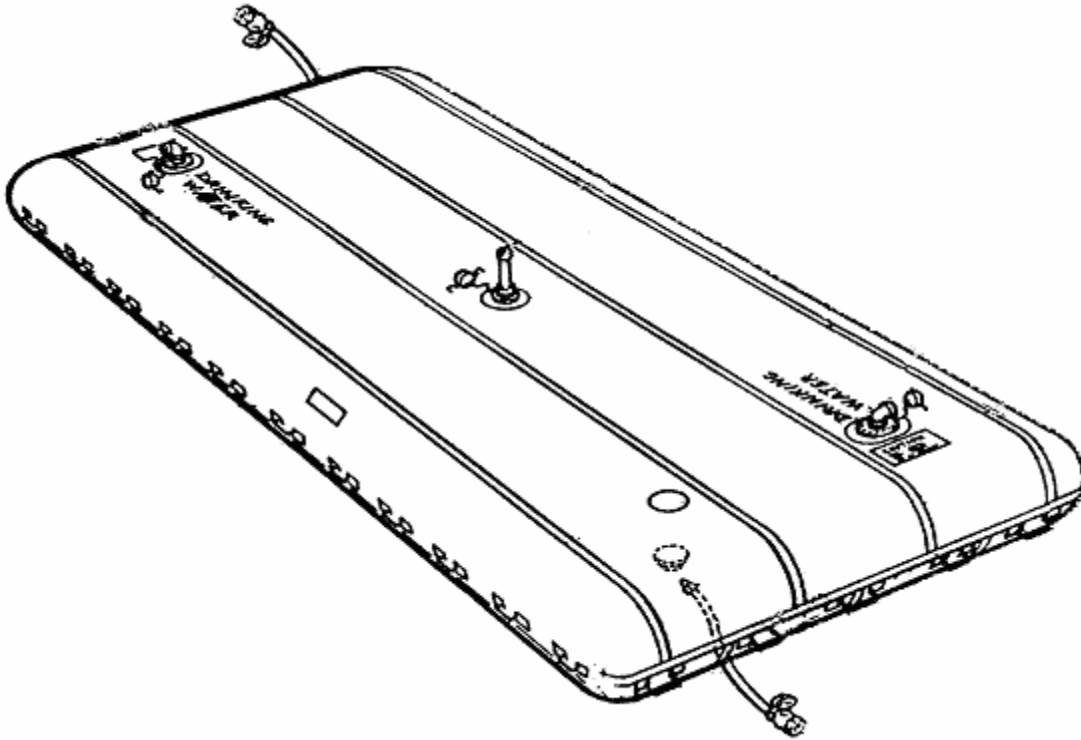

**NOTE:** Model GTA-50KW shown, others similar.

## MAINTENANCE FORMS, RECORDS AND REPORTS

Department of the Army forms and procedures used for equipment maintenance will be those prescribed by (as applicable) DA Form 2404, Equipment Inspection and Maintenance Worksheet, DA Form 2407, Maintenance Request, DA Form 2407-1, Maintenance Request Continuation Sheet, DA PAM 738-750, Functional Users Manual for the Army Maintenance Management System (TAMMS); DA PAM 738-751, Functional Users Manual for The Army Maintenance Management System Aviation (TAMMS-A); or AR 700-138, Army Logistics Readiness and Sustainability.

**REPORTING EQUIPMENT IMPROVEMENT RECOMMENDATIONS (EIRs)**

If any collapsible fabric water tank assembly needs improvement, let us know. Send us an EIR. You, the user, are the only one who can tell us what you don't like about your equipment. Let us know why you don't like the design or performance. Put it on an SF 368 (Product Quality Deficiency Report). Mail it to the address specified in DA PAM 738-750, Functional Users Manual for the Army Maintenance Management System (TAMMS), or as specified by the acquiring activity. We will send you a reply.

**CORROSION PREVENTION AND CONTROL (CPC)**

Corrosion Prevention and Control (CPC) of Army materiel is a continuing concern. It is important that any corrosion problems with this item be reported so that the problem can be corrected and improvements can be made to prevent the problem in future items.

While corrosion is typically associated with rusting of metals, it can also include deterioration of other materials, such as rubber and plastic. Unusual cracking, softening, swelling, or breaking of the materials may be a corrosion problem.

If a corrosion problem is identified, it can be reported using Standard Form 368, Product Quality Deficiency Report. Use of key words such as "rust," "deterioration," "corrosion," or "cracking" will make sure that the information is identified as a CPC problem. The form should be submitted to the address specified in DA PAM 738-750.

**DESTRUCTION OF ARMY MATERIEL TO PREVENT ENEMY USE**

Command decisions, according to tactical situations, will determine when destruction of the collapsible fabric water tank assembly will be accomplished. A destruction plan will be prepared by the using organization, unless higher authority has prepared one. For general destruction procedures for this equipment, refer to TM 750-244-3, Procedures for Destruction of Equipment to Prevent Enemy Use.

**PREPARATION FOR STORAGE OR SHIPMENT**

Refer to WP 0031 00.

**QUALITY ASSURANCE/QUALITY CONTROL (QA/QC)**

Workmanship shall be of the highest quality and shall permit no defects and must be repaired in accordance with the instructions in this manual. All metal parts shall be clean and free of sand, dirt, etc. The inside and outside of the tank shall be clean and free of foreign material.

**END OF WORK PACKAGE**



**CHAPTER 1**

**DESCRIPTION AND THEORY OF OPERATION  
FOR  
TANK, FABRIC, COLLAPSIBLE, WATER STORAGE,  
20,000 and 50,000 GALLONS**



---

**OPERATOR AND UNIT MAINTENANCE MANUAL  
(INCLUDING REPAIR PARTS AND SPECIAL TOOLS LIST)  
TANK, FABRIC, COLLAPSIBLE, WATER STORAGE,  
20,000 AND 50,000 GALLONS  
EQUIPMENT DESCRIPTION AND DATA**

---

### **EQUIPMENT CHARACTERISTICS, CAPABILITIES, AND FEATURES**

Characteristics, capabilities, and features of the 20K and 50K collapsible fabric water tank assemblies include:

- a. Easily transportable when empty and quickly sets up in the field. Primarily used in quick-response deployment operations. Provides long life in both hot and cold climates.
- b. Collapsible container designed to store potable water only. It will store water that is off-loaded from shipping tankers or pumped from wells. When filled, the tank assumes a pillow shape with the length and width decreasing inward from flat dimensions approximately one foot each and gaining in height four to five feet.
- c. The self-erecting pillow-shaped water tank is provided with a safety vent to prevent overfilling and quick disconnect couplings and fittings to allow for rapid connection of system water hoses.
- d. Handles aid positioning and movement of empty tank.
- e. Compatible with all standard military water storage and handling equipment.
- f. Tank is self-supporting and does not require earth embankment support on level ground.
- g. Tank is composed of a reinforcing fabric impregnated with an elastomeric coating on both sides, which is suitable for drinking water. The tank materials are designed to resist exposure effects from extreme temperatures, rain, snow, ice, fungi growth and high humidity conditions.
- h. Five fittings are bonded into the tank for attaching a vent fitting assembly, two filler/discharge assemblies, and two drain assemblies.
- i. A vent fitting assembly is integral to the tank on top center to relieve pressure as the tank is filled.
- j. Small cuts and holes easily repaired with the kit supplied.
- k. All tank models are equipped with a ground cloth to protect the tank bottom from punctures.

### **LOCATION AND DESCRIPTION OF MAJOR COMPONENTS**

Refer to WP 0004 00.

### **DIFFERENCES BETWEEN MODELS**

The 20K and 50K tank models are similar except for variations in size and weight. The 20,000 Gallon (75,710-liter) tank has a different envelope from that of the 50,000 Gallon (189,300-liter) tank, but functions the same and has very similar fittings. Each unit consists of an elastomeric-coated collapsible fabric water tank with two filler/discharge assemblies with elbow fittings, a vent fitting assembly with vent relief cap, a drain valve assembly with 8.0 foot (2.44 meter) drain hose and ball valve, a 10.0-foot (3.05 meter) filler/discharge hose assembly with ball/gate valve, a tank repair kit containing emergency repair items, a spare parts package consisting of o-rings and gaskets, and, for Reliance and MPC tank models, two lift slings. A separate nylon coated fabric ground cloth protects the tank bottom from punctures on all tank models.

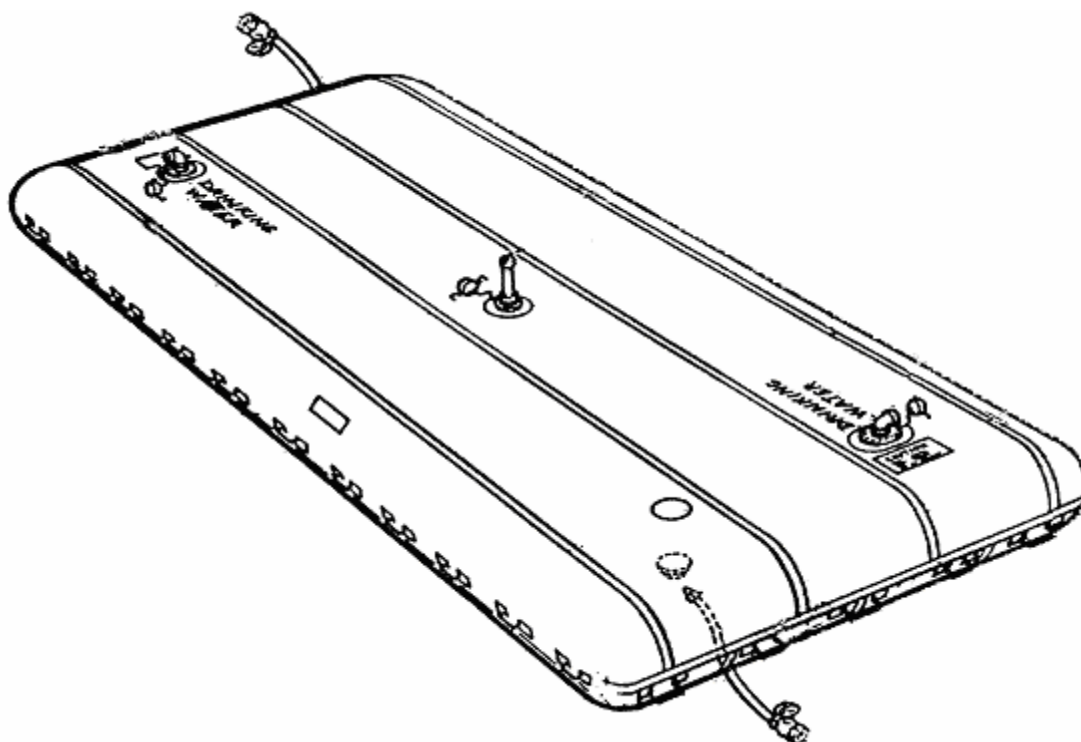

**NOTE**

Model GTA-50KW shown; other tanks are similar.

**OPERATING INSTRUCTIONS ON INSTRUCTION PLATES AND DECALS**

Instruction plates are provided on the collapsible fabric water tank. Stencils containing information previously provided by decals are at multiple locations on all tank models. Refer to WP 0007 00.

**DECAL MARKINGS**

Permanent stencils have replaced decal markings on all collapsible water tanks, as noted below:

Identification Stencil. The tanks are marked with an identification stencil, which lists the following:

- TANK, FABRIC, COLLAPSIBLE:
- (20,000 or 50,000 GALLONS) DRINKING WATER
- NSN:
- MANUFACTURER:
- MANUFACTURE DATE:
- CONTRACT NO.:
- LOT & SERIAL NO.:
- WEIGHT EMPTY:
- CRATED WEIGHT:

Torque Requirement Stencil. The following information regarding torque requirements shall be located adjacent to each fitting assembly:

MAXIMUM TORQUE (GTA Container Tanks) .....	16.0 foot-pounds
MAXIMUM TORQUE (MPC Tanks) .....	16.0 foot-pounds
MAXIMUM TORQUE (Reliance Coated Fabric Tanks) .....	15.0 foot-pounds

Caution Stencil. The following information shall be located adjacent to each fitting assembly:

**CAUTION**

**DO NOT OVERFILL**

**OVERFILLING WILL RESULT IN PERMANENT  
DAMAGE AND FAILURE OF THE TANK.**

**MAXIMUM CAPACITY: (20,000 or 50,000 GALLONS)**

**MAXIMUM TANK HEIGHT: (WHEN FULL)**

**NOT RECOMMENDED FOR LONG TERM WATER STORAGE**

Drain Fitting Stencil. The following information shall be stenciled on the top of the tank to show the location of each drain fitting along with hose connection instructions:

**DRAIN FITTING LOCATED UNDER THIS LABEL**

**CONNECT DRAIN HOSE BEFORE FILLING TANK**

Drinking Water Stencil. Information shall be stenciled in permanent 4-inch (minimum height) lettering on the sides of the tank. Depending upon tank model, the stencil must state one of the following:

**DRINKING WATER**  
or  
**DRINKING WATER ONLY**

**EQUIPMENT DATA**

20,000 - GALLON TANK

**CAUTION**

**If the tank is used in temperatures below freezing [32°F (0°C)], caution must be used to prevent water in the tank, or in contact with metal parts, from freezing. If water freezes, damage may occur to the tank and/or metal parts.**

OPERATING TEMPERATURE (AMBIENT) for MODEL GTA-20KW:

LOW ..... 32°F (0°C)  
HIGH ..... +130°F (+54.5°C)

STORAGE TEMPERATURE (AMBIENT) for MODEL GTA-20KW:

LOW ..... -28°F (-33.4°C)  
HIGH ..... +160°F (+71.1°C)

DIMENSIONS, OUTSIDE, for MODEL GTA-20KW (Packaged):

HEIGHT ..... 20.0 inches (50.8 cm)  
WIDTH ..... 4.0 feet (1.2 m)  
LENGTH ..... 6.54 feet (2.0 m)  
WEIGHT (CRATED) ..... 1372 pounds (622.9 kg)  
WEIGHT (DRY) ..... 656 pounds (297.8 kg)

DIMENSIONS for MODEL GTA-20KW (Filled):

HEIGHT.....	5.5 feet (1.68 m)
WIDTH.....	24.8 feet (7.56 m)
LENGTH.....	27.9 feet (8.51 m)

DIMENSIONS for MODEL GTA-20KW (Unfolded):

WIDTH.....	25.0 feet (7.63 m)
LENGTH.....	28.0 feet (8.54 m)

DIMENSIONS for MODEL GTA-20KW Ground Cloth:

PART NUMBER.....	GTA-20KGC
LENGTH (Unfolded).....	30.0 feet (9.15 m)
WIDTH (Unfolded).....	30.0 feet (9.15 m)
WEIGHT.....	120 pounds (54.5 m)

WATER STORAGE CAPACITY for MODEL GTA-20KW:..... 20,000 gallons (75,710 liters)

OPERATING TEMPERATURE (AMBIENT) for MODEL RCF-20-K-W-OB:

LOW.....	32°F (0°C)
HIGH.....	+130°F (+54.5°C)

STORAGE TEMPERATURE (AMBIENT) for MODEL RCF-20-K-W-OB:

LOW.....	-28°F (-33.4°C)
HIGH.....	+160°F (+71.1°C)

DIMENSIONS, OUTSIDE, for MODEL RCF-20-K-W-OB (Packaged):

HEIGHT.....	22 inches (55.9 cm)
WIDTH.....	3.0 feet (0.92 m)
LENGTH.....	7.0 feet (2.14 m)
WEIGHT (CRATED).....	1200 pounds (544.8 kg)
WEIGHT (DRY).....	690 pounds (313.3 kg)

DIMENSIONS for MODEL RCF-20-K-W-OB (Filled):

HEIGHT.....	4.0 feet (1.22 m)
WIDTH.....	23.5 feet (7.17 m)
LENGTH.....	27.5 feet (8.39 m)

DIMENSIONS for MODEL RCF-20-K-W-OB (Unfolded):

WIDTH.....	24.0 feet (7.32 m)
LENGTH.....	28.0 feet (8.54 m)

DIMENSIONS for MODEL RCF-20-K-W-OB Ground Cloth:

PART NUMBER.....	RCF-20-K-GC-OB
LENGTH (Unfolded).....	30.0 feet (9.15 m)
WIDTH (Unfolded).....	30.0 feet (9.15 m)
WEIGHT.....	120 pounds (54.5 kg)

WATER STORAGE CAPACITY for MODEL RCF-20-K-W-OB:..... 20,000 gallons (75,710 liters)

OPERATING TEMPERATURE (AMBIENT) for MODEL MPC-W-20K-22276:

LOW.....	32°F (0°C)
HIGH.....	+130°F (+54.5°C)

STORAGE TEMPERATURE (AMBIENT) for MODEL MPC-W-20K-22276:

LOW.....	-25°F (-31.7°C)
HIGH.....	+130°F (+54.5°C)

DIMENSIONS, OUTSIDE, for MODEL MPC-W-20K-22276 (Packaged):

HEIGHT.....	20 inches (50.8 cm)
WIDTH.....	43 inches (109.22 cm)
LENGTH.....	57 inches (144.8 cm)
WEIGHT (CRATED).....	1449 pounds (657.3 kg)
WEIGHT (DRY).....	540 pounds (244.9 kg)

DIMENSIONS for MODEL MPC-W-20K-22276 (Filled):

HEIGHT.....	5.6 feet (1.676 m)
WIDTH.....	23.0 feet (7.01 m)
LENGTH.....	27.0 feet (8.22 m)

DIMENSIONS for MODEL MPC-W-20K-22276 (Unfolded):

WIDTH.....	24.5 feet (± 6 inches) (7.468 m)
LENGTH.....	28.0 feet (± 1 foot) (8.54 m)

DIMENSIONS for MODEL MPC-W-20K-22276 Ground Cloth:

PART NUMBER.....	MPC-W-20K-GC-3131
LENGTH (Unfolded).....	31.66 feet (± 6 inches) (9.65 m)
WIDTH (Unfolded).....	31.66 feet (± 6 inches) (9.65 m)
WEIGHT.....	215 pounds (97.7 kg)

WATER STORAGE CAPACITY for MODEL MPC-W-20K-22276:..... 20,000 gallons (75,710 liters)

**50,000 - GALLON TANK**

OPERATING TEMPERATURE (AMBIENT) for MODEL GTA-50KW:

LOW.....	32°F (0°C)
HIGH.....	+130°F (+54.5°C)

STORAGE TEMPERATURE (AMBIENT) for MODEL GTA-50KW:

LOW.....	-28°F (-33.4°C)
HIGH.....	+160°F (+71.1°C)

DIMENSIONS, OUTSIDE, for MODEL GTA-50KW (Packaged):

HEIGHT.....	25.0 inches (63.5 cm)
WIDTH.....	4.8 feet (1.5 m)
LENGTH.....	7.4 feet (2.26 m)
WEIGHT (CRATED).....	2120 pounds (962.5 kg)
WEIGHT (DRY).....	1255 pounds (569.8 kg)

DIMENSIONS for MODEL GTA-50KW (Filled):

HEIGHT.....	4.83 feet (1.47 m)
WIDTH.....	24.8 feet (7.56 m)
LENGTH.....	64.5 feet (19.7 m)

DIMENSIONS for MODEL GTA-50KW (Unfolded):

WIDTH.....	25 feet (7.63 m)
LENGTH.....	65.5 feet (19.9 m)

DIMENSIONS for MODEL GTA-50KW Ground Cloth:

PART NUMBER.....	GTA-50GC
LENGTH (Unfolded).....	68.0 feet (20.74 m)
WIDTH (Unfolded).....	28.0 feet (8.54 m)
WEIGHT.....	290 pounds (131.66 kg)

WATER STORAGE CAPACITY for MODEL GTA-50KW: ..... 50,000 gallons (189,300 liters)

OPERATING TEMPERATURE (AMBIENT) for MODEL RCF-50-K-W-OB:

LOW ..... 32°F (0°C)  
HIGH ..... +130°F (+54.5°C)

STORAGE TEMPERATURE (AMBIENT) for MODEL RCF-50-K-W-OB:

LOW ..... -28°F (-33.4°C)  
HIGH ..... +160°F (+71.1°C)

DIMENSIONS, OUTSIDE, for MODEL RCF-50-K-W-OB (Packaged):

HEIGHT (Folded) ..... 32 inches (81.3 cm)  
WIDTH..... 3 feet (0.92 m)  
LENGTH..... 7.5 feet (2.3 m)  
WEIGHT (CRATED)..... 2300 pounds (1044.2 kg)  
WEIGHT (DRY)..... 1400 pounds (635.6 kg)

DIMENSIONS for MODEL RCF-50-K-W-OB (Filled):

HEIGHT ..... 4.0 feet (1.22 m)  
WIDTH..... 24 feet (7.3 m)  
LENGTH..... 63 feet (19.2 m)

DIMENSIONS for MODEL RCF-50-K-W-OB (Unfolded):

WIDTH..... 25 feet (7.6 m)  
LENGTH..... 65 feet (19.8 m)

DIMENSIONS for MODEL RCF-50-K-W-OB Ground Cloth:

PART NUMBER ..... RCF-50-K-GC-OB  
LENGTH (Unfolded)..... 68.0 feet (20.74 m)  
WIDTH (Unfolded)..... 28.0 feet (8.54 m)  
WEIGHT ..... 290 pounds (131.66 kg)

WATER STORAGE CAPACITY for MODEL RCF-50-K-W-OB: ..... 50,000 gallons (189,300 liters)

OPERATING TEMPERATURE (AMBIENT) for MODEL MPC-W-50K-22636:

LOW ..... 32°F (0°C)  
HIGH ..... +130°F (+54.5°C)

STORAGE TEMPERATURE (AMBIENT) for MODEL MPC-W-50K-22636:

LOW ..... -25°F (-31.7°C)  
HIGH ..... +130°F (+54.5°C)

DIMENSIONS, OUTSIDE, for MODEL MPC-W-50K-22636 (Packaged):

HEIGHT (Folded) ..... 25 inches (63.5 cm)  
WIDTH..... 56 inches (142.2 cm)  
LENGTH..... 79 inches (200.7 cm)  
WEIGHT (CRATED)..... 2245 pounds (1018.0 kg)  
WEIGHT (DRY)..... 1090 pounds (494.4 kg)

DIMENSIONS for MODEL MPC-W-50K-22636 (Filled):

HEIGHT ..... 5.6 feet (1.676 m)  
WIDTH..... 23 feet (7.01 m)  
LENGTH..... 64.5 feet (19.66 m)



DIMENSIONS for MODEL MPC-W-50K-22636 (Unfolded):

WIDTH.....24.5 feet (± 6 inches) (7.47 m)  
LENGTH..... 65.0 feet (± 1 foot) (19.8 m)

DIMENSIONS for MODEL MPC-W-50K-22636 Ground Cloth:

PART NUMBER ..... MPC-W-50K-GC-3167  
LENGTH (Unfolded).....67.66 feet (20.62 m)  
WIDTH (Unfolded).....31.66 feet (9.65 m)  
WEIGHT .....461 pounds (209.54 kg)

WATER STORAGE CAPACITY for MODEL MPC-W-50K-22636:..... 50,000 gallons (189,300 liters)

**END OF WORK PACKAGE**



---

**OPERATOR AND UNIT MAINTENANCE MANUAL  
(INCLUDING REPAIR PARTS AND SPECIAL TOOLS LIST)  
TANK, FABRIC, COLLAPSIBLE, WATER STORAGE,  
20,000 AND 50,000 GALLONS  
THEORY OF OPERATION**

---

## **THEORY OF OPERATION**

The 20K and 50K collapsible water tanks described in this manual are functional components of a water distribution system. Any number of tanks may be connected to the system, depending on operational requirements. Only two operator controls are utilized on the water tanks. They are: (1) the gate (or ball) valve to control water flow during fill/discharge, and (2) the drain ball valve to control draining. For tank models manufactured by GTA Container, a gate valve is used to control water flow. For tank models manufactured by Reliance and MPC, a ball valve is used to control water flow. For specific operating instructions, refer to Chapter 2.

## **FILLING**

Potable water to fill the water tank is supplied by a water distribution system. The system water pumps draw water from the source (tanker truck, pipeline, or purification equipment) and pumps it into the water tank through the filler assembly. Control of water flow between the supply pumps and the water tank is accomplished by opening or closing gate valves within the system supply circuit. As the water tank fills, the tank will enlarge. When the tank is full or no additional water is needed, supply circuit gate valves are then closed. Excessive pressure caused by overfilling the tank is relieved by the vent fitting assembly. The vent relief cap unseats when internal water pressure exceeds 0.10 psi (0.00680 atmospheres). The 4-inch gate or ball valve and 4-inch X 10 foot filler/discharge hose assembly supplied with the tank may be installed on the filler elbow to control the water tank fill rate.

## **DISCHARGE**

When needed, water is drawn from the tank by system suction pumps and distributed through a network of valves and hoses to the field installed facilities. As water is drawn from the tank, the tank will flatten. Water flow between the system discharge pumps and the water tank is controlled by the gate valves. The 4-inch gate or ball valve and 4-inch X 10 foot filler/discharge hose assembly supplied with the tank may be installed on the discharge elbow to control the water tank discharge rate. When the tank is empty or no more water is needed, the downstream discharge gate or ball valves are then closed. Venting of the tank during discharge is not required.

## **DRAINING**

A 2-inch X 8 foot drain hose assembly is connected to each tank drain fitting. Ball valves attached to the hoses are used to control water flow from the tank. These drain hose assemblies allow a restricted flow of water from the tank for sampling or complete drainage. When preparing the tank for movement, the system suction pumps will draw most of the water from the tank. To ensure complete drainage, the ball valve is opened.

## **END OF WORK PACKAGE**



**CHAPTER 2**

**OPERATOR INSTRUCTIONS**  
**FOR**  
**TANK, FABRIC, COLLAPSIBLE, WATER STORAGE,**  
**20,000 and 50,000 GALLONS**



---

**OPERATOR AND UNIT MAINTENANCE MANUAL  
(INCLUDING REPAIR PARTS AND SPECIAL TOOLS LIST)  
TANK, FABRIC, COLLAPSIBLE, WATER STORAGE,  
20,000 AND 50,000 GALLONS  
DESCRIPTION AND USE OF CONTROLS AND INDICATORS**

---

**GENERAL**

This section lists and describes the function of major components, controls, and indicators of the collapsible fabric water tank assemblies.

**DESCRIPTION AND USE OF MAJOR COMPONENTS**

Description and use of major components, including controls and indicators are contained in Table 1.

**Table 1. Major Components, Controls and Indicators.**

Key	Component, Control, or Indicator	Function
1	Filler/Discharge Assemblies	Provides the means to both fill and remove water from the tank. Allows a hose assembly to be connected to the tank. Directs the flow of water through the hose assembly into the tank when filling, and out of the tank when discharging. Can be accessed by removing the dust cap. Located in two places on top of the tank at diametrically opposite ends.
2	Vent Fitting Assembly	Contains a mushroom type vent cap that is calibrated to open when the tank is subjected to an internal vapor pressure greater than 3 inches (7.62 cm) of water. Vent cap is connected at the top of the vent pipe. Located in middle of the tank.
3	Drain Fitting Assemblies	Allows the drain hose assembly to be connected directly to the tank. A drain fitting assembly is mounted on the underside of the tank at each end of the tank. When the drain plug is removed, the drain hose assembly can be installed.
4	Drain Hose Assembly	Allows water to drain from the water tank. Hose assembly is comprised of an 8-foot section of hose attached to a hand operated ball valve. The hose is connected to the tank drain fitting during installation.
5	Drain Ball/Gate Valve (2-inch)	Allows water to drain from the collapsible storage tank. The valve is normally closed when the tank is not being drained or replaced.
6	Filler/Discharge Ball/Gate Valve (4-inch)	Allows water to flow to and from the tank assembly. The valve is normally closed when the tank is not being filled or water is not being discharged from the tank.
7	Tank Handles	Provides attachment points used to lift, move or position the empty water tank and the ground cloth, if equipped.
8	Tank (Water)	Collapsible elastomeric-coated fabric water storage tank in 20,000 and 50,000 gallon capacities. Used for storage and containment of potable drinking water.
9	Ground Cloth  Repair Kit (Not Shown)	The ground cloth, if equipped, is spread out to protect the bottom of the tank from abrasion and wear resulting from contact with the ground.  The repair kit contains all items needed to perform temporary repairs of cuts and punctures to the tank fabric.



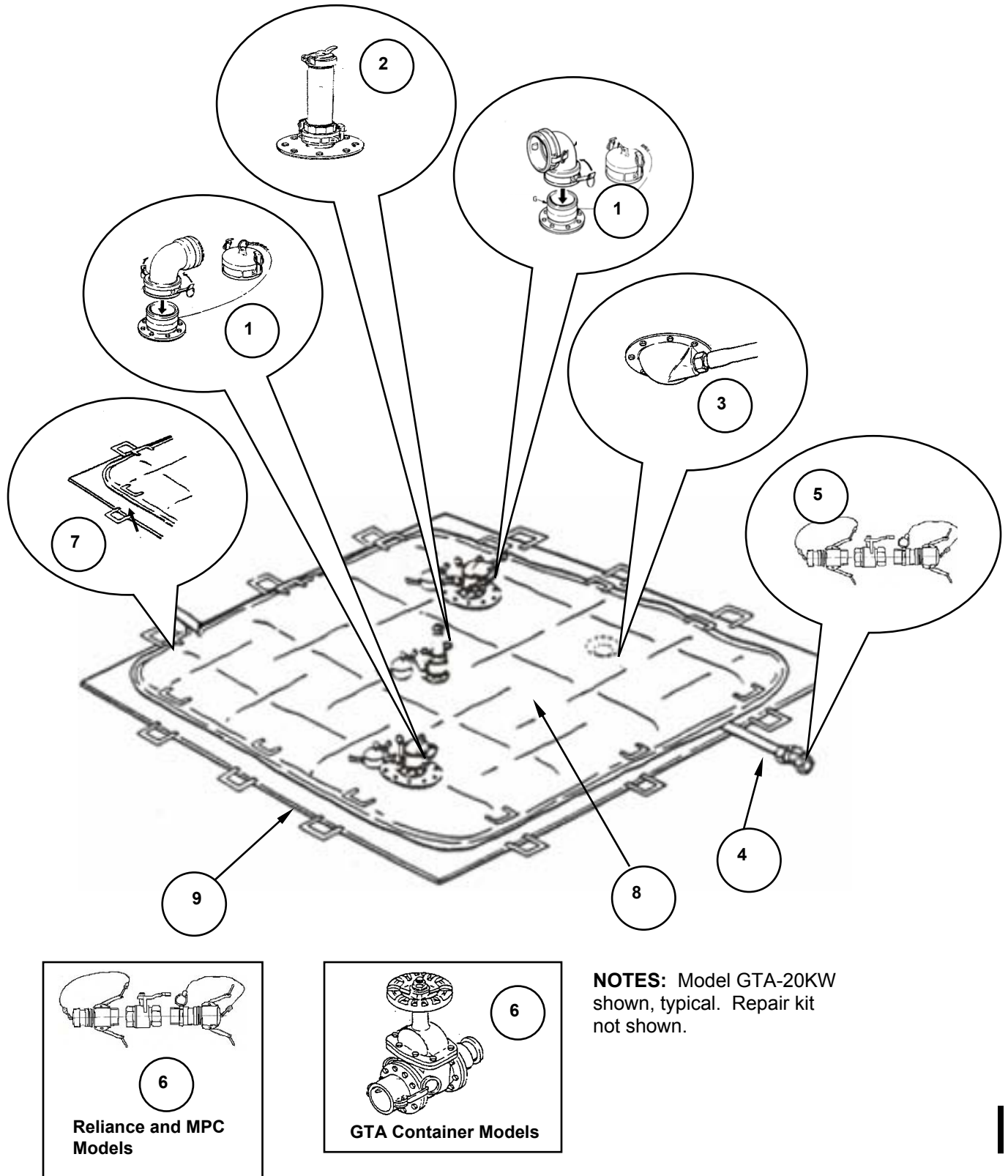

END OF WORK PACKAGE



**OPERATOR AND UNIT MAINTENANCE MANUAL  
(INCLUDING REPAIR PARTS AND SPECIAL TOOLS LIST)  
TANK, FABRIC, COLLAPSIBLE, WATER STORAGE,  
20,000 AND 50,000 GALLONS  
OPERATION UNDER USUAL CONDITIONS**

## SITING REQUIREMENTS

### WARNING

The maximum permissible ground slope is one degree (three inch slope in 100 feet). Turbulence of water in the tank during filling or during high winds may cause the tank to roll and cause serious injury to personnel if placed on sloping ground.

### CAUTION

Clear the area of sticks, stones, heavy vegetation, or any debris that may puncture or damage the tank fabric.

1. Site selection must consider where and in what configuration the water tank will be used within the water distribution system. Select a site in proximity of intended usage approximately 6 feet wider and longer than the flat empty tank size. For best operating condition, the selected site should be level but should never exceed 3 inches slope in 100 ft. If a level site cannot be obtained, the tank may be positioned with the lengthwise axis parallel to the slight slope with drainage in a downhill position. In those instances when the tank is positioned across the slope, it is important that the tank be stabilized against rolling. This can be accomplished by forming an earthen dike on the downhill side, or by means of smooth timbers or sand bags. A level spot or depression may be cut in the hillside to level the tank.
2. Prepare the site for installation. Avoid deep irregularities that will trap liquid. Clear the area of rocks, vegetation, or anything that could puncture or abrade the tank fabric. Fill all holes and depressions. Flatten and smooth ground surface. For the 50K tanks, an area 75 by 35 feet minimum is needed.
3. Select an area that will provide enough clearance to provide for a dike. A dike is used to stop the water flow in the event a rupture occurs. At least a five-foot perimeter around the empty tank is also needed for a service area.
4. If the tank is to be used on the site for a long period, a minimum of 4 inches of sand or soil should be put down before the tank is placed into position.
5. If the site has a slight slope, place the tank drain towards the lowest end. For best operation, the ground slope should be 3 inches in 100 feet, not to exceed one degree.

### NOTE

When filling the tank on sloped ground, do not exceed the specified tank height.

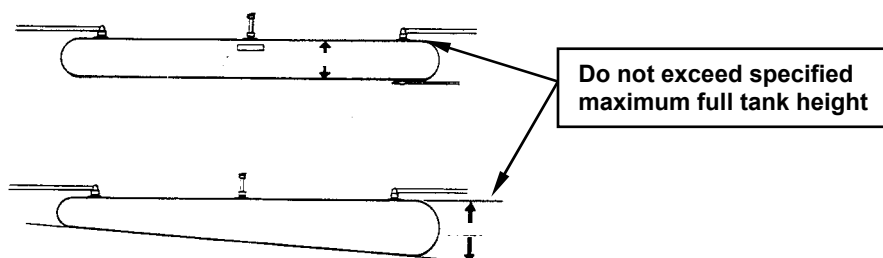

6. Install the ground cloth over the installation site, if equipped and provided prior to receipt of tank.

**UNPACKING THE EQUIPMENT**

1. If the 20K tank is part of a 40K water distribution system, the tank may be packed in a reusable container. Refer to TM 10-4610-234-13 for specific unpacking instructions.
2. If the 20K tank is not part of a 40K water distribution system, position the packaged (unopened) water tank on an approved site near the point of installation. If the water tank is received in a wooden shipping crate, proceed as follows:
  - a. Cut the banding straps from the crate.

**CAUTION**

**Remove all protruding nails and other objects before attempting to remove the tank from the container. This is necessary to avoid puncturing the tank.**

- b. Carefully open the shipping container by removing nails and bolts from the container lid, the retaining boards, container sides, and ends.
- c. Remove tank accessories, drain fitting hoses, filler/discharge hose, and packing list from the area surrounding the tank. Remove all packing material.

**CAUTION**

**When removing a tank from the shipping container, the tank-lifting device must have a minimum capacity of 2500 lb. (1135 kg). This is necessary to avoid damage to equipment and the tank.**

- d. Locate lifting straps around the tank. Insert a lifting bar (2500 lb./1135 kg. minimum capacity) through the loops of the lifting straps. For GTA tank models, lifting straps are pre-attached to the tank.
- e. Use lifting device, lifting bar, and lifting straps to remove tank from crate.
- f. Transport tank to the center of desired installation site. Install ground cloth at site, if equipped.

**NOTE**

If a tank is being replaced, package the unserviceable tank in the empty container in the same manner that the new tank was packaged.

3. Know the contents of the tank shipping container by reviewing the enclosed packing list.

**NOTE**

Items inside the wooden crate are listed sequentially from the top of the crate to the bottom of the crate:

ITEM	QUANTITY
Hoses	Three (3) each
Lifting Straps	Two (2) each
Water Tank	One (1) each
Partition containing accessories, quick disconnect fittings, packing list, and emergency repair items.	One (1) each

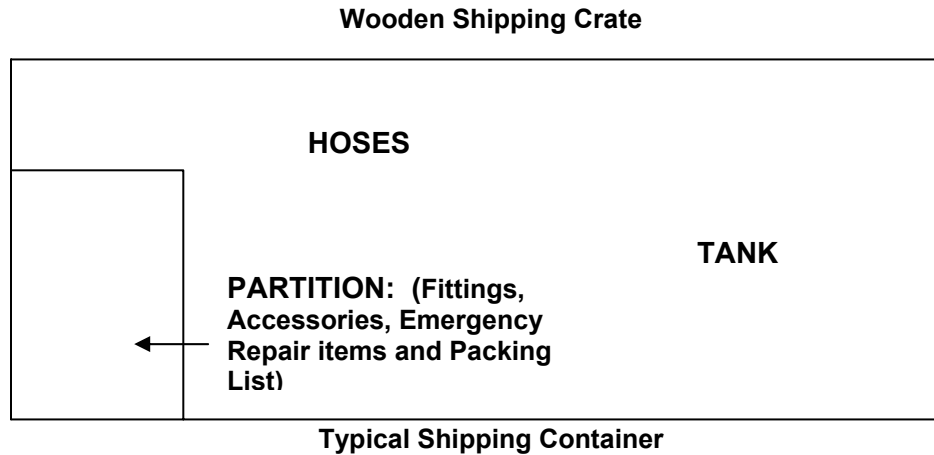

4. Unwrap and inspect the enclosed equipment for damage incurred during shipment.
5. Check the equipment against the packing list to verify completeness. Report all discrepancies in accordance with DA PAM 738-750.
6. Verify that equipment removed from the shipping container has not been modified.
7. Remove all protective compounds such as wax paper, waterproof tape, and barrier material. Remove preservatives and greases from unpainted, threaded, or exposed surfaces.
8. Unpacking the 50K tank:

#### **WARNING**

**A minimum of two personnel is required to unfold and position the ground cloth. Lifting or unfolding heavy equipment without assistance can cause serious injury to personnel and damage to equipment.**

#### **NOTE**

The ground cloth is normally provided in a different type of container than the water tank. This container is not shipped with the water tank.

- a. Remove lag bolts from lid of ground cloth crate. Lift crate lid and remove ground cloth bundle.
- b. Position ground cloth bundle at desired installation site. Remove ties from ground cloth bundle and center the ground cloth over the site. Unfold ground cloth over installation site and smooth out creases and wrinkles.
- c. Place the tank crate near the lower end of the prepared installation site with suitable means, such as a forklift or other lifting device. If the site is sloping, the crate should be placed at the lower end of the slope.
- d. Remove lag bolts and other fasteners from the top and bottom of crate sides.
- e. Lift off crate lid. Remove accessories, lifting straps, repair kit, packing list, etc., and place them on the side.

**CAUTION**

**When removing tank from the shipping container, the tank-lifting device must have a minimum capacity of 2500 lb. (1135 kg). This is necessary to avoid damage to equipment and the tank.**

- f. Locate lifting straps around the tank. Insert a lifting bar (2500 lb./1135 kg. minimum capacity) through the loops of the lifting straps.
- g. Remove water tank from crate using lifting bar, lifting straps, and tank lifting device.
- h. Transport tank to center of ground cloth located above prepared installation site. Place water tank on ground cloth by positioning long side of tank parallel with long side of installation site.
- i. Unfold one-half of tank along the length of the prepared installation site and unfold the other half of the tank in the opposite direction along the width of the installation site.

**NOTE**

Tank repair items (sealing clamps, plugs, gaskets, etc.) are packaged in a sealed container and should be placed in a secure storage area until needed.

- j. Grasp handles along one side of tank and pull the folded sides of the tank towards the side edge of the ground cloth. Repeat on opposite side. Pull all handles repeatedly until tank is completely unfolded.

**CAUTION**

**Do not attach handles to a mechanical pulling device or damage to the tank will occur. Do not walk on the tank unless necessary. If necessary, walk on tank wearing soft soled shoes wiped clean of all abrasive materials.**

- k. Move the tank into its final position using the handles.
- l. Smooth out all wrinkles and creases in the tank fabric.
- m. Remove vent fitting assembly, filler/discharge gate or ball valve, and two drain ball valves from cushioning bags. Remove cushioning bags from ends of all hoses. Save all cushioning bags and packing material to reuse when the tank is put back into storage.

**ASSEMBLY AND PREPARATION FOR USE****Drain Assembly**

1. Fold back tank to expose the drain assembly. Dig a shallow trench in the ground from the drain assembly to the outer edge of the tank to house the drain assembly and drain hose. If the tank is positioned on hard ground, make a bed of sand or soft soil to support the drain assembly and hose. This will alleviate stress on the fabric when the tank is filled with water. Trench must allow free drainage when tank is emptied and folded for repacking.
2. Remove the drain plug.

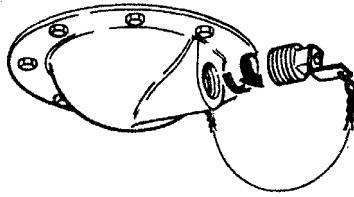

3. Install the drain hose to the drain assembly.

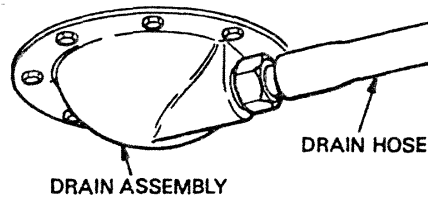

4. Place the drain hose into the prepared trench and return the tank to its normal flat position.
5. Make sure drain gate valve or lever is closed.

**Filler/Discharge Assembly (Female/Male Elbow)**

1. Remove the dust cap from the discharge coupling (above the drain assembly).

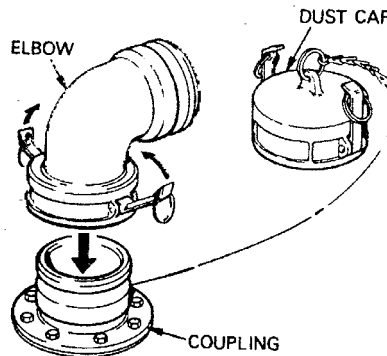

2. Put the female/male elbow onto the coupling. Clamp into position using the cam lock arms and pointing the male part of the coupling in the direction the discharge hose will lie.

**Filler/Discharge Assembly (Female/Female Elbow Fitting)**

1. Remove the dust cap.

**WARNING**

**Ensure the elbow is correctly attached to the coupling assembly and the filler hose. If improperly installed, pressure buildup during filling could cause the fittings to fly apart and cause injury.**

2. Install the female/female elbow onto the coupling assembly. Position it in the direction the filler hose will lie and clamp using the cam lock arms.

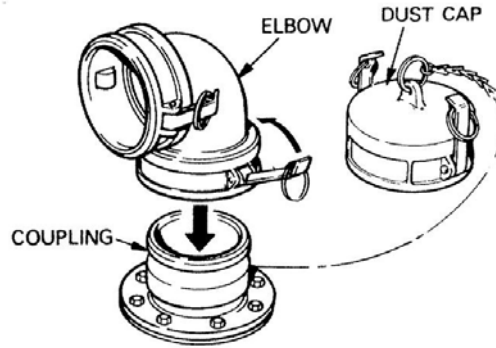

### Vent Fitting Assembly

1. Remove the dust cap and clamp the coupling half in place.

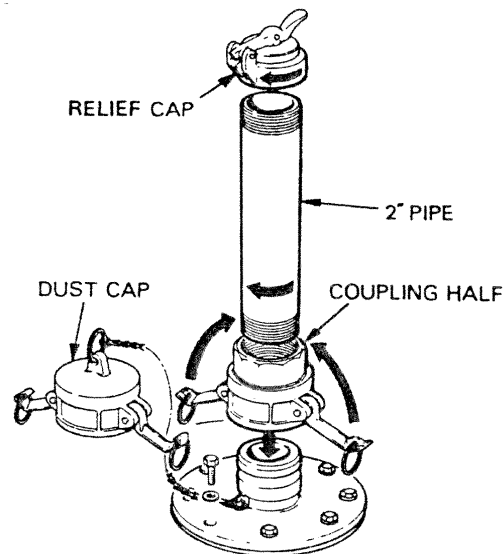

2. Install the vent pipe; hand-tighten only.

### NOTE

Some tank models are equipped with cam lock lever couplings whose design is different from the design of other tank models.

3. Install the mushroom type vent relief cap, hand-tighten only. Make sure the flap moves freely. The flap must be in the closed position.

### OPERATING PROCEDURES

Only two operator controls are utilized on the water tanks. They are the gate or ball valve to control the water flow during fill/discharge and the drain ball valve to control draining.



## Filling The Tank

### CAUTIONS

**Do not allow the filler/discharge hoses to strain tank fabric during operation. If necessary, support each hose to prevent stress on the tank fabric, which could cause damage to the hose.**

**Personnel assigned to operate the water tank must periodically check the dates on the data plates to verify that the tank is safe for use. Each tank has a one-year service life beginning on the date when it is first filled. Shelf storage life is five years from the date of manufacture. Users must initiate action to replace over-aged tanks. Failure to heed this caution can cause tank to rupture.**

### NOTE

Either filler/discharge assembly can be used as the fill or discharge port.

1. After performing adjustments and routine checks, attach the water source to the filler/discharge gate or ball valve. Close the valve on the drain hose assembly. Verify the drain ball or gate valve is closed.
2. Check the vent fitting installation to make sure the mushroom type vent cap is not plugged.
3. Water may be introduced into the tank by several means. Two recommended methods are as follows:
  - a. With the vent pipe assembly in place and vent cap open, water may be introduced into the tank through the filler/discharge ball or gate valve until the fluid reaches the specified height in the tank vent pipe, three inches, but not to exceed the maximum specified filled tank height.
  - b. With the mushroom type vent cap closed, water may be metered into the collapsed tank through the filler/discharge ball or gate valve by means of a gravity head or by pumping.
4. Activate the water source.
5. Open the gate or ball valve and begin filling water tank. Maximum fill rate is 350 gallons (1,325 liters) per minute.
6. Fill the tank with 2,000 gallons. Observe the tank body, fittings, and vent during filling operations to assure they are secure and not leaking. Reseat couplings if they leak. Report all leaks immediately to local supervision. If no leaks are found, fill tank to noted capacity. Do not overfill.
7. Verify the vent fitting assembly vent cap is operating properly and not stuck in a closed position.

## CAUTION

Do not exceed the noted capacity of the tank when filling. If a metering gauge is not available at the time of filling, do not exceed the specified maximum filled tank height. The water tank will burst if it becomes overfilled, causing damage to equipment.

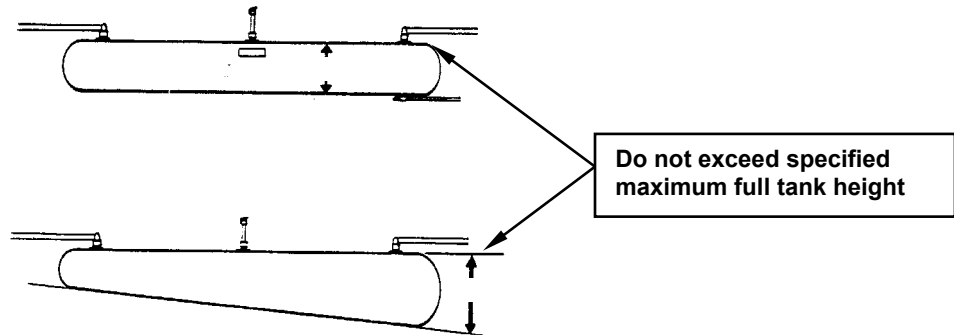

8. Close the gate or ball valve when the tank is full.
9. Deactivate the water source.
10. Disconnect the water source from the gate or ball valve.

### INITIAL ADJUSTMENTS AND ROUTINE CHECKS

1. Check for leaks.
2. If the tank is cut or punctured during any phase of operation, refer to WP 0006 00 for emergency repair procedures.
3. Tighten any loose components. Refer to WP 0008 00 for operator troubleshooting procedures.

### DISCHARGING THE TANK

1. Inspect the water tank to verify that the tank is set up correctly.

#### NOTE

Use the female/male discharge elbow for this operation.

2. Verify the drain ball valve (2) is closed.
3. Verify the vent fitting assembly mushroom type vent cap (1) is not stuck in a closed position.
4. Attach an emptying source (water distribution system discharge water pump) to the gate or ball valve.
5. If the gate valve (3) is installed on the discharge elbow (5), open the gate valve. If a ball valve is installed on the elbow, open the ball valve.

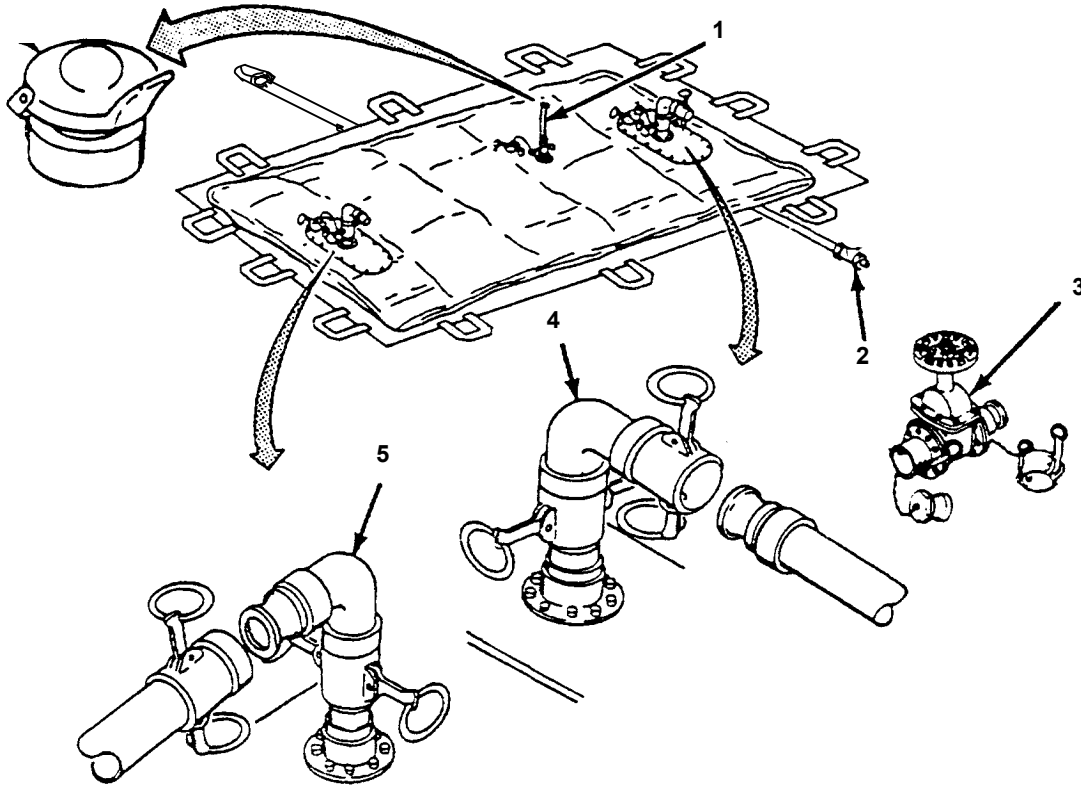

6. If the gate valve (3) is installed on the filler elbow (4), close the gate valve. If a ball valve is installed on the filler elbow, close the ball valve.

7. Open the water system discharge gate valve (3). If a ball valve is installed to control the water system discharge, open the ball valve.

8. Start the water distribution system discharge (suction) water pumps.

9. Allow water to flow from the tank until required amount is discharged.

10. If the gate valve (3) is installed on the discharge elbow (5), close the gate valve (3). If a ball valve is installed on the discharge elbow, close the ball valve.

11. Close the water distribution system discharge (suction) gate or ball valve.

12. Disconnect the filler/discharge hose from the elbow, if attached.

13. Open the drain fitting ball valve to allow the remaining water to drain from the tank.

14. Close the ball valve when the tank is empty by rotating the handle clockwise.

#### **OPERATION OF AUXILIARY EQUIPMENT**

No auxiliary equipment is provided with the collapsible fabric water tank assembly.

## PREPARATION FOR MOVEMENT

### Draining, Disassembly and Exterior Tank Cleaning

1. Relieve any hose pressure.

#### NOTE

Four personnel are required to handle and fold a 20K water tank during draining and disassembly. Five personnel are required to handle the 50K water tank.

2. Open the drain hose assembly ball valve and drain all water from tank.

#### NOTE

Use of the gate or ball valve is optional and only used as required.

3. Pull the cam lock arms out from filler elbow coupling to release and disconnect gate or ball valve. Turn handle to open gate or ball valve and drain. Install the dust cap and plug on gate or ball valve.
4. Remove the filler elbow coupling by opening the cam locks. Install dust cap on tank filler coupling.
5. Disconnect the water suction hose from the discharge elbow.
6. Remove the discharge elbow by opening the cam locks. Install the dust cap on tank discharge coupling.
7. Drain any remaining water from tank by rolling water tank edges towards the center while squeezing water towards drain.
8. Open cam locks and remove the vent fitting assembly.
9. Install the vent fitting assembly dust cap(s).
10. Lift tank end and locate drain fitting.
11. Disconnect the drain hose assembly from the drain fitting.
12. Install the drain plug in the drain fitting after thoroughly drying the tank.
13. Clean the outside surface of the tank with a mild detergent (Item 2, WP 0039 00) and warm water solution and rinse thoroughly with clean water. Allow the exterior of the tank to dry completely.

### Cleaning Tank Interior

1. The tank interior requires little cleaning and should only be cleaned if required.

#### NOTE

If the tank, which requires interior cleaning, is part of a water distribution system, close and disconnect all distribution links.

2. Fill the tank with approximately 150 gallons of detergent (Item 2, WP 0039 00) and water solution.
3. Close off all openings and splash the detergent solution back and forth by alternately pulling the ends of the tank over the top of the tank.

4. Drain the detergent solution from the tank and flush with clean water.
5. Repeat flushing as necessary. Air dry the tank.
6. Clean all components with detergent (Item 2, WP 0039 00) and warm water solution, rinse thoroughly in water, and dry with wiping rags (Item 4, WP 0039 00).

## PACKING AND FOLDING INSTRUCTIONS FOR GTA AND RELIANCE MODEL TANKS

### CAUTION

**Make sure the tank is completely dry before folding. Water will create mildew, decreasing the life of the tank if it is not completely dry.**

### NOTES

- Throughout the folding process, be sure to brush off any stones, grass, or other debris that may accumulate on the tank or the ground cloth.
  - Four personnel are required to handle and fold a 20K water tank during draining and disassembly. Five personnel are required to handle the 50K water tank.
1. Remove the dust cap from the vent fitting assembly or vent pipe.
  2. Empty the tank completely:
    - a. Lay the tank flat.

### CAUTION

**Care should be exercised not to damage the tank by rough handling. If a metal clamp repair has been made, avoid folding the tank in such a manner as to cause damage to the tank.**

- b. Lift up one of the corners of the tank with a "DRAIN FITTING LOCATED UNDER THIS LABEL" decal and flip over to expose drain fitting. There are two drain decals.
    - c. Disconnect drain hose and install drain plug.
    - d. Lay corner back so that tank is flat. Pick up the other corner of tank with a "DRAIN FITTING LOCATED UNDER THIS LABEL" decal to uncover the second drain fitting. Repeat step 2c.
3. Remove vent fitting assembly:
  - a. Locate vent fitting assembly in center top of tank. Remove upper portion of vent fitting assembly by releasing quick-disconnect.
  - b. Wrap upper portion with cushioning material, secure with pressure-sensitive tape (Item 8, WP 0039 00).
  - c. Secure dust cap on vent fitting assembly.
  - d. Apply cushioning material to vent fitting assembly and secure with pressure-sensitive tape (Item 8, WP 0039 00).

4. Remove air from inside tank and remove filler/discharge assembly elbows:
  - a. Locate filler/discharge assemblies located on top of tank.
  - b. Remove upper portion (4-inch 90° elbow) of each filler/discharge assembly by releasing quick - disconnect.
  - c. Wrap upper portion with cushioning material, secure with pressure-sensitive tape (Item 8, WP 0039 00). Set aside.
  - d. Secure dust cap on the filler/discharge assemblies.
  - e. Wrap permanently attached cushioning material around filler/discharge fitting and secure in place with pressure-sensitive tape (Item 8, WP 0039 00).
  - f. Repeat steps 4.b. through 4.e. for the remaining filler/discharge assembly.
5. Tank is now ready for folding. Stand facing the long side of the tank, with a filler discharge fitting to your left. Tank is folded wig-wag, as follows:



6. 1<sup>st</sup> Fold: Start with the left edge of the tank. Lift up the long side of tank closest to you and fold towards center of tank until filler discharge fitting turns over and 3<sup>rd</sup> seam on bottom of tank is exposed.



- a. 2<sup>nd</sup> Fold: Lifting the same long side edge as in the 1<sup>st</sup> Fold, fold back over the outside edge until the 2<sup>nd</sup> seam on bottom of tank is exposed.



- b. 3<sup>rd</sup> Fold: Lifting the same long side edge as in Folds #1 and #2, fold back towards center of the tank.



- c. Go to the right side of the tank.
- d. 1<sup>st</sup> Fold: Lift right side long edge of tank and fold over the folds made in folds #1 through #3 fold.

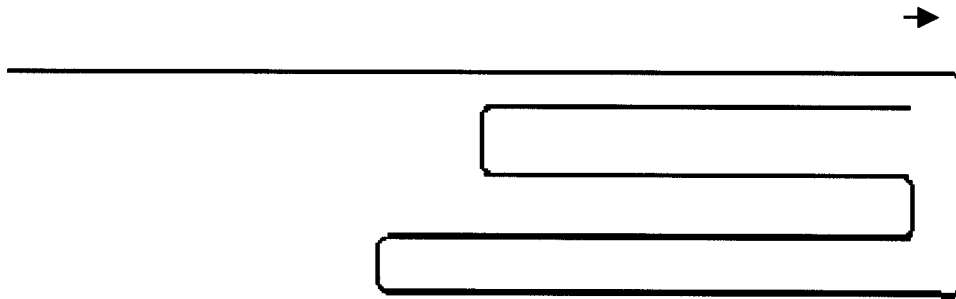

- e. 2nd Fold: Lift up same edge as in Fold #4, and fold back over previous folds. Handles should be facing upward along top edge of fold. (Pulling on these handles will open up the tank, due to the wig-wag method of folding).

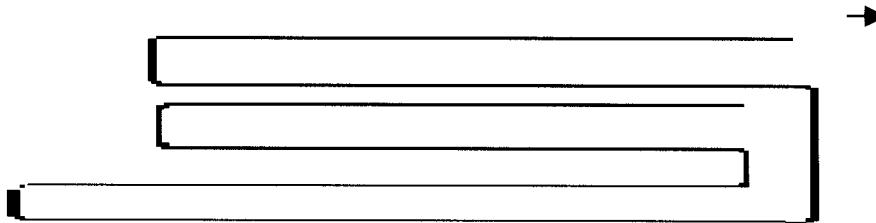

- f. (For 20K Tanks only) Go to the upper edge of the tank. The tank is now folded into a long narrow rectangle approximately 45 inches (114.3 cm) wide. Standing at the upper edge of the tank, there will be a drain fitting on your left and handles on your right.
- g. (For 20K and 50K Tank) Go to the upper edge of the tank. The tank is now folded into a long narrow rectangle approximately 5 feet 6 inches (1.676 m) wide by 65 feet 6 inches (19.96 m) long. Standing at the upper edge of the tank, there will be a drain fitting on your left and handles on your right.
- h. (All tanks) 1<sup>st</sup> Fold: Pick up the end edge of the tank and fold it over to just before the fitting chafing patches, such that the fold measures approximately 4 feet 3 inches (1.295 m).



- i. (20K Tank only) 2<sup>nd</sup> Fold: Fold the entire lower edge of the package up and on top of the upper edge of the package. Go to Step 7.

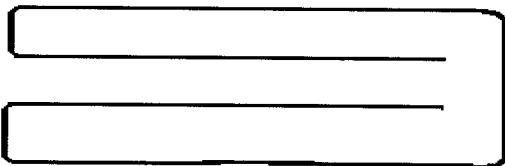

- j. (For 20K and 50K tanks) 2<sup>nd</sup> Fold: Fold the tank over again, such that the second fold reaches the edge of the 3<sup>rd</sup> handle and measures 4 feet 7 inches (1.397 m) approximately.



- k. (For 20K and 50K Tanks) 3<sup>rd</sup> Fold: Fold tank over again, approximately 5 feet (1.524 m).



- l. (Steps m-o for 50 K Tank only) 4<sup>th</sup> Fold: Fold tank over again, approximately 5 feet 1 inches (1.549 m).

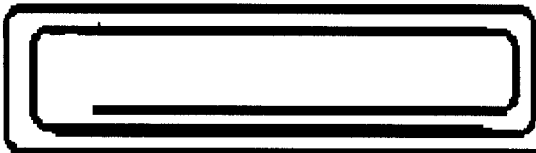

- m. 5<sup>th</sup> Fold: Fold tank over again, approximately 5 feet 2 inches (1.575 m).

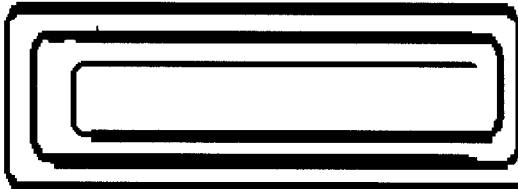

- n. 6<sup>th</sup> Fold: Fold the tank over again, such that the vent fitting is located in the center of the fold. Fold will measure approximately 5 feet 6 inches (1.676 m). Adjust the folded package so that folds line up and package is stacked straight and upright, not twisting.

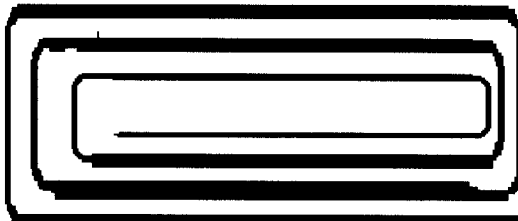

- o. (Steps p-r for 20K and 50K Tanks only) Go to the lower edge of tank.
- p. 1st Fold: Starting at the lower edge of the tank, fold up to the fitting chafing patch, approximately 3 feet 10 inches (1.168 m).





- q. 2nd Fold: Fold to edge of 3rd handle, approximately 4 feet 6 inches (1.372 m).



- r. (For 20K Tank only) 3<sup>rd</sup> Fold: Fold the entire lower edge of the package up and on top of the upper edge of the package. Go to Step 7.

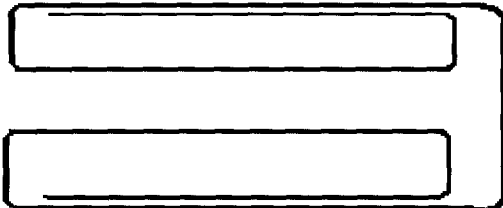

- s. (For 20K and 50K Tanks) 3rd Fold: Fold over again, approximately 4 feet 7 inches (1.397 m).



- t. (For 20K Tank only) 4<sup>th</sup> Fold: Fold the entire lower edge of the package up and on top of the upper edge of the package. Go to Step 7.

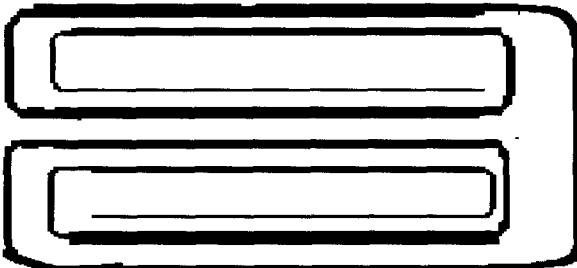

- u. (Steps u-w for 50K Tank only) 4th Fold: Fold again, approximately 4 feet 8 inches (1.422 m).



- v. 5<sup>th</sup> Fold: Fold over again. There should now be an 18-inch (45.72 cm) gap between the folded packages from the upper and lower edges of the tank.

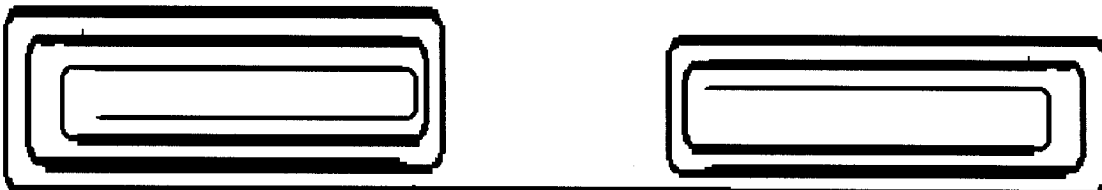

- w. 6<sup>th</sup> Fold: Fold the entire lower edge of the package up and on top of the upper edge of the package. Package measures 4 feet 7 inches in width and 5 feet 4 inches (1.626 m) in length, approximately.

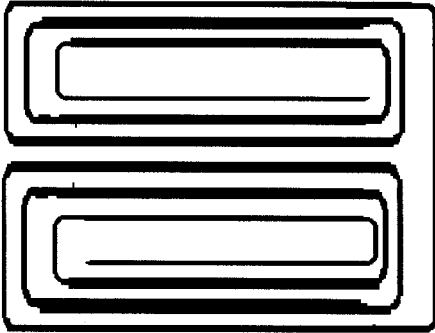

7. Slide lifting straps under tank from either side, adjusting until straps are 18-inches (45.72 cm) from the edges of the tank package.
8. Lift tank from the right edge by looping the lifting straps over lifting bar (if provided) or over lifting device.

## PACKING AND FOLDING INSTRUCTIONS FOR MPC MODEL TANKS

## CAUTION

Make sure the tank is completely dry before folding. Water will create mildew, decreasing the life of the tank if it is not completely dry.

## NOTES

- Throughout the folding process, be sure to brush off any stones, grass, or other debris that may accumulate on the tank or the ground cloth.
- Four personnel are required to handle and fold a 20K water tank during draining and disassembly. Five personnel are required to handle the 50K water tank.

1. Remove dust cap (1) from vent fitting (2) on tank (3).
2. Working from sides of tank (3) tightly fold both sides towards center of tank and stop at vent fitting (2). Brush off any stones, dirt, twigs or debris on tank fabric. Tightly fold both sides towards center of tank (3) again.
3. Roll tank (3) ends toward vent fitting (2).
4. Place two web straps (4) around tank (3).
5. Remove rolled tank (3) from ground cloth (5).

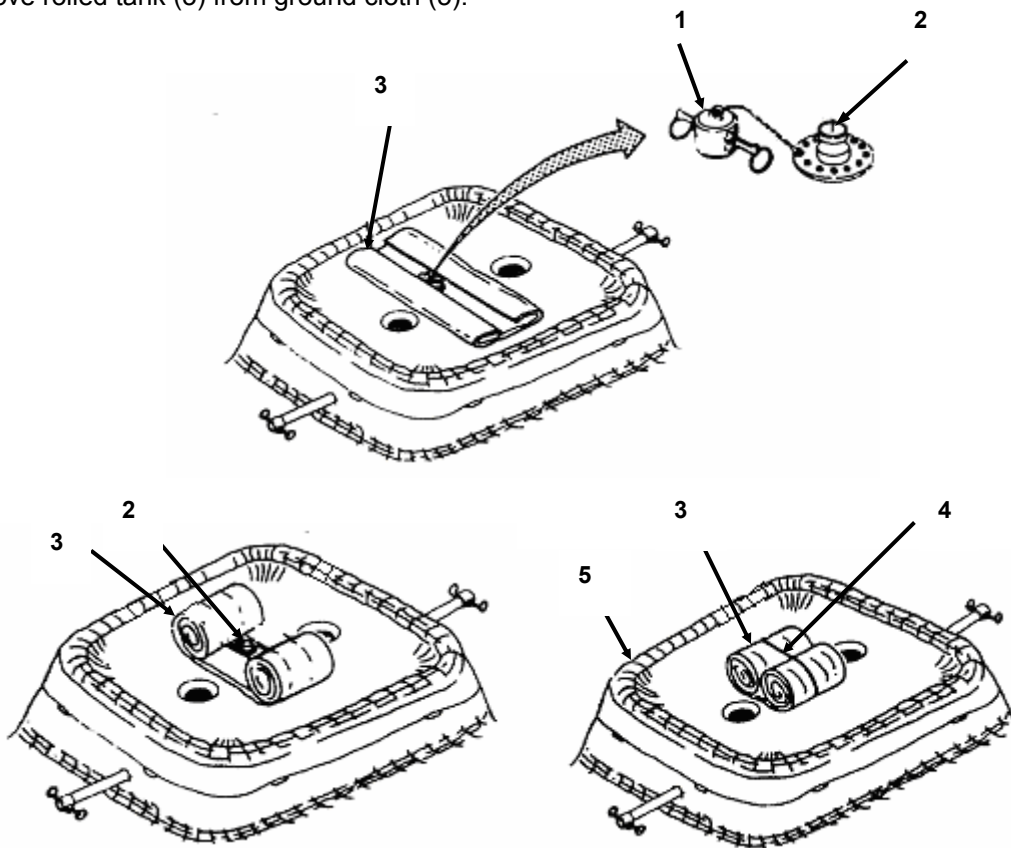

**Packing the Tank In Standardized Containers**

1. Lower folded tank package into shipping container (or wooden crate) from backside of container (or crate) with markings and address label on front side. Tank should be situated in container (or crate) with it flush with the front edge, leaving a 4-inch (10.16 cm) gap in the back (into which hoses will be placed).
2. Install dust cap on vent fitting assembly or vent pipe.
3. Repack and store accessories and auxiliary equipment in shipping container, crate, or box.
4. Fold ground cloth into a bundle and tie. Store ground cloth in alternate storage location.

Refer to Equipment Data (WP 0002 00) for folded dimensions, if desired.

**Packing In A Reusable Container**

If water tank is supplied as part of the 40K water distribution system, refer to TM10-4610-234-13 for instructions on packing the water tank in a reusable container.

**END OF WORK PACKAGE**

---

**OPERATOR AND UNIT MAINTENANCE MANUAL  
(INCLUDING REPAIR PARTS AND SPECIAL TOOLS LIST)  
TANK, FABRIC, COLLAPSIBLE, WATER STORAGE,  
20,000 AND 50,000 GALLONS  
OPERATION UNDER UNUSUAL CONDITIONS**

---

### **OPERATION IN EXTREME HEAT**

Observe the following precautions when operating the water tank in extreme heat:

#### **CAUTION**

**Avoid unnecessary folding, unfolding or rolling of the empty water tank. Cracks can develop in the tank fabric causing damage.**

- a. Protect tank from extreme heat by covering with tarp, setting up in a shaded area, or by constructing a sun block.
- b. Ventilate area around the tank. Airflow should circulate freely around tank.
- c. Do not store in direct sunlight.

### **OPERATION IN EXTREME COLD**

#### **CAUTIONS**

- **If the tank is used in temperatures below freezing [32°F (0°C)], caution must be used to prevent water in the tank or in contact with the fluid discharge fittings from freezing. If water freezes, damage may occur to the tank and/or fittings.**
  - **Avoid any unnecessary folding, unfolding, or rolling of tank in freezing temperatures. Cracks can develop in the tank fabric causing damage.**
1. Do not allow ice to accumulate on the tank or the fill/discharge fittings.
  2. Keep snow and ice clear of the vent assembly.

### **OPERATION IN SALT WATER AREAS**

Salt water causes corrosion. Use fresh, clean water to wash salt deposits off all fittings. Examine fittings for corrosion after washing. Report any corrosion to the immediate supervisor.

### **OPERATION IN DUSTY, SANDY OR SNOWY CONDITIONS**

1. Keep dust caps in place on fittings and couplings until ready to use.
2. Carefully inspect coupling gaskets. Remove all dust, dirt, sand or snow from gaskets before connecting couplings.
3. Wind may blow dust, sand, or snow under one side of the tank, which may cause the tank to roll over.

### **OPERATION AT HIGH ALTITUDES**

No special procedures are required for operation at high altitudes.

## OPERATION IN WINDY CONDITIONS

1. If only partially filled, the tank could roll over in windy conditions.
2. Secure the tank with suitable straps or ropes if high winds are expected.

### CAUTION

**Do not attach the guy ropes to the tank handles.**

3. Pass the restraining straps or ropes under and over the tank and fasten securely to stakes in the ground.

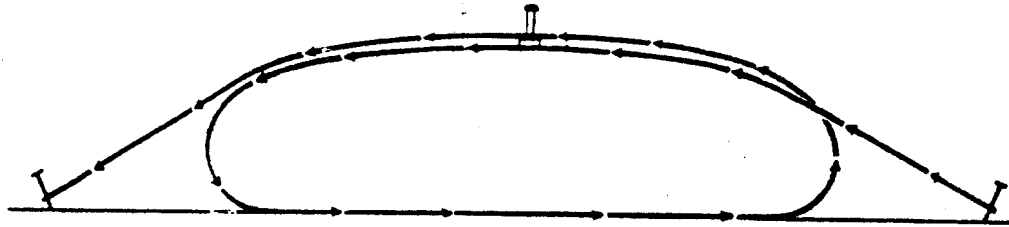

## INTERIM NUCLEAR, BIOLOGICAL AND CHEMICAL (NBC) DECONTAMINATION PROCEDURES

### NOTE

For detailed decontamination procedures, refer to FM 3-3, FM 3-4, and FM 3-5.

### GENERAL

The following emergency procedures can be performed until field NBC decontamination facilities are available.

### NBC EMERGENCY PROCEDURES

### WARNING

**If NBC attack is known or suspected, don mask immediately and continue mission. Mask should not be removed until instructed to do so.**

1. Nuclear decontamination – Brush fallout from skin, clothing, and equipment with available brushes, rags, or tree branches. Wash skin and undergo radiation check as soon as tactical situation permits.
2. Biological decontamination – Remain masked and continue mission until instructed to unmask.

### 3. Chemical detection and decontamination.

#### **WARNING**

**Do not use decontamination spray on personnel. It could cause personal injury.**

- a. Use M8 paper from the M256 chemical agent detector kit or M9 paper to determine if liquid agent is present on the surface of the equipment.
- b. If the M8 or M9 paper indicates that liquid chemical agent is present, rinse the exposed portion of the collapsible tank with a liberal amount of water. When the tactical situation permits, wash the collapsible tank with soapy water and rinse.
- c. If exposure to liquid agent is known or suspected, clean all exposed skin, clothing, and personal gear in that order using M258A1 kit. Use the buddy system. Wash exposed skin and thoroughly decontaminate as soon as tactical situation permits. Decontamination procedures take time based on the tactical situation.

#### **EMERGENCY REPAIR PROCEDURES**

##### **General**

Cuts or tears in the water tank smaller than 6½ inches are repaired with sealing clamps. Small punctures are repaired using the wooden plugs. Damage larger than 6½ inches requires replacement of water tank.

##### **Emergency Repairs Using Wood Plugs**

In emergencies, as an immediate temporary measure, the wood plugs may be used for sealing small holes or punctures. The size of the hole or tear will determine the size of the wood plug to be used.

1. For holes (tears) up to approximately 0.5 inch (1.27 cm) in size, use the 3.0-inch (7.62 cm) long plug.
2. For holes (tears) up to approximately 1.0 inch (2.54 cm) in size, use the 4.50-inch (11.43 cm) long plug.
3. For holes (tears) up to approximately 1.5 inch (3.81 cm) in size, use the 5.25-inch (12.7 cm) long plug.

Select the size of the plug needed to fit (seal) the tank puncture. Wet the plug and insert in the puncture hole. Twist the plug clockwise (to the right) until the leak is either stopped or slowed. Regular follow-up inspection should be made of the wood plugs, possible tightening may be necessary if the leaks continue. Eventually, if a leak is not totally stopped, the use of a small sealing clamp may be necessary.



## Emergency Repairs Using Sealing Clamps

Small slits, tears, or cuts [not to exceed 6 inches (15.24 cm) in length] may be repaired with sealing clamps.

The size of the damaged area (opening) needing repair will govern the size of the clamp needed. Select clamp size as follows:

1. For holes (tears) less than 2 inches (5.08 cm) in length, use the 3-inch (7.62 cm) clamp.
2. For holes (tears) 2 to 4 inches (5.08 to 10.16 cm) in length, use the 5-inch (12.7 cm) clamp.
3. For holes (tears) 4 to 6 inches (10.16 to 15.24 cm) in length, use the 7-1/2-inch (19 cm) clamp.

### CAUTION

**It may be necessary to increase the size of the fabric tear in order to be able to insert the bottom plate clamp through the tear. Use extreme care when enlarging a tear. Tension in the fabric may cause the fabric to tear further.**

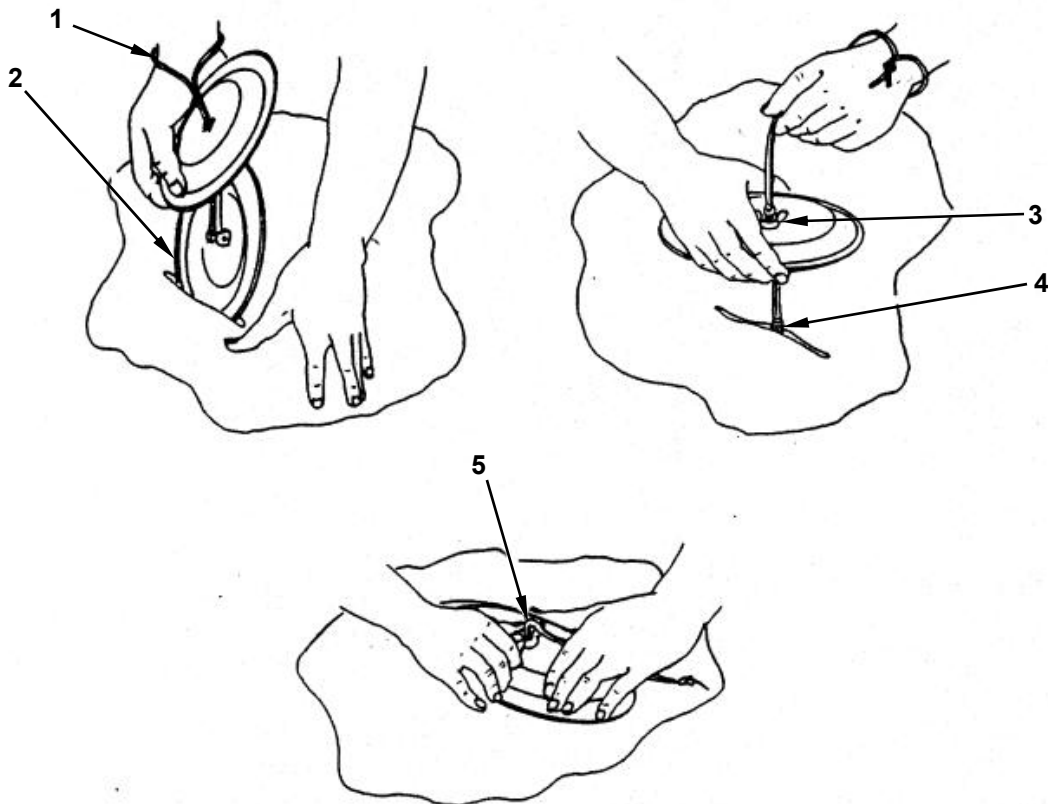

4. Loop cord around wrist (1) to prevent loss of clamp into tank.
5. Slip the bottom plate of the clamp (2) through the hole or tear and rotate it until it is centered and its length runs with the tear.



6. Pull bottom plate up against fabric, and slide top plate (3) and wing nut (5) down cord and onto threaded stud (4) of bottom plate.

### **CAUTION**

**Do not over tighten wing nut. Stud threads may strip or cause damage to tank fabric.**

7. With plates aligned, tighten wing nut (5) clamping the tank wall between the two plates. Tighten wing nut enough to the stop leak.

**END OF WORK PACKAGE**



---

**OPERATOR AND UNIT MAINTENANCE MANUAL  
(INCLUDING REPAIR PARTS AND SPECIAL TOOLS LIST)  
TANK, FABRIC, COLLAPSIBLE, WATER STORAGE,  
20,000 AND 50,000 GALLONS  
DECALS AND INSTRUCTION PLATES**

---

### **DECALS AND DATA PLATES**

Data plates are used on the 20K and 50K water tanks to advise the operator of proper operating procedures. Stencils provide additional operating information and cautions to be observed during use of equipment. The illustration shows examples of typical stencils on the collapsible fabric water tanks.

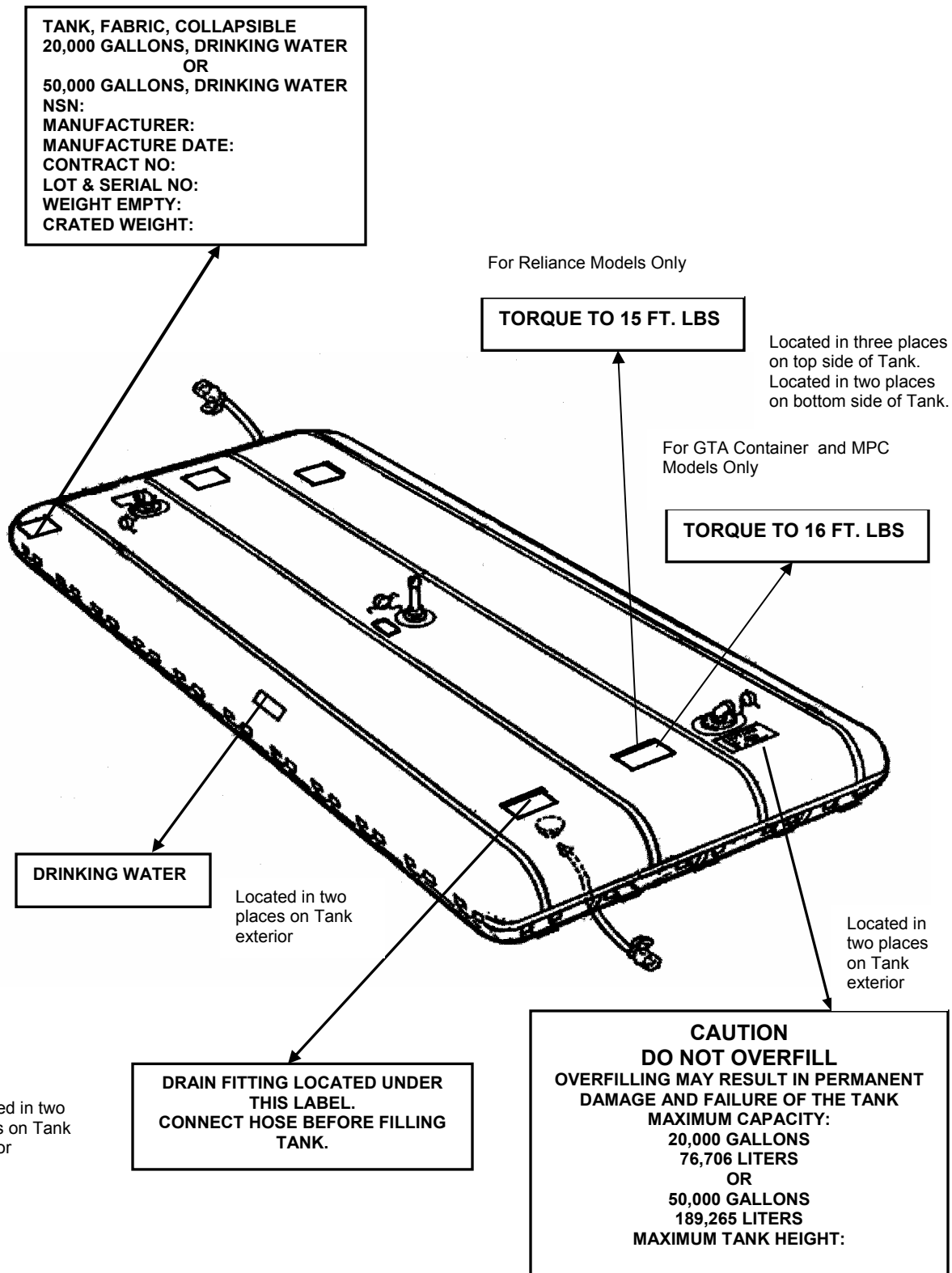

Refer to WP 0002 00 for further examples of stencils on water tank surfaces.

**END OF WORK PACKAGE**

**CHAPTER 3**

**TROUBLESHOOTING PROCEDURES  
FOR  
TANK, FABRIC, COLLAPSIBLE, WATER STORAGE,  
20,000 and 50,000 GALLONS**



---

**OPERATOR AND UNIT MAINTENANCE MANUAL  
(INCLUDING REPAIR PARTS AND SPECIAL TOOLS LIST)  
TANK, FABRIC, COLLAPSIBLE, WATER STORAGE,  
20,000 AND 50,000 GALLONS  
OPERATOR TROUBLESHOOTING PROCEDURES**

---

## **INTRODUCTION TO OPERATOR TROUBLESHOOTING**

The Troubleshooting Procedures section lists the common malfunctions which you may find during the operation or maintenance of the collapsible fabric water tank assembly or its components. Perform the inspections and corrective actions in the order listed in the troubleshooting section.

This manual cannot list all malfunctions that may occur, nor all inspections and corrective actions. If a malfunction is not listed or is not corrected by listed corrective actions, notify your supervisor.

### **WARNING**

**To prevent possible injury, read all warnings in the front of this manual before troubleshooting.**

### **CAUTION**

**To prevent possible flooding, drain the tank partially before attempting to inspect or replace gaskets or seals.**

## **TROUBLESHOOTING PROCEDURE**

### **WATER TANK**

#### **SYMPTOM**

Tank leaks.

#### **MALFUNCTION**

Check tank for cuts, tears, punctures or damaged seams.

#### **CORRECTIVE ACTION**

Perform emergency repairs using wood plugs or sealing clamps. Refer to WP 0006 00. If leak continues, notify unit maintenance.

## **TROUBLESHOOTING PROCEDURE**

### **FILLER/DISCHARGE FITTINGS**

#### **SYMPTOM**

Filler/discharge fittings leak.

#### **MALFUNCTION**

Check filler/discharge fittings for loose, damaged or missing cap screws and gaskets.

**CORRECTIVE ACTION**

If gaskets installed in filler/discharge fittings are damaged, replace gaskets and screws as necessary. See WP 0015 00.

**MALFUNCTION**

Make sure dust plug/cap are securely installed on filler/discharge fittings and that cam-lever coupling arms are secured.

**CORRECTIVE ACTION**

Tighten as necessary or notify unit maintenance for repair.

**TROUBLESHOOTING PROCEDURE****VENT FITTING ASSEMBLY****SYMPTOM**

Vent fitting assembly leaks.

**MALFUNCTION**

Inspect for gasket leakage at cam lock lever coupling and flanged adapter.

**CORRECTIVE ACTION**

Reseal or tighten cam lock lever coupling arms.

Replace cam lock lever coupling dust cap gasket. Refer to WP 0014 00.

Vent fitting assembly continues to leak.

**CORRECTIVE ACTION**

If leak continues, notify Unit Maintenance.

**MALFUNCTION**

Check cam lock lever coupling for cracks or breaks. Check for loose or missing hex-head screws.

**CORRECTIVE ACTION**

If leak continues, notify unit maintenance.

**CAUTION**

**To prevent damage to water tank, the following malfunctions should only be performed when tank is empty.**

**MALFUNCTION**

Check for dirt, bits of gravel and debris on vent relief cap seal.



**CORRECTIVE ACTION**

Lift vent relief cap and clean mating surfaces on cap and seal.

**MALFUNCTION**

Check for bent or broken vent cap pivot pin.

**CORRECTIVE ACTION**

If pin is damaged, notify unit maintenance.

**TROUBLESHOOTING PROCEDURE****TANK DRAIN FITTING ASSEMBLY****SYMPTOM**

Drain fitting assembly leaks between drain ball valve and drain hose fitting.

**MALFUNCTION**

Check to see if the drain hose ball valve is closed.

**CORRECTIVE ACTION**

Close ball valve.

**MALFUNCTION**

Inspect for leakage at drain ball valve stem.

**CORRECTIVE ACTION**

If leak continues, notify Unit Maintenance.

**MALFUNCTION**

Inspect for dirt, bits of gravel, or debris around sealing surfaces.

**CORRECTIVE ACTION**

Clean off dirt, gravel or debris. If leak continues, notify Unit Maintenance.

**SYMPTOM**

Drain fitting assembly leaks between the drain hose fitting and the tank fitting.

**MALFUNCTION**

Check for missing or loose washers and hex-head cap screws.

**CORRECTIVE ACTION**

If hardware is missing or loose, notify Unit Maintenance.

For GTA and Reliance Models, check the preformed packing between the drain cover plate and the tank fitting for nicks, breaks, and compression.

**CORRECTIVE ACTION**

If damaged, notify Unit Maintenance.

Check the drain cover plate for damage or cracks.

**CORRECTIVE ACTION**

If damaged, notify Unit Maintenance.

**TROUBLESHOOTING PROCEDURE**

**TANK DRAIN HOSE ASSEMBLY**

**SYMPTOM**

Drain hose assembly leaks.

**MALFUNCTION**

Check for leaks or breaks in the drain hose.

**CORRECTIVE ACTION**

If hose is damaged, notify Unit Maintenance.

**MALFUNCTION**

Inspect couplings on drain hose assembly for dirt, damage, or wear.

**CORRECTIVE ACTION**

Remove any dirt or foreign objects inside couplings. If leak continues, notify unit maintenance.

**TROUBLESHOOTING PROCEDURE**

**FILLER/DISCHARGE GATE VALVE ASSEMBLY (GTA CONTAINER MODELS)**

**SYMPTOM**

Female quick-disconnect coupling or male flanged adapter leaks.

**MALFUNCTION**

Check the female quick-disconnect coupling for missing or loose hex-head cap screws, hex nuts, washers, and lockwashers. Check for damaged or missing coupling gasket.

**CORRECTIVE ACTION**

If hardware is loose or missing, notify Unit Maintenance.

If female quick-disconnect coupling gasket is damaged or missing, replace gasket. Refer to WP 0012 00.

**MALFUNCTION**

Inspect the flange gasket for damage or leaks.

**CORRECTIVE ACTION**

If damaged, notify Unit Maintenance.

Inspect the male flanged adapter for missing or loose hex-head cap screws, hex nuts, washers, and lockwashers.

**CORRECTIVE ACTION**

If damaged or loose hardware, notify Unit Maintenance.

Male flanged adapter gasket leaks between gasket and valve.

**CORRECTIVE ACTION**

If leaking, notify Unit Maintenance.

**TROUBLESHOOTING PROCEDURE****FILLER/DISCHARGE BALL VALVE ASSEMBLY (RELIANCE AND MPC MODELS)****SYMPTOM**

Ball valve assembly leaks.

**MALFUNCTION**

Check that the ball valve is closed completely.

**CORRECTIVE ACTION**

Close ball valve and tighten securely.

If coupling gasket is damaged or missing, replace gasket. See WP 0013 00.

Inspect the ball valve for damage or wear.

**CORRECTIVE ACTION**

If damaged or worn, notify Unit Maintenance.

Inspect the ball valve for proper alignment.

**CORRECTIVE ACTION**

Align ball valve. If still leaking, notify Unit Maintenance.

**TROUBLESHOOTING PROCEDURE****TANK DRAIN BALL VALVE****SYMPTOM**

Drain ball valve leaks.

**MALFUNCTION**

Check that the drain ball valve is closed completely.

**CORRECTIVE ACTION**

Close ball valve and tighten securely.

Inspect the drain ball valve for damage or wear.

**CORRECTIVE ACTION**

If damaged or worn, notify Unit Maintenance.

Inspect the drain ball valve for proper alignment.

**CORRECTIVE ACTION**

Align drain ball valve. If leak continues, notify Unit Maintenance.

**TROUBLESHOOTING PROCEDURE****FILLER/DISCHARGE HOSE ASSEMBLY****SYMPTOM**

Hose or couplings leak.

**MALFUNCTION**

Inspect for tears and breaks in the hose.

**CORRECTIVE ACTION**

If filler/discharge hose assembly is damaged or leaking, notify Unit Maintenance.

Inspect the quick-disconnect coupling gasket for damage or wear.

**CORRECTIVE ACTION**

Replace the coupling gasket. Refer to WP 0012 00.

Inspect the quick-disconnect coupling for dirt, damage, or wear.

#### **CORRECTIVE ACTION**

Remove the dirt or debris from inside the quick-disconnect coupling. Replace the hose assembly if the corrective action fails to stop the leakage. Notify Unit Maintenance.

### **TROUBLESHOOTING PROCEDURE**

#### **FILLER/DISCHARGE ASSEMBLY**

#### **SYMPTOM**

Filler/discharge assembly leaks.

#### **MALFUNCTION**

Inspect the gasket located between the quick-disconnect coupling and the flanged adapter.

#### **CORRECTIVE ACTION**

Replace the gasket located between the quick-disconnect coupling and the flanged adapter. Refer to WP 0015 00.

Filler/discharge assembly continues to leak.

#### **CORRECTIVE ACTION**

If still leaking, notify Unit Maintenance.

### **TROUBLESHOOTING PROCEDURE**

#### **EMERGENCY REPAIR ITEMS AND SPARE PARTS**

#### **SYMPTOM**

Inspect contents of emergency repair items and spare parts.

#### **MALFUNCTION**

Emergency repair items or spare parts are missing from the fuel tank crate.

#### **CORRECTIVE ACTION**

Replace missing emergency repair item(s) or spare parts.

### **END OF WORK PACKAGE**



---

**OPERATOR AND UNIT MAINTENANCE MANUAL  
(INCLUDING REPAIR PARTS AND SPECIAL TOOLS LIST)  
TANK, FABRIC, COLLAPSIBLE, WATER STORAGE,  
20,000 AND 50,000 GALLONS  
UNIT TROUBLESHOOTING PROCEDURES**

---

## **INTRODUCTION TO UNIT TROUBLESHOOTING**

The Troubleshooting Procedures section lists the common malfunctions which you may find during the operation or maintenance of the collapsible fabric water tank assembly or its components. Perform the inspections and corrective actions in the order listed in the troubleshooting section.

This manual cannot list all malfunctions that may occur, nor all inspections and corrective actions. If a malfunction is not listed or is not corrected by listed corrective actions, notify supervision.

### **WARNING**

**To prevent possible injury, read all warnings in the front of this manual before troubleshooting.**

### **CAUTION**

**To prevent possible flooding, drain the tank partially before attempting to inspect or replace gaskets or seals.**

## **TROUBLESHOOTING PROCEDURE**

### **WATER TANK**

#### **SYMPTOM**

Tank body leaks.

#### **MALFUNCTION**

Check tank for cuts, tears, punctures or damaged seams.

#### **CORRECTIVE ACTION**

Perform emergency repairs using wood plugs or sealing clamps. Refer to WP 0006 00. If leak cannot be repaired, immediately notify supervision.

## **TROUBLESHOOTING PROCEDURE**

### **VENT FITTING ASSEMBLY**

#### **SYMPTOM**

Vent fitting assembly leaks.

#### **MALFUNCTION**

Inspect for gasket leakage between the quick-disconnect coupling and flanged adapter.

**CORRECTIVE ACTION**

Replace the coupling gasket.

**MALFUNCTION**

Inspect for cracked, broken, or damaged flanged adapter.

**CORRECTIVE ACTION**

Replace cracked or broken flanged adapter. See WP 0025 00.

**MALFUNCTION**

Inspect the vent fitting assembly for loose or missing cap screws and washers.

**CORRECTIVE ACTION**

Replace missing screws and washers. For Reliance Models, torque the fastening hardware to 15.0 ft-lb (20.34 N•m). For GTA Container and MPC Models, torque the fastening hardware to 16.0 ft-lb (21.7 N•m). Refer to WP 0025 00.

**SYMPTOM**

Vent pipe assembly leaks.

**MALFUNCTION**

Inspect the vent pipe gasket for cracks, distortion or wear.

**CORRECTIVE ACTION**

Replace the vent pipe gasket.

**MALFUNCTION**

Inspect the vent pipe for cracks, damage, or distortion.

**CORRECTIVE ACTION**

Replace the cracked, broken or damaged vent pipe. See WP 0025 00.

**TROUBLESHOOTING PROCEDURE****FILLER/DISCHARGE GATE VALVE ASSEMBLY (GTA CONTAINER MODELS)****SYMPTOM**

Quick-disconnect female coupling leaks.

**MALFUNCTION**

Inspect the female quick-disconnect coupling for missing or loose hex-head cap screws, hex nuts, washers, and lockwashers.



**CORRECTIVE ACTION**

Replace missing screws, nuts, washers, and lock-washers. Torque the fastening hardware to 30 in-lb (3.41 N•m). Refer to WP 0021 00.

**MALFUNCTION**

Inspect the female quick-disconnect coupling and flange gaskets for damage or breaks.

**CORRECTIVE ACTION**

Remove the quick-disconnect female coupling and replace the damaged gaskets. Reinstall the female coupling. Refer to WP 0021 00.

**SYMPTOM**

Quick-disconnect male flanged adapter leaks.

**MALFUNCTION**

Inspect the quick-disconnect male flanged adapter for missing or loose hex-head cap screws, hex nuts, washers, and lockwashers.

**CORRECTIVE ACTION**

Replace missing screws, nuts, washers, and lockwashers. Torque the fastening hardware to 30 in-lb (3.41 N•m). See WP 0021 00.

**MALFUNCTION**

Inspect the flanged gasket for damage or breaks.

**CORRECTIVE ACTION**

Remove the quick-disconnect male flanged adapter and replace the flanged gasket. Reinstall the male quick-disconnect flanged adapter. See WP 0021 00.

**SYMPTOM**

Gate valve leaks.

**MALFUNCTION**

Inspect for loose or missing hex-head cap screws and lockwashers on valve body bonnet assembly.

**CORRECTIVE ACTION**

Replace missing hex head cap screws and lockwashers. Torque the fastening hardware to 30 in-lb (3.41 N•m). See WP 0021 00.

**MALFUNCTION**

Check for damaged or distorted gasket located between valve body and bonnet.

**CORRECTIVE ACTION**

Replace the bonnet gasket. See WP 0021 00.

**MALFUNCTION**

Inspect for bent or distorted gate valve stem.

**CORRECTIVE ACTION**

Replace the valve stem. Torque hex head cap screws, new lockwashers, and hex nuts assembled to valve body to 30 in-lb (3.41 N•m). See WP 0021 00.

**TROUBLESHOOTING PROCEDURE****I FILLER/DISCHARGE BALL VALVE ASSEMBLY (RELIANCE AND MPC MODELS)****SYMPTOM**

Quick-disconnect female coupling leaks.

**MALFUNCTION**

Inspect the female quick-disconnect coupling for cracks and damaged or missing cam-locking arms.

**CORRECTIVE ACTION**

Replace quick-disconnect female coupling if cam-locking arms are damaged or missing. See WP 0022 00.

**MALFUNCTION**

Inspect the female quick-disconnect coupling for damaged or missing gasket.

**CORRECTIVE ACTION**

Replace the damaged or missing gasket. See WP 0022 00.

**SYMPTOM**

Quick-disconnect male coupling leaks.

**MALFUNCTION**

Inspect the quick-disconnect male coupling for cracks, dents, or wear.

**CORRECTIVE ACTION**

Replace quick-disconnect male coupling if damaged or worn. See WP 0022 00.

**SYMPTOM**

Ball valve leaks.

**MALFUNCTION**

Inspect ball valve for cracks in housing and signs of leakage around handle area.

**CORRECTIVE ACTION**

Replace ball valve if damaged or if handle area is leaking. See WP 0022 00.

**TROUBLESHOOTING PROCEDURE**

## FILLER/DISCHARGE HOSE ASSEMBLY

**SYMPTOM**

Hose couplings leak.

**MALFUNCTION**

Inspect hose for tears, breaks, and leaks.

**CORRECTIVE ACTION**

If hose is damaged, see WP 0023 00.

**TROUBLESHOOTING PROCEDURE**

## DRAIN HOSE ASSEMBLY

**SYMPTOM**

Drain hose assembly does not drain properly.

**MALFUNCTION**

Inspect drain hose assembly for dirt, grime, cracks or wear.

**CORRECTIVE ACTION**

Service the drain hose assembly. See WP 0024 00.

**TROUBLESHOOTING PROCEDURE**

## FILLER/DISCHARGE ASSEMBLY

**SYMPTOM**

Filler/discharge assembly leaks between the closure plate and the tank fitting.

**MALFUNCTION**

Inspect for missing or loose hex-head cap screws and washers.

**CORRECTIVE ACTION**

Replace missing hex-head cap screws and washers. For GTA Container and MPC Models, torque cap screws to 16 ft-lb (21.7 N•m). For Reliance Models, torque cap screws to 15.0 ft-lb (20.34 N•m). See WP 0026 00 for GTA Models or WP 0027 00 for Reliance Models.

**MALFUNCTION**

Inspect the preformed packing between the closure plate and tank fitting for nicks, breaks, and noticeable compression.

**CORRECTIVE ACTION**

Replace the preformed packing. See WP 0026 00 for GTA Container Models or WP 0027 00 for Reliance Models.

**SYMPTOM**

Filler/discharge assembly leaks between the closure plate and flanged adapter.

**MALFUNCTION**

Inspect for loose or missing nuts, lockwashers, threaded seal washers, and hex-head cap screws.

**CORRECTIVE ACTION**

Replace missing nuts, lockwashers, threaded seal washers, and hex-head cap screws. For GTA Container and MPC Models, torque fastening hardware to 16 ft-lb (21.7 N•m). For Reliance Models, torque fastening hardware to 15.0 ft-lb (20.34 N•m). See WP 0026 00 for GTA Container Models or WP 0027 00 for Reliance Models.

**MALFUNCTION**

Inspect the flanged adapter gasket for damage or wear.

**CORRECTIVE ACTION**

Remove the flanged adapter from the closure plate and replace the damaged flanged adapter gasket. Refer to WP 0026 00 for GTA Container Models or WP 0027 00 for Reliance and MPC Models.

**SYMPTOM**

Filler/discharge assembly leaks through hardware or will not assemble.

**MALFUNCTION**

Check all filler/discharge fastening hardware for cracks, damages, and wear.

**CORRECTIVE ACTION**

Replace the fastening hardware as required. For GTA Container and MPC Models, torque fastening hardware to 16 ft-lb (21.7 N•m). For Reliance Models, torque fastening hardware to 15.0 ft-lb (20.34 N•m). See WP 0026 00 or WP 0027 00.

**SYMPTOM**

Filler/discharge assembly elbows leak.

**MALFUNCTION**

Inspect elbows for cracks, dents, or wear. Check for damaged or missing elbow gaskets.

**CORRECTIVE ACTION**

Replace damaged elbows and gaskets. See WP 0026 00 or WP 0027 00.

**TROUBLESHOOTING PROCEDURE****DRAIN FITTING ASSEMBLY****SYMPTOM**

Drain fitting assembly leaks between drain fitting and tank.

**MALFUNCTION**

Inspect for missing or loose hex head cap screws and washers, GTA Container and Reliance Models only.

**CORRECTIVE ACTION**

Replace missing cap screws or washers. For GTA Container and MPC Models, torque fastening hardware to 16 ft-lb (21.7 N•m). For Reliance Models, torque fastening hardware to 15.0 ft-lb (20.34 N•m). See WP 0028 00.

**MALFUNCTION**

Inspect the preformed packing between the drain cover plate and the tank fitting for nicks, breaks, and noticeable compression, for GTA Container and Reliance Models only.

**CORRECTIVE ACTION**

Replace the preformed packing. See WP 0028 00.

**SYMPTOM**

Drain fitting leaks through metal.

**MALFUNCTION**

Inspect the drain cover plate for damage or cracks.

**CORRECTIVE ACTION**

Replace the drain cover plate. See WP 0028 00.

**TROUBLESHOOTING PROCEDURE****FILLER/DISCHARGE FITTINGS****SYMPTOM**

Filler/discharge fittings leak.

**MALFUNCTION**

Check filler/discharge fittings for loose, damaged or missing cap screws.

**CORRECTIVE ACTION**

Make sure dust plug and cap are securely installed on filler/discharge fittings and that cam-lever coupling arms are secured. Repair as necessary or replace damaged or missing parts. For GTA Container Models, refer to WP 0026 00 and for Reliance and MPC Models, refer to WP 0027 00.

**END OF WORK PACKAGE**

**CHAPTER 4**

**OPERATOR MAINTENANCE INSTRUCTIONS**  
**FOR**  
**TANK, FABRIC, COLLAPSIBLE, WATER STORAGE,**  
**20,000 and 50,000 GALLONS**





---

**OPERATOR AND UNIT MAINTENANCE MANUAL  
(INCLUDING REPAIR PARTS AND SPECIAL TOOLS LIST)  
TANK, FABRIC, COLLAPSIBLE, WATER STORAGE,  
20,000 AND 50,000 GALLONS  
OPERATOR PMCS PROCEDURES**

---

## INTRODUCTION

### General

Preventive Maintenance Checks and Services (PMCS) are performed to keep the collapsible fabric water tank assembly in operating condition. The checks are used to find, correct or report problems. Perform PMCS each time the tank assembly is serviced. Using the PCMS table, always do PMCS in the same order so that it gets to be a habit. With practice, problems can easily be detected. Pay careful attention to WARNING and CAUTION statements. A WARNING means someone could be hurt. A CAUTION means equipment could be damaged.

Before using the tank assembly, do "Before" PMCS.

During tank assembly use, do "During" PMCS.

After the tank assembly is used, do "After" PMCS.

Do "Weekly" PMCS once a week.

Do "Semi-annually" PMCS once every six months.

If something is found to be wrong when performing PMCS, fix it if possible, using troubleshooting procedures and/or maintenance procedures.

Use DA Form 2404 (Equipment Inspection and Maintenance Worksheet) to record any faults discovered before, during, or after operation, unless the faults can be fixed. It is not required to record faults that you can fix. For further information on how to use DA Form 2404, see DA PAM 738-750.

If tools that are required to perform PMCS are not listed in Table 2, WP 0033 00, of the Maintenance Allocation Chart, notify Unit Maintenance.

### PMCS Procedures

Your Preventive Maintenance Checks and Services, Table 1, lists the inspections and care required to keep the water tank assembly in good operating condition.

The "Interval" column of Table 1 indicates when to perform a certain check or service.

The "Procedure" column of Table 1 tells you how to perform the required checks and services. Carefully follow these instructions. When the procedure tells you to, notify your supervisor.

The "Equipment Not Ready/Available If" column of Table 1 explains when and why the equipment cannot be used.

## PMCS Leakage Definitions

It is necessary to know how fluid leakage affects the status of the collapsible fabric water tank. The following noted items are types/classes of leakage needed to be able to determine the status of the collapsible fabric water tank. Learn these leakage definitions and remember – when in doubt, notify supervision.

### CAUTION

**Report Class III and IV leaks to the Supervisor or to Unit Maintenance.  
Failure to heed this caution can cause damage to equipment.**

### NOTES

- Equipment operation is allowed with minor leakages (Class I or II). Consideration must be given to fluid capacity in the item/system being checked/inspected.
- When operating with Class I or II leaks, continue to check fluid levels as required in PMCS.

Class I	Seepage of water (as indicated by wetness or discoloration) not great enough to form drops.
Class II	Leaks of water great enough to form drops but not enough to cause the drops to drip or run from the faulty area.
Class III	Leaks of water great enough to form drops that fall, run, or collect in puddles near the faulty area.
Class IV	Leaks found under the tank. There is evidence of dampness on the ground around the tank. Volume of water in tank is less than it should be.

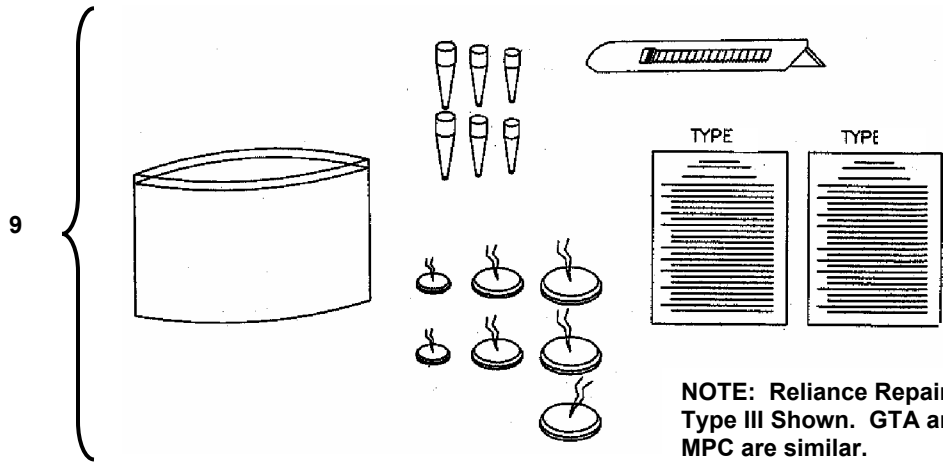
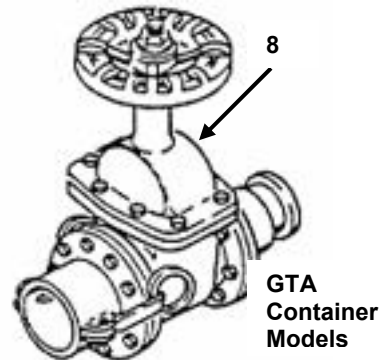
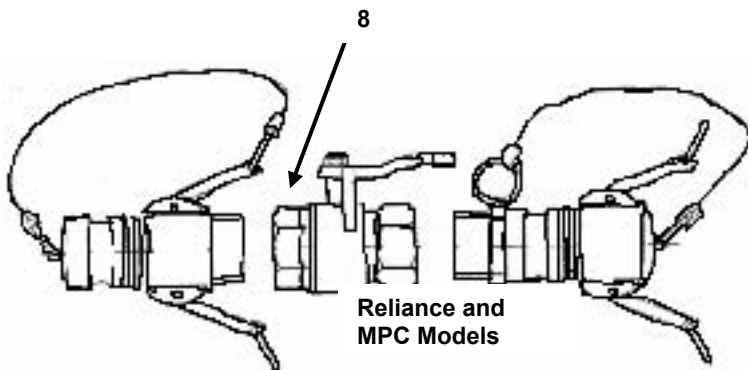
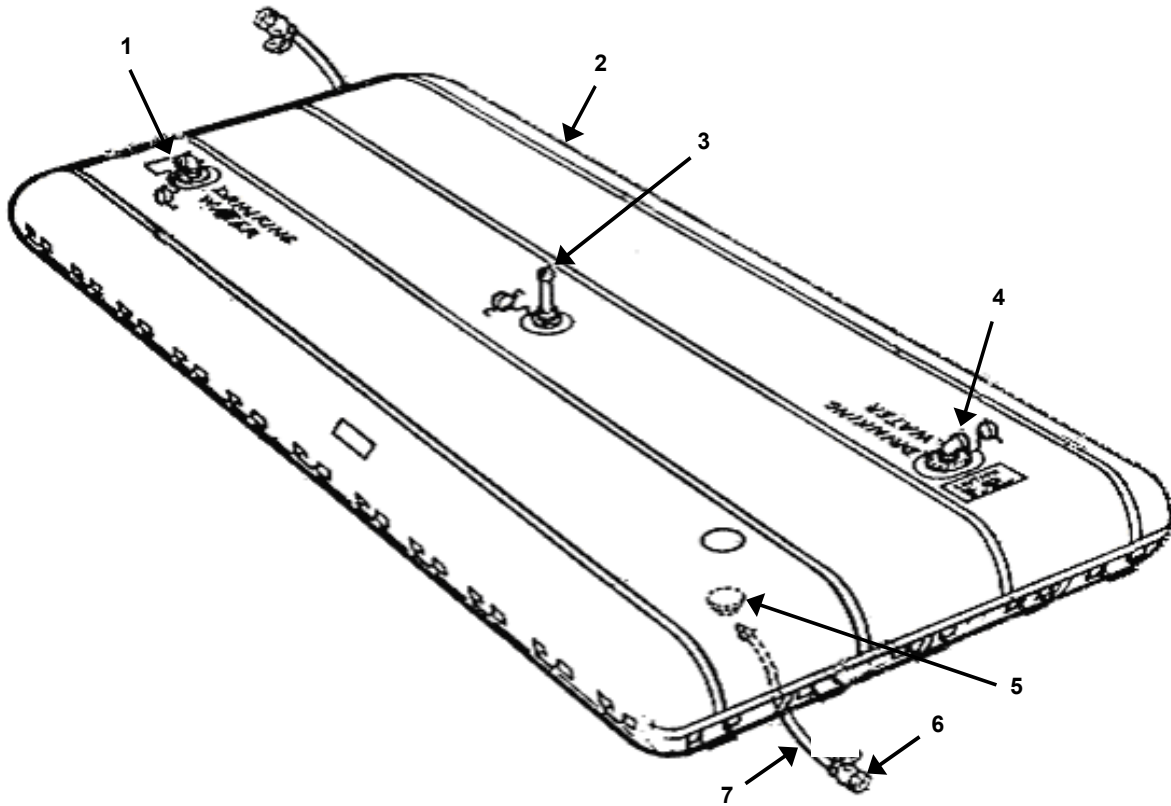

NOTE: Reliance Repair Kit Type III Shown. GTA and MPC are similar.

**Table 1. Operator Preventive Maintenance Checks and Services For 20,000 and 50,000 Gallon Collapsible Water Storage Tanks.**

**NOTE**

Within designated intervals, these checks are to be performed in the order listed.

ITEM NO.	INTERVAL	MAN-HOUR	ITEM TO BE CHECKED OR SERVICED	PROCEDURE	EQUIPMENT NOT READY/ AVAILABLE IF:
1	Before		Installation Area	Inspect the installation area for sticks and other sharp objects that might cause punctures and leaks.	Sharp objects are present.
2	Before		Filler/Discharge Assembly (1)	Inspect for proper connection and loose or missing gaskets. Check fittings for damage or distortion.	Couplings are damaged, leaking or loose. Hose attachments are straining fabric.
3	Before		Tank (2)	Inspect for cuts and punctures. If punctured or torn, perform emergency repairs (see WP 0006 00). Inspect for loose or missing bolts where fittings connect to tank.	Tank is cut, or has tears or punctures that cannot be repaired. Tank has loose or missing bolts.
4	Before		Vent Fitting Assembly (3)	Check vent cap gasket, flat rubber gasket, and cam-lever arms for damage, evidence of leakage, or missing parts. Check vent cap for cleanliness and freedom of movement. Check for damaged or missing gaskets.	Vent cap is damaged or missing. Vent cap gasket, flat rubber gasket, or cam-lever arms are damaged or missing. Vent cap is damaged.
5	Before		Filler/Discharge Assembly, Hose Attachments and Couplings (4)	Inspect for leakage, proper connection, and loose or missing gaskets. Check for cuts and tears. Check for missing dust caps and drain plugs.	Couplings are damaged or loose. Dust caps or plugs missing. Hose attachments straining fabric.
6	Before		Drain Fitting Assembly (5)	Inspect for missing gaskets, chain assembly, or drain plug, damaged coupling arms.	Gaskets or drain plug missing. Coupling arms damaged.
7	Before		Drain Ball Valve Assembly (6)	Inspect for missing valve handle, couplings, dust cap, drain plug, gaskets, and for proper function.	Handle missing; valve does not shut off.

**Table 1. Operator Preventive Maintenance Checks and Services For 20,000 and 50,000 Gallon Collapsible Water Storage Tanks (continued).**

ITEM NO.	INTERVAL	MAN-HOUR	ITEM TO BE CHECKED OR SERVICED	PROCEDURE	EQUIPMENT NOT READY/ AVAILABLE IF:
8	Before		Drain Hose Assembly (7)	Inspect for damaged hose, and damaged or missing gaskets.	Gaskets are missing or damaged. Hose is damaged.
9	Before		Gate/Ball Valve Assembly (8)	Check for bent or binding stem, and broken hardware. Check gaskets and cam lever arms for damage. Check for proper ease of operation. Check for missing or damaged dust caps and plugs.	Stem, hand-wheel or handle, gasket, or cam-lever arms are damaged or missing. Gate/Ball valve will not open/close.
10	During		Filler/Discharge Assembly, Hose Attachments and Couplings (1, 4)	Inspects for leaks at elbow couplings. Check fittings and couplings for distortion or damage.	Hose assembly leaks or components are damaged. Leak is present at coupling.
11	During		Tank (2)	Inspect for cuts, punctures and leaks.	Tank is cut, punctured or leaking.
12	During		Vent Fitting Assembly (3)	Vent cap must move freely and is in a closed position.	Vent cap binds or does not move.
13	During		Drain Ball Valve Assembly (6)	Check for bent, broken, or missing ball valve handle. Check for missing couplings, dust cap, drain plug, gaskets, and for proper function. Check for leakage at ball valve drain.	Ball valve handle is missing, damaged, or leaking. Valve does not shut off.
14	During		Drain Hose Assembly (7)	Inspect for leakage.	Hose assembly leaks or is damaged.
15	During		Gate/Ball Valve Assembly (8)	Check for bent or binding stem, broken hardware, and leakage. Check gasket and ball valve cam-lever arms for damage.	Gate valve stem, hand-wheel, and gasket are missing or damaged. Ball valve cam-lever arms are leaking, missing, or damaged.

**Table 1. Operator Preventive Maintenance Checks and Services For 20,000 and 50,000 Gallon Collapsible Water Storage Tanks (continued).**

ITEM NO.	INTERVAL	MAN-HOUR	ITEM TO BE CHECKED OR SERVICED	PROCEDURE	EQUIPMENT NOT READY/ AVAILABLE IF:
16	After		Filler/Discharge Assembly, Hose Attachments and Couplings (1, 4)	Inspect for damage, leakage, and loose or missing gaskets.	Couplings, hose attachments are damaged, loose, or leaking; gaskets are missing. Hose attachments are straining fabric.
17	After		Tank (2)	Inspect for cuts, punctures and leaks. Loose or missing bolts where fittings connect to tank.	Tank is cut, punctured, or leaks. Loose or missing fitting bolts.
18	After		Vent Fitting Assembly (3)	Check vent cap gasket, flat rubber gasket, and cam-lever arms for damage evidence of leakage, or missing parts. Check vent cap for cleanliness and freedom of movement. Check for damaged or missing gaskets. Inspect vent pipe and fitting for leakage.	Vent cap missing or damaged. Vent cap gasket, flat rubber gasket, or cam-lever arms are damaged or missing. Vent cap binds or is damaged. Vent pipe leaks or is damaged.
19	After		Drain Fitting Assembly (5)	Inspect for missing gaskets, chain, or drain plug, damaged coupling arms. Inspect drain assembly for leakage.	Gaskets or drain plug missing. Coupling arms damaged. Drain fitting leaks or is damaged.
20	After		Drain Ball Valve Assembly (6)	Inspect for missing valve handle, gaskets and for proper function. Inspect valve for leakage.	Handle missing. Valve does not shut off. Drain ball valve leaks or is damaged.
21	After		Drain Hose Assembly (7)	Inspect for damaged or missing gaskets, damaged hose and leakage.	Hose assembly is damaged or leaks. Missing or damaged gaskets.
22	After		Gate/Ball Valve Assembly (8)	Check for proper operation and leakage.	Gate/ball valve leaks or will not open/close.

**Table 1. Operator Preventive Maintenance Checks and Services For 20,000 and 50,000 Gallon Collapsible Water Storage Tanks (continued).**

ITEM NO.	INTERVAL	MAN-HOUR	ITEM TO BE CHECKED OR SERVICED	PROCEDURE	EQUIPMENT NOT READY/ AVAILABLE IF:
23	After		Repair Kit (9)	Check for missing components.	Repair items are missing.
24	Weekly		Filler/Discharge Assembly, Hose Attachments and Couplings (1, 4)	Inspect for damage, leakage, and loose or missing gaskets.	Fittings or hose attachments are damaged, loose or leaking, or gaskets are missing.
25	Weekly		Tank (2)	Inspect for cuts, punctures and leaks.	Tank is cut, punctured or leaking.
26	Weekly		Vent Fitting Assembly (3)	Inspect vent fitting assembly vent flap for movement. Inspect vent pipe assembly for leakage.	Vent flap sticks or binds. Vent pipe leaks or is damaged.
27	Weekly		Gate/Ball Valve Assembly (8)	Check for proper operation and leakage.	Gate/ball valve leaks or will not open/close.
28	Weekly		Repair Kit (9)	Check for missing components. Make sure instruction information is present.	Repair items are missing.
29	Semi-annually		Tank Interior (not shown)	Check interior tank coating for cracking.	Coating is cracked, allowing leakage.

**END OF WORK PACKAGE**





---

**OPERATOR AND UNIT MAINTENANCE MANUAL  
(INCLUDING REPAIR PARTS AND SPECIAL TOOLS LIST)  
TANK, FABRIC, COLLAPSIBLE, WATER STORAGE,  
20,000 AND 50,000 GALLONS  
OPERATOR MAINTENANCE PROCEDURES**

---

**GENERAL INSTRUCTIONS**

Operator maintenance is limited to the replacement of damaged or missing gaskets on all quick - disconnect couplings and to performing emergency tank repairs using wood plugs and sealing clamps (WP 0006 00).

Maintenance instructions in this section will list resources and personnel required, for start of procedure, except as noted below:

**NOTE**

Personnel required are listed only if the task requires more than one.

**EQUIPMENT**

**MAINTENANCE PROCEDURE**

Filler/Discharge Gate Valve (GTA Container Model), Hose Assembly.....	WP 0012 00
Coupling and Dust Cap Gasket	
Filler/Discharge Ball Valve Gasket (Reliance and MPC Models) .....	WP 0013 00
Vent Fitting Assembly Coupling and Dust Cap Gasket .....	WP 0014 00
Filler/Discharge Assembly Elbow and Dust Cap Gasket .....	WP 0015 00

**END OF WORK PACKAGE**



**OPERATOR MAINTENANCE  
TANK, FABRIC, COLLAPSIBLE, WATER STORAGE,  
20,000 AND 50,000 GALLONS  
FILLER/DISCHARGE GATE VALVE (GTA CONTAINER MODEL),  
HOSE ASSEMBLY COUPLING AND DUST CAP GASKET  
REPLACEMENT**

**INITIAL SETUP****Mandatory Replacement Parts**

Gasket  
(Item 1, WP 0041 00)

**REMOVAL**

The filler/discharge hose is fitted with a female quick-disconnect coupling on one end and a male quick-disconnect adapter on the other end.

1. Pull two cam-lever arms (1) outward on female quick-disconnect coupling (2), and hose assembly coupling (3). Disconnect hose assembly (4) from filler/discharge valve assembly (5).
2. Remove coupling gasket (6) from inside female quick-disconnect coupling (2). Discard gasket (6).
3. Remove hose assembly gasket (7) from inside hose coupling (8). Discard gasket (7).
4. Remove dust cap (9). Remove gasket (10) from dust cap (9). Discard gasket (10).

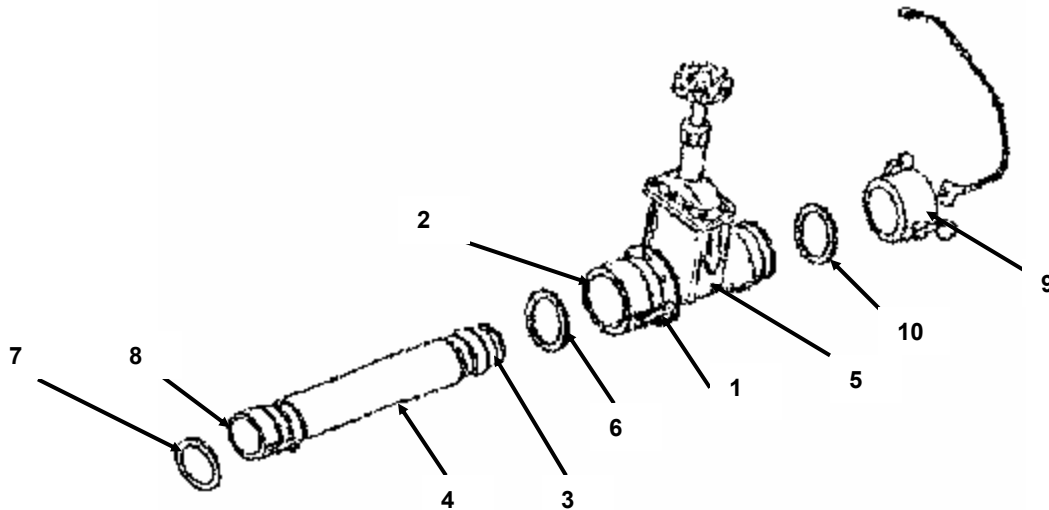
**INSTALLATION**

1. Install new gasket (10) in dust cap (9). Install dust cap (9).
2. Install new hose assembly gasket (7) inside hose coupling (8).
3. Install new coupling gasket (6) inside female quick-disconnect coupling (2).
4. Connect hose assembly (4) to filler/discharge valve assembly (5).
5. Push in on cam-lever arms (1) to lock hose assembly (4) in place.

**END OF WORK PACKAGE**



---

**OPERATOR MAINTENANCE  
TANK, FABRIC, COLLAPSIBLE, WATER STORAGE,  
20,000 AND 50,000 GALLONS  
FILLER/DISCHARGE BALL VALVE GASKET  
(RELIANCE AND MPC MODELS)  
REPLACEMENT**

---

**INITIAL SETUP****Mandatory Replacement Parts**

Gasket  
(Item 2, WP 0041 00)

---

**REMOVAL**

1. Pull cam-lever arms (1) on dust cap (2) out, away from body of dust cap (2).
2. Remove dust cap (2) from male coupling (3). Remove gasket (4) from dust cap (2).
3. Pull cam-lever arms (5) on female coupling (6) out, away from body of female coupling (6).
4. Remove dust plug (7) from female coupling (6). Remove gasket (8) from dust plug (7).
5. Discard gaskets (4, 8).

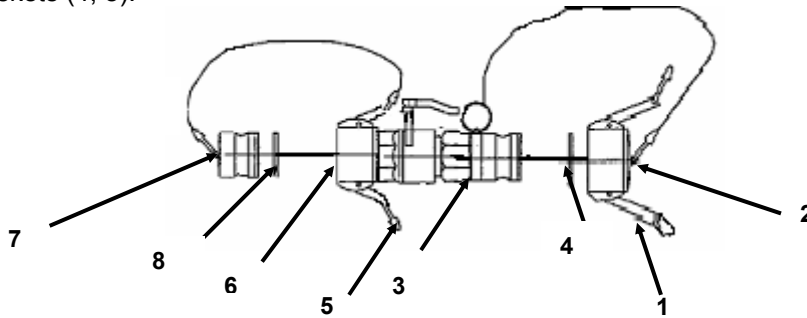
**INSTALLATION**

1. Install new gasket (8) on dust plug (7).
2. Push cam-lever arms (5) on female coupling (6) outward, away from body of female coupling (6).
3. Install dust plug (7) in female coupling (6).
4. Push cam-lever arms (5) on female coupling (6) inward toward body of female coupling (6) until locked.
5. Install new gasket (4) on dust cap (2).
6. Push cam-lever arms (1) on dust cap (2) outward, away from body of dust cap (2).
7. Install dust cap (2) on male coupling (3).
8. Push cam-lever arms (1) on dust cap (2) inward toward body of dust cap (2) until locked.

**END OF WORK PACKAGE**



---

**OPERATOR MAINTENANCE  
TANK, FABRIC, COLLAPSIBLE, WATER STORAGE,  
20,000 AND 50,000 GALLONS  
VENT FITTING ASSEMBLY COUPLING AND DUST CAP GASKET  
REPLACEMENT**

---

**INITIAL SETUP****Mandatory Replacement Parts**

Gasket  
(Item 3, WP 0041 00)

---

**REMOVAL**

1. Disconnect female quick-disconnect coupling (1) from male-flanged adapter (2) by pulling outward on cam-lever arms (3). Lift female quick-disconnect coupling (1) from male-flanged adapter (2).
2. Remove female quick-disconnect coupling gasket (4). Discard gasket (4).
3. Remove gasket (5) from inside dust cap (6). Discard gasket (5).

**NOTE**

Vent pipe and vent relief cap removed for clarity.

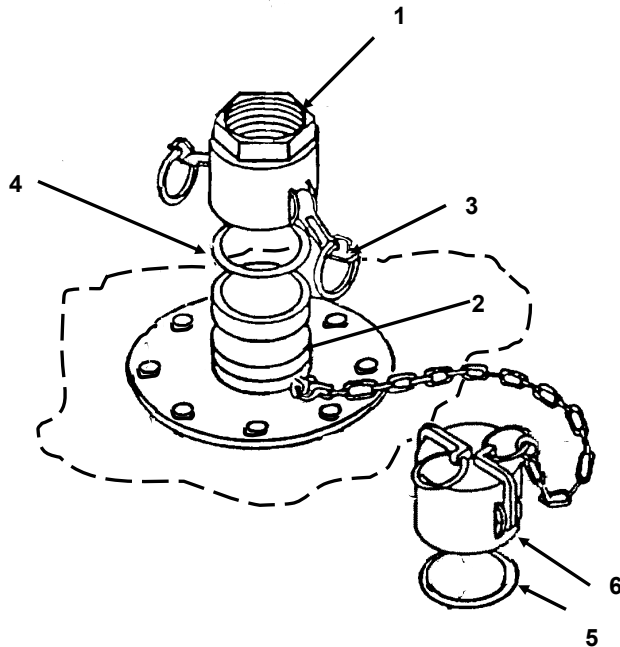

**INSTALLATION**

1. Seat new coupling gasket (4) into female quick-disconnect coupling (1).
2. With cam-lever arms (3) in the outward position, install female quick-disconnect coupling (1) to male-flanged adapter (2).
3. Push cam-lever arms (3) inward until they lock in place.
4. Seat new gasket (5) into dust cap (6).

**END OF WORK PACKAGE**



**OPERATOR MAINTENANCE  
TANK, FABRIC, COLLAPSIBLE, WATER STORAGE,  
20,000 AND 50,000 GALLONS  
FILLER/DISCHARGE ASSEMBLY ELBOW AND DUST CAP GASKET  
REPLACEMENT**

**INITIAL SETUP****Mandatory Replacement Parts**

Gasket  
(Item 1, WP 0041 00)

**REMOVAL**

1. Remove elbow (1) or dust cap (2) by pulling outward on cam-lever arms (3), and lifting elbow (1) or dust cap (2) from flanged adapter (4).

**NOTE**

Filler end female/female elbow has two gaskets.

2. Remove gasket (5) from elbow (1) and gasket (6) from dust cap (2). Discard gaskets (5) and (6).

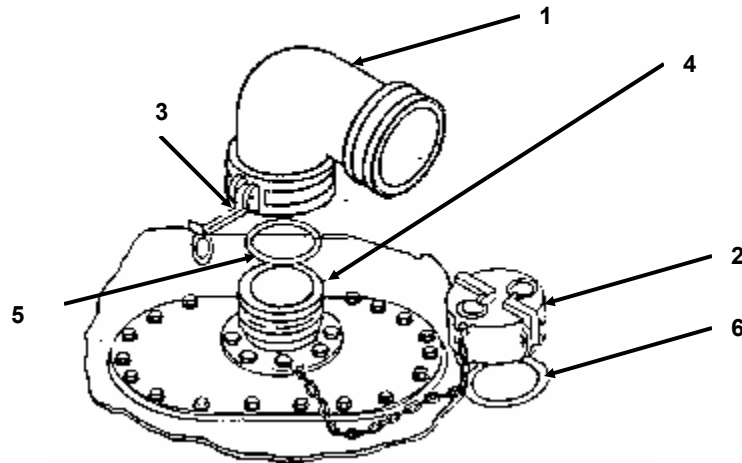
**INSTALLATION****NOTE**

Filler end female/female elbow will require two new gaskets.

1. Place new gasket (5) into elbow (1) and new gasket (6) in dust cap (2).
2. Install elbow (1) onto flanged adapter (4), by pushing inward on cam-lever arms (3) to lock elbow (1) into position.
3. Install the dust cap (2) onto the elbow (1) by pushing inward on the cam-lever arms (3) on dust cap (2) to lock into position.

**END OF WORK PACKAGE**



**CHAPTER 5**

**UNIT MAINTENANCE INSTRUCTIONS**  
**FOR**  
**TANK, FABRIC, COLLAPSIBLE, WATER STORAGE,**  
**20,000 and 50,000 GALLONS**



---

**UNIT MAINTENANCE  
TANK, FABRIC, COLLAPSIBLE, WATER STORAGE,  
20,000 AND 50,000 GALLONS  
LUBRICATION INSTRUCTIONS**

---

**LUBRICATION INSTRUCTIONS**

Lubrication not required.

**END OF WORK PACKAGE**



---

**UNIT MAINTENANCE INSTRUCTION  
TANK, FABRIC, COLLAPSIBLE, WATER STORAGE, 20,000 AND 50,000 GALLONS  
UNIT REPAIR; TOOLS; SPECIAL TOOLS; TEST, MEASUREMENT AND DIAGNOSTIC EQUIPMENT  
(TMDE); AND SUPPORT EQUIPMENT**

---

**COMMON TOOLS AND EQUIPMENT**

For authorized common tools and equipment, refer to the Modified Table of Organization and Equipment (MTOE) applicable to your unit.

**SPECIAL TOOLS, TMDE, AND SUPPORT EQUIPMENT**

No special tools or TMDE are required to maintain the 20,000 and 50,000 Gallon Collapsible Fabric Water Tank systems. Support equipment consists of the Emergency Type III Repair Kit (Table 1, WP 0038 00).

**REPAIR PARTS**

Repair parts are listed and illustrated in WP 0035 00 of this manual.

**END OF WORK PACKAGE**





---

**UNIT MAINTENANCE INSTRUCTION  
TANK, FABRIC, COLLAPSIBLE, WATER STORAGE,  
20,000 AND 50,000 GALLONS  
UNIT SERVICE UPON RECEIPT**

---

**SITING**

Refer to WP 0005 00.

**SERVICE UPON RECEIPT OF MATERIEL**

If the 20K tanks are supplied as part of a 40K Water Distribution System, the water tank may be packaged in a reusable container.

Inspect the equipment for damage incurred during shipment. Refer to Table 1. If the equipment has been damaged, report the damage in accordance with the instructions of DA PAM 738-750.

Check the equipment against the packing slip to see if the shipment is complete. Report all discrepancies in accordance with the instructions of DA PAM 738-750.

Check to see whether the equipment has been modified.

**Table 1. Checks Upon Receipt of Materiel.**

LOCATION	ITEM	ACTION
		<p><b>NOTE</b></p> <p>All attached fittings are wrapped with permanently attached cushioning material.</p>
Tank Body	Tank Body	Present. No cuts or cracks.
Tank Body	Drain Assembly	Assembly is present and sealed by plug.
Tank Body	Filler and Discharge Couplings	Assemblies are present and sealed by dust caps.
Tank Body	Vent Coupling	Assembly present and sealed by its dust cap.
Tank Body	Vent Cap	Vent cap is present and flap moves easily. Gasket present inside cap.
Tank Body	Vent Pipe, 2-inch Diameter	Present and threads undamaged.
Tank Body	Coupling Half	Present and threads undamaged. Gasket present inside coupling.
Tank Body	Elbow, Female/female	Present and with gaskets.
Tank Body	Elbow, Female/male	Present and with gasket.
Accessories	Two 8 Ft. x 2-inch Drain Hoses and two 2-inch Ball Valves	Present and undamaged.
Accessories	10 Ft. x 4-Inch of Filler Discharge Hose	Present and undamaged.
Accessories	4 Inch Gate Valve (GTA Container Models) with 2 Coupling Halves, 2 x 4-inch flange gaskets, 1 Dust Cap & 1 Dust Plug	Present, undamaged and containing 4 gaskets.
Accessories	4 Inch Ball Valve (Reliance and MPC Models) with 2 Coupling Halves, Dust Cap and gasket & 1 Dust Plug and gasket	Present, undamaged and containing 2 gaskets.
Accessories	2 Inch Ball Valve with 2 Coupling Halves, 1 Dust Cap & 1 Dust Plug 1 Coupling gasket and 1 Dust Cap gasket	Present and undamaged.
Accessories	Repair Kit, Type III	Present and undamaged.
Accessories	On-Board Spare Parts	Present
Accessories	Ground Cloth, if Equipped	
Accessories	Hand Receipt & Manual	Present

**INSTALLATION INSTRUCTIONS**

Refer to WP 0005 00.

**PRELIMINARY SERVICING AND ADJUSTMENT OF EQUIPMENT**

No preliminary servicing or adjustment is required.

**END OF WORK PACKAGE**



---

**UNIT MAINTENANCE  
TANK, FABRIC, COLLAPSIBLE, WATER STORAGE,  
20,000 AND 50,000 GALLONS  
UNIT PMCS PROCEDURES**

---

## **INTRODUCTION**

### **General**

Preventive Maintenance Checks and Services (PMCS) are performed to keep the collapsible fabric water tank assembly in operating condition. The checks are used to find, correct or report problems. Be sure to perform PMCS each time you service the tank assembly. Using the PMCS table, always do PMCS in the same order so it gets to be a habit. With practice, you'll quickly spot anything wrong. Pay close attention to WARNING and CAUTION statements. A WARNING means someone could be hurt. A CAUTION means equipment could be damaged.

Before you use the tank assembly, do "Before" PMCS.

During tank use, do "During" PMCS.

After the tank assembly is used, do "After" PMCS.

Do "Weekly" PMCS once a week.

Do "Quarterly" PMCS once every three months.

Do "Semi-annually" PMCS once every six months.

If you find something wrong when performing PMCS, fix it if you can, using troubleshooting procedures and/or maintenance procedures.

Use DA Form 2404 (Equipment Inspection and Maintenance Worksheet) to record any faults that you discover before, during, or after operation, unless you can fix them. You do not need to record faults that you fix. For further information on how to use DA Form 2404, see DA PAM 738-750.

### **PMCS Procedures**

Your Preventive Maintenance Checks and Services, Table 1, lists the inspections and care required to keep the water tank assembly in good operating condition.

The "Interval" column of Table 1 indicates when a certain check or service should be performed.

#### **NOTE**

When a check and service procedure is required for both "Before" and "Weekly" intervals, it is not necessary to perform the "Weekly" procedure during the same week in which the "Before" procedure was done.

The "Procedure" column of Table 1 tells you how to do the required checks and services. Carefully follow these instructions. When the procedure tells you to, notify your supervisor.

The "Equipment Not Ready/Available If" column of Table 1 tells you when and why your equipment cannot be used.

### **PMCS Leakage Definitions**

It is necessary for you to know how fluid leakage affects the status of the collapsible fabric water tank. Following are types/causes of leakage you need to know to be able to determine the status of the collapsible water tank. Learn these leakage definitions and remember – when in doubt, notify your supervisor.

## CAUTION

- **Report Class III and IV leaks should be to your supervisor or to Unit Maintenance. Failure to heed this Caution can cause damage to the equipment.**

## NOTES

- Equipment operation is allowed with minor leakages (Class I or II). Consideration must be given to fluid capacity in the item/system being checked/inspected. When in doubt, notify your supervisor.
- When operating with Class I or II leaks, continue to check fluid levels as required in PMCS.

Class I	Seepage of water (as indicated by wetness or discoloration not great enough to form drops.
Class II	Leaks of water great enough to form drops but not enough to cause the drops to drip or run from the faulty area.
Class III	Leaks of water great enough to form drops that fall or run, or collect in puddles near the faulty area.
Class IV	Leaks found under the tank. There is evidence of dampness on the ground around the tank. Volume of water in tank is less than it should be.

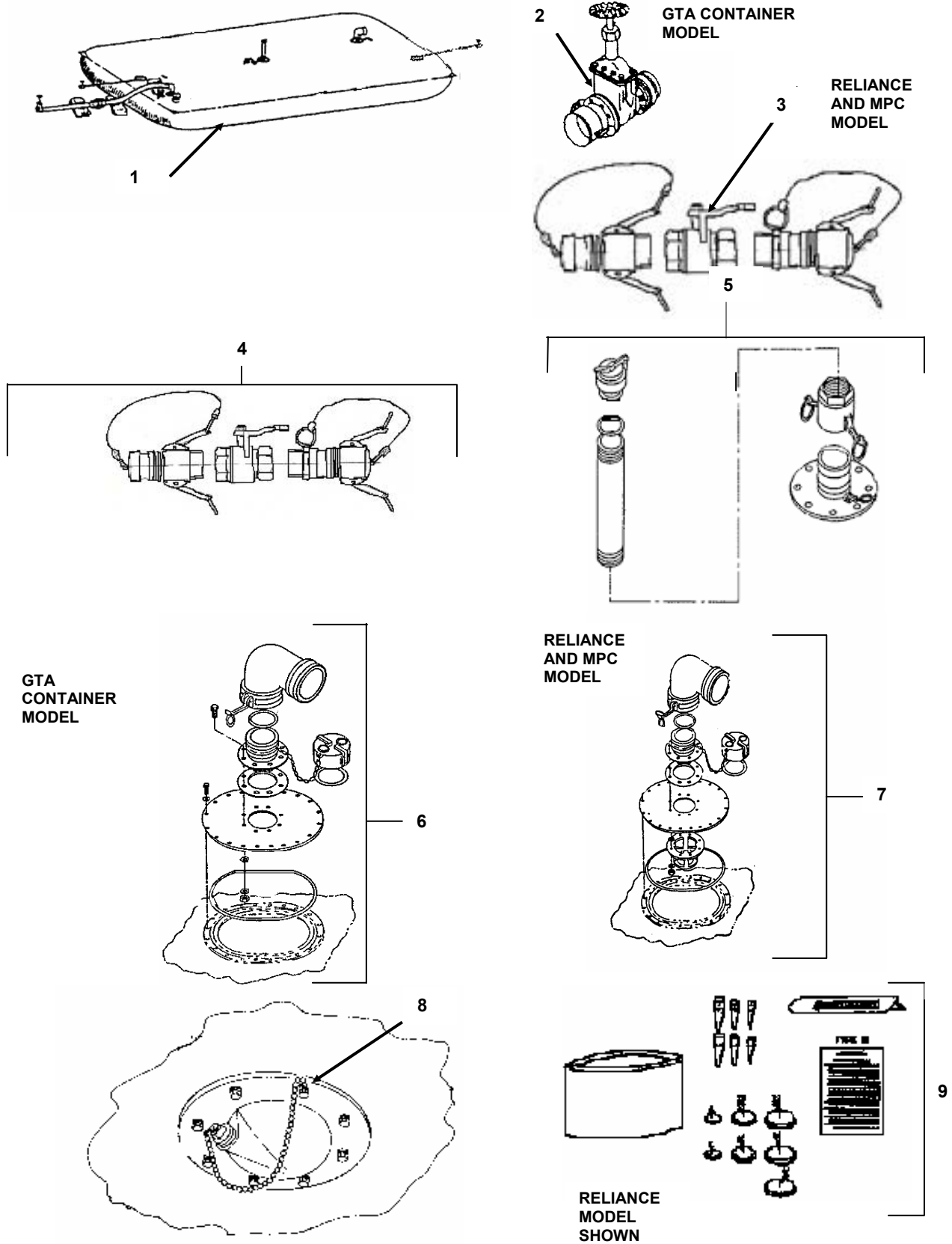

Unit Preventive Maintenance Checks and Services Components

**Table 1. Unit Preventive Maintenance Checks and Services For 20,000 and 50,000 Gallon Collapsible Water Storage Tanks.**

**NOTE**

Within designated intervals, these checks are to be performed in the order listed.

ITEM NO.	INTERVAL	MAN-HOUR	ITEM TO BE CHECKED OR SERVICED	PROCEDURE	EQUIPMENT NOT READY/ AVAILABLE IF:
1	Before		Tank (1)	Inspect for tears or punctures.	Torn or punctured.
2	Before		Filler/Discharge Gate Valve (2) or Ball Valve (3)	Check for bent or binding stem, broken hand-wheel or handle.	Stem, hand-wheel or handle are damaged or missing.
3	Before		Drain Ball Valve (4)	Check for bent or binding stem or broken handle.	Stem or handle are damaged or missing.
4	Before		Vent Fitting Assembly (5)	Check for evidence of damage or missing parts. Check the vent cap for cleanliness and freedom of operation. Check if the vent cap gasket, flat rubber gasket or cam-lever arms are damaged or missing.	Vent cap is damaged or missing. Vent cap gasket, flat rubber gasket or cam-lever arms are damaged or missing.
5	Before		Filler/Discharge Assembly (6) (GTA Container Model) or Filler/Discharge Assembly (7) (Reliance and MPC Models)	Check for evidence of damage. Check if cam-lever arms are damaged or missing. Check if the elbow body is cracked or sealing surface is badly dented. Check for loose, damaged or missing screws and gaskets.	Cam-lever arms are damaged or missing. Elbow body is cracked. Elbow sealing surface is badly dented. Hardware damaged or missing.
6	Before		Drain Fitting Assembly (8)	Check drain plug, drain hose, and drain ball valve, for damaged or missing parts.	Drain plug, hose, or ball valve missing, not connected, or damaged.
7	During		Tank (1)	Inspect for tears, leaks, or punctures (exclude weeping/wicking where the tank seams are not involved and droplets do not form or run down the side of the tank).	Tank has tears or punctures that cannot be repaired.



**Table 1. Unit Preventive Maintenance Checks and Services For 20,000 and 50,000 Gallon Collapsible Water Storage Tanks (continued).**

ITEM NO.	INTERVAL	MAN-HOUR	ITEM TO BE CHECKED OR SERVICED	PROCEDURE	EQUIPMENT NOT READY/ AVAILABLE IF:
8	During		Filler/Discharge Gate Valve (2) or Ball Valve (3)	Check for bent or binding stem, broken hand-wheel or handle, and leakage.	Stem, hand-wheel or handle, gasket, or cam-lever arms leak or are damaged or missing.
9	During		Drain Ball Valve (4)	Check for bent or binding stem, broken handle, and leakage.	Stem or handle leak or are damaged or missing.
10	During		Vent Fitting Assembly (5)	Check for evidence of leakage, damage, or missing parts. Check the vent cap for cleanliness and freedom of operation. Check if the vent cap gasket, flat rubber gasket, or cam-lever arms are damaged or missing.	Vent cap is damaged or missing. Vent cap gasket, flat rubber gasket, or cam-lever arms are damaged or missing.
11	During		Filler/Discharge Assembly (6) (GTA Container Model) or Filler/Discharge Assembly (7) (Reliance and MPC Models)	Check for evidence of damage or leakage. Check if cam-lever arms are damaged or missing. Check if the elbow body is cracked or sealing surface is badly dented. Check for loose, damaged or missing screws and gaskets.	Cam-lever arms are damaged or missing. Elbow body is cracked. Elbow sealing surface is badly dented.
12	During		Drain Fitting Assembly (8)	Check immediate area for evidence of leakage. Check the drain plug, drain hose, or drain valve, for damaged or missing parts.	Drain plug, hose, or valve is missing, improperly connected, or damaged.
13	After		Tank (1)	Inspect for tears, punctures, or leaks.	Tank has tears or punctures that cannot be repaired.

**Table 1. Unit Preventive Maintenance Checks and Services For 20,000 and 50,000 Gallon Collapsible Water Storage Tanks (continued).**

ITEM NO.	INTERVAL	MAN-HOUR	ITEM TO BE CHECKED OR SERVICED	PROCEDURE	EQUIPMENT NOT READY/ AVAILABLE IF:
14	After		Filler/Discharge Gate Valve (2) or Ball Valve (3)	Check for bent or binding stem, broken hand-wheel or handle.	Stem, hand-wheel or handle are damaged or missing.
15	After		Drain Ball Valve (4)	Check for bent or binding stem, or broken handle.	Stem or handle are damaged or missing.
16	After		Vent Fitting Assembly (5)	Check for evidence of leakage, damage, or missing parts. Check the vent cap for cleanliness and freedom of operation. Check if the vent cap gasket, flat rubber gasket, or cam-lever arms are damaged or missing.	Any evidence of leakage. Vent cap is damaged or missing. Vent cap gasket, flat rubber gasket, or cam-lever arms are damaged or missing.
17	After		Filler/Discharge Assembly (6) (GTA Container Model) or Filler/Discharge Assembly (7) (Reliance and MPC Models)	Check for evidence of damage or leakage. Check if cam-lever arms are damaged or missing. Check if the elbow body is cracked or sealing surface is badly dented. Check for loose, damaged or missing screws and gaskets.	Any evidence of leakage. Cam-lever arms damaged or missing. Elbow body cracked or worn.
18	Quarterly		Tank (1)	Inspect for cuts, punctures and leaks. Loose or missing bolts where fittings connect to tank.	Tank is cut, punctured or leaks. Loose or missing fitting bolts.
19	Quarterly		Filler/Discharge Gate Valve (2) or Ball Valve (3)	Check for proper operation and leakage. Check for bent, broken, or binding parts. Check for leakage.	Valve will not open/close. Component parts are missing or damaged. Valve leaks or is damaged.

**Table 1. Unit Preventive Maintenance Checks and Services For 20,000 and 50,000 Gallon Collapsible Water Storage Tanks (continued).**

ITEM NO.	INTERVAL	MAN-HOUR	ITEM TO BE CHECKED OR SERVICED	PROCEDURE	EQUIPMENT NOT READY/ AVAILABLE IF:
20	Quarterly		Vent Fitting Assembly (5)	Inspect for evidence of leakage, damage, or missing parts. Check the vent cap for cleanliness and freedom of operation. Check if the vent cap gasket, flat rubber gasket, or cam-lever arms are damaged or missing.	Any evidence of leakage. Vent cap is damaged or missing. Vent cap gasket, flat rubber gasket, or cam-lever arms are damaged or missing.
21	Quarterly		Filler/Discharge Assembly Couplings and Hose Attachments (6, 7)	Inspect for proper connection, leakage, and loose or missing gaskets.	Couplings are damaged or loose. Hose fittings straining fabric. Hose is leaking or damaged.
22	Quarterly		Drain Fitting Assembly (8)	Inspect for missing gaskets or damaged coupling arms.	Gaskets missing or damaged coupling arms.
23	Quarterly		Type III Repair Kit (9)	Check for missing components.	Repair items are missing.
24	Quarterly		Ground Cloth	Inspect for punctures or tears.	Ground cloth is damaged.
25	Semi-annually		Drain Fitting Assembly (8)	Check immediate area for evidence of leakage. Check drain plug, hose, or ball valve for damaged or missing parts.	Any evidence of leakage. Drain plug, hose, and ball valve are missing, improperly connected, or damaged.

**END OF WORK PACKAGE**



---

**OPERATOR AND UNIT MAINTENANCE MANUAL  
(INCLUDING REPAIR PARTS AND SPECIAL TOOLS LIST)  
TANK, FABRIC, COLLAPSIBLE, WATER STORAGE,  
20,000 AND 50,000 GALLONS  
UNIT MAINTENANCE PROCEDURES**

---

## GENERAL INSTRUCTIONS

Maintenance instructions in this section will list resources required and equipment conditions for start of procedure, except as noted below:

- Personnel required are listed only if the task requires more than one individual.
- The normal standard equipment condition to start a maintenance task is collapsible water tank drained and deflated. Equipment condition is not listed unless some other condition is required.

## CAUTION

**The collapsible water tank must be empty before performing maintenance on these units. Be careful when walking on fabric. Gravel and sand on the bottom of boots will damage fabric.**

## PERSONNEL SAFETY

- To ensure safety of personnel, proper care should be used when handling assemblies and parts. Many assemblies are heavy. The assistance of additional personnel, lifting devices or other support equipment may be required to move or position heavy items.
- Personnel must remove all items of jewelry (rings, bracelets, watches, necklaces, etc.) and loose clothing before working on the equipment. Jewelry and loose clothing can get caught in equipment and result in damage to equipment or injury to personnel.
- When performing maintenance on the collapsible water tank, keep in mind that the purpose of the equipment is to store water for drinking. Cleaning fluids, lubricants, preservatives, paint or other chemicals must not be allowed to contaminate the water.
- Operate the equipment after performing maintenance to ensure repairs have been performed correctly and equipment can be returned to service.

## PROPER EQUIPMENT

Obtain proper equipment before beginning maintenance. This includes hand tools and/or special tools, receptacles for storing small parts, and expendable materials required by the maintenance task. Maintenance of the collapsible water tank system is limited to replacement and repair. Replacement consists of turning the equipment in at the proper supply point and then requisitioning a replacement unit. Repair is accomplished by replacing or repairing components that make up the system.

**EQUIPMENT**

**MAINTENANCE PROCEDURE**

Filler/Discharge Gate Valve Assembly (GTA Container Model) ..... WP 0021 00

Filler/Discharge Ball Valve Assembly (Reliance and MPC Models) ..... WP 0022 00

Filler/Discharge Hose Assembly ..... WP 0023 00

Drain Hose Assembly ..... WP 0024 00

Vent Fitting Assembly ..... WP 0025 00

Filler/Discharge Assembly (GTA Container Model) ..... WP 0026 00

Filler/Discharge Assembly (Reliance and MPC Models) ..... WP 0027 00

Drain Fitting Assembly ..... WP 0028 00

Ground Cloth Maintenance ..... WP 0029 00

Emergency Repair Kit Maintenance ..... WP 0030 00

Preparation for Storage or Shipment ..... WP 0031 00

**END OF WORK PACKAGE**

---

**UNIT MAINTENANCE**  
**TANK, FABRIC, COLLAPSIBLE, WATER STORAGE**  
**20,000 AND 50,000 GALLONS**  
**FILLER/DISCHARGE GATE VALVE ASSEMBLY**  
**(GTA CONTAINER MODEL)**  
**REMOVAL, SERVICE, REPAIR AND INSTALLATION**

---

**INITIAL SETUP****Tools**

Tool Kit, General Mechanics  
 (Item 1, WP 0033 00)  
 Torque Wrench, (in-lb)  
 (Item 2, WP 0033 00)  
 Torque Wrench, (ft-lb)  
 (Item 3, WP 0033 00)

**Materials/Parts**

Crocus Cloth  
 (Item 1, WP 0039 00)  
 Detergent, General Purpose  
 (Item 2, WP 0039 00)  
 Grease  
 (Item 3, WP 0039 00)  
 Rag, Wiping  
 (Item 4, WP 0039 00)

**Mandatory Replacement Parts**

Gasket  
 (Item 1, WP 0041 00)  
 Gaskets  
 (Item 4, WP 0041 00)  
 Gasket, Valve Bonnet  
 (Item 5, WP 0041 00)  
 Lockwashers  
 (Item 6, WP 0041 00)  
 Lockwashers  
 (Item 7, WP 0041 00)

**REMOVAL****Hose Assembly, Coupling and Adapter**

1. Remove hose assembly (1) from gate valve assembly (2) by pulling two cam-lever arms (3) outward on female quick-disconnect coupling (4).
2. Remove the chain and dust plug (5) from female quick-disconnect coupling (4), and the chain and dust cap (6) from male-flanged adapter (7). Remove gasket (8) from male-flanged adapter (7).
3. Remove coupling gasket (9) from inside female quick-disconnect coupling (4).
4. Remove eight hex nuts (10), lockwashers (11), hex-head cap screws (12), and washers (13) from face of gate valve (14).
5. Remove female quick-disconnect coupling (4) and flange gasket (15) from face of gate valve (14).
6. Remove eight hex nuts (16), lockwashers (17), hex-head cap screws (18), and washers (19) from the opposite end of gate valve (14).
7. Remove male-flanged adapter (7) and flange gasket (20) from gate valve (14).
8. Discard flange gaskets (15) and (20).

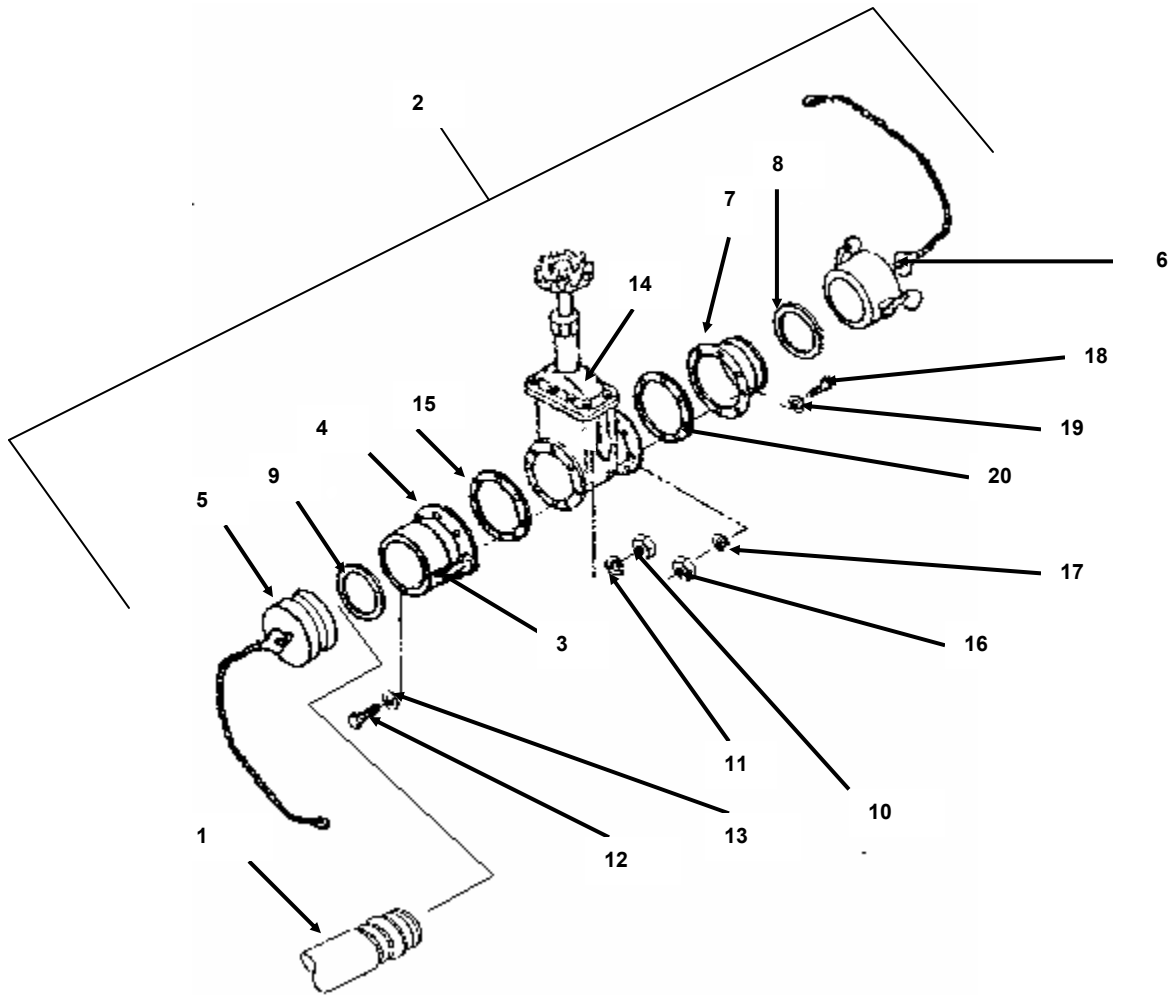

## DISASSEMBLY

### Gate Valve

1. Remove jam nut (1) from the top of hand-wheel (2).
2. Remove hand-wheel (2) from the top of valve stem (3).
3. Remove packing nut (4) from bonnet (5).
4. Remove packing gland (6) and gland spring (7) from valve stem (3).

### NOTE

The packing ring will remain in the bonnet until the valve stem, the disk riser, and the disk halves have been removed from the bonnet.

5. Remove eight hex nuts (8), lockwashers (9), and hex-head cap screws (10) holding bonnet (5) to valve body (11).



**CAUTION**

Keep the disk halves together when removing from the valve body. Disk halves must be grasped firmly when disassembled from the valve body. Dropping the disk halves off the disk riser can damage the sealing surfaces. As the discs clear the slots in the valve body, hold them together with the right hand in order to avoid dropping off the disk stem and damaging the sealing surface.

6. Lift bonnet (5) with valve stem (3), disk riser (12), and disk halves (13) and (14) from valve body (11).

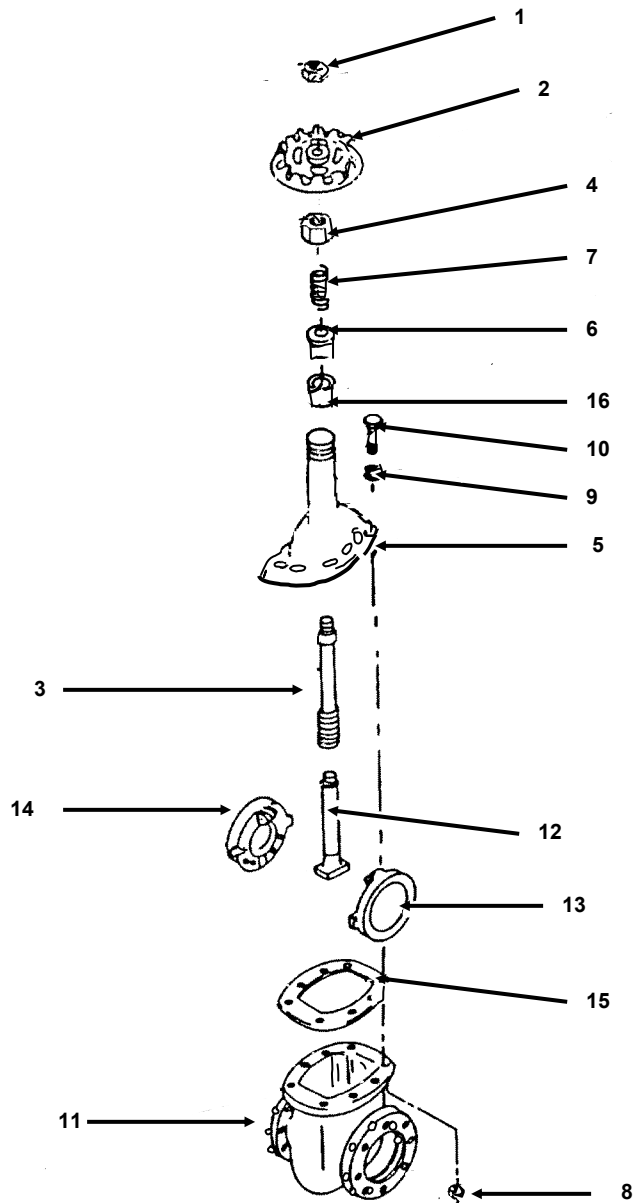

7. Remove bonnet gasket (15) from valve body (11).
8. Rotate disk riser (12) counterclockwise, and disassemble disk riser (12) from valve stem (3).

9. Rotate valve stem (3) clockwise, and disassemble valve stem (3) from the bottom side of bonnet (5).

#### NOTE

The packing ring should be removed only when it is to be replaced.

10. Drive packing ring (16) through the bottom of bonnet (5).

#### SERVICE

1. Clean all parts with detergent and warm water. Dry thoroughly with rags.
2. Clean all gasket-sealing surfaces thoroughly with detergent and hot water.
3. Inspect all mechanical parts for cracks, dents, breaks, and excessive wear. Replace components if unserviceable.
4. Polish valve stem (3) with crocus cloth. Coat valve stem (3) with grease.

#### ASSEMBLY

##### Gate Valve

1. Thread disk riser (12) into valve stem (3).
2. Check that disk riser (12) is completely secured to bonnet (5).
3. Lay valve body (11) on its side on a clean surface. Position new bonnet gasket (15) over disk riser (12).
4. Install disk halves (13) and (14) onto disk riser (12).
5. Insert disk halves (13) and (14) into valve body (11) slot.
6. Place valve body (11) and bonnet (5) in an upright position.
7. Align valve body (11) to bonnet gasket (15). Install bonnet (5) assembly to valve body (11) with eight hex-head cap screws (10), new lockwashers (9), and hex nuts (8).
8. Insert packing ring (16) onto valve stem (3).
9. Insert packing nut (4) onto valve stem (3) by pushing packing nut (4) down on the neck of bonnet (5) until packing ring (16) is seated in bonnet (5).
10. Remove packing nut (4) from valve stem (3), and assemble gland spring (7) and packing gland (6) to valve stem (3).
11. Insert packing nut (4), hand-wheel (2), and jam nut (1) onto the valve stem (3).
12. Torque hex-head cap screws (10), lockwashers (9), and hex nuts (8) assembled to the valve body (11) to 16 ft-lb (21.70 Nm).

## INSTALLATION

### Hose Assembly, Coupling and Adapter

1. Position new flange gasket (20) on the face of gate valve (14), and align the holes.
2. Position male-flanged adapter (7) against flange gasket (20), and align the holes.
3. Install washers (19) and hex-head cap screws (18) onto male-flanged adapter (7), flange gasket (20), and gate valve (14).
4. Install new lockwashers (17), and hex nuts (16) onto gate valve (14). Torque nuts (16) to 30 in-lb (3.41N•m).
5. At the opposite end of gate valve (14), position new flange gasket (15) against gate valve (14).
6. Position female quick-disconnect coupling (4) against flange gasket (15) and align the holes.
7. Install washers (13) and hex-head cap screws (12) onto female quick-disconnect coupling (4), flange gasket (15), and the face of gate valve (14).
8. Install new lockwashers (11) and hex nuts (10) onto hex-head cap screws (12). Torque nuts (10) to 30 in-lb (3.41N•m).
9. Lubricate new coupling gasket (9), and install coupling gasket (9) on the inside of female quick-disconnect coupling (4).
10. Install new gasket (8) on male-flanged adapter (7). Install chains and dust plug (5) and dust cap (6) on female quick-disconnect coupling (4) and male-flanged adapter (7).
11. Install hose assembly (1) to gate valve assembly (2) and position hose assembly (1) in place by pushing in on cam-lever arms (3).

### END OF WORK PACKAGE



**UNIT MAINTENANCE**  
**TANK, FABRIC, COLLAPSIBLE, WATER STORAGE,**  
**20,000 AND 50,000 GALLONS**  
**FILLER/DISCHARGE BALL VALVE**  
**ASSEMBLY (RELIANCE AND MPC MODELS)**  
**REMOVAL, SERVICE, REPAIR AND INSTALLATION**

**INITIAL SETUP****Tools**

Tool Kit, General Mechanics  
 (Item 1, WP 0033 00)

**Mandatory Replacement Parts**

Gasket  
 (Item 1, WP 0041 00)

**Materials/Parts**

Detergent, General Purpose  
 (Item 2, WP 0039 00)  
 Rags, Wiping  
 (Item 4, WP 0039 00)  
 Sealing Compound  
 (Item 5, WP 0039 00)  
 Tape, Anti-seize  
 (Item 7, WP 0039 00)

**REMOVAL**

Remove the ball valve from the filler/discharge hose assembly.

**DISASSEMBLY**

1. Pull cam-lever arms (1) on dust cap (2) out, away from body of dust cap (2).
2. Remove dust cap (2) from male coupling (3). Remove gasket (4) from dust cap (2).
3. Disconnect chain (5) and two key rings (6) from dust cap (2) and male coupling (3).
4. Unthread male coupling (3) from ball valve (7).
5. Pull cam-lever arms (8) on female coupling (9) out, away from body of female coupling (9).
6. Remove dust plug (10) from female coupling (9). Remove gasket (11) from dust plug (10).
7. Disconnect chain (12) and two key rings (13) from dust plug (10) and female coupling (9).
8. Unthread female coupling (9) from ball valve (7).

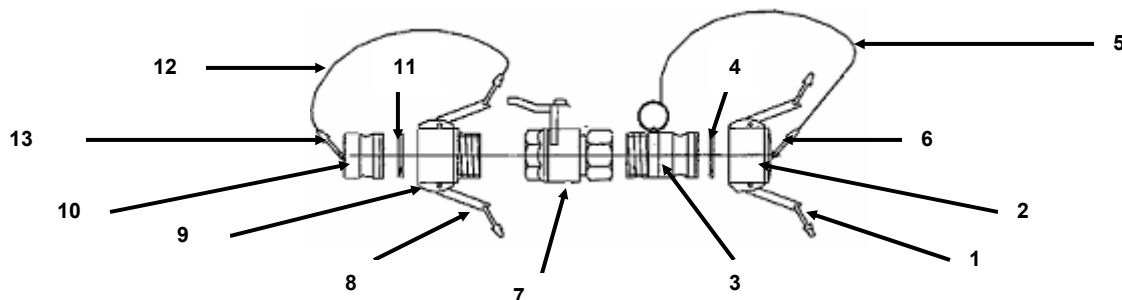

**SERVICE**

1. Clean all parts with detergent and warm water. Dry thoroughly with rags.
2. Inspect all mechanical parts for cracks, dents, breaks, corrosion, and wear. Replace the component if unserviceable.

**ASSEMBLY**

1. Coat threads of female coupling (9) with thread sealing compound or anti-seize tape and install female coupling (9) in ball valve (7).
2. Connect chain (12) and two key rings (13) to dust plug (10) and female coupling (9).
3. Install new gasket (11) on dust plug (10).
4. Push cam-lever arms (8) on female coupling (9) outward, away from body of female coupling (9).
5. Install dust plug (10) in female coupling (9).
6. Push cam-lever arms (8) on female coupling (9) inward toward body of female coupling (9) until locked.
7. Coat threads of male coupling (3) with thread sealing compound or anti-seize tape, and install male coupling (3) in ball valve (7).
8. Connect chain (5) and two key rings (6) to male coupling (3) and dust cap (2).
9. Push cam-lever arms (1) on dust cap (2) outward, away from body of dust cap (2).
10. Install dust cap (2) on male coupling (3).
11. Push cam-lever arms (1) on dust cap (2) inward toward body of dust cap (2) until locked.

**INSTALLATION**

Install the drain ball valve on the drain hose assembly.

**END OF WORK PACKAGE**

**UNIT MAINTENANCE**  
**TANK, FABRIC, COLLAPSIBLE, WATER STORAGE,**  
**20,000 AND 50,000 GALLONS**  
**FILLER/DISCHARGE HOSE ASSEMBLY**  
**REMOVAL, SERVICE AND INSTALLATION**

**INITIAL SETUP****Materials/Parts**

Detergent, General Purpose  
 (Item 2, WP 0039 00)

**Mandatory Replacement Parts**

Gasket  
 (Item 1, WP 0041 00)

**REMOVAL**

1. Pull outward on two cam-lever arms (1). Remove dust cap (2) and dust plug (3) from hose assembly (4).
2. Remove two chain assemblies (5) and remove dust cap (2) and dust plug (3) from hose assembly (4).
3. Remove gasket (6) from dust plug (3).

**SERVICE**

1. Flush out the hose assembly (4) with detergent and hot water.
2. Rinse out the filler/discharge hose assembly (4) thoroughly and air-dry.
3. Inspect the hose for cracks, tears, corrosion, or wear, and ensure that the hose bands are secure to the couplings.
4. Inspect all mechanical parts for cracks, dents, breaks and wear. Replace any unserviceable components.

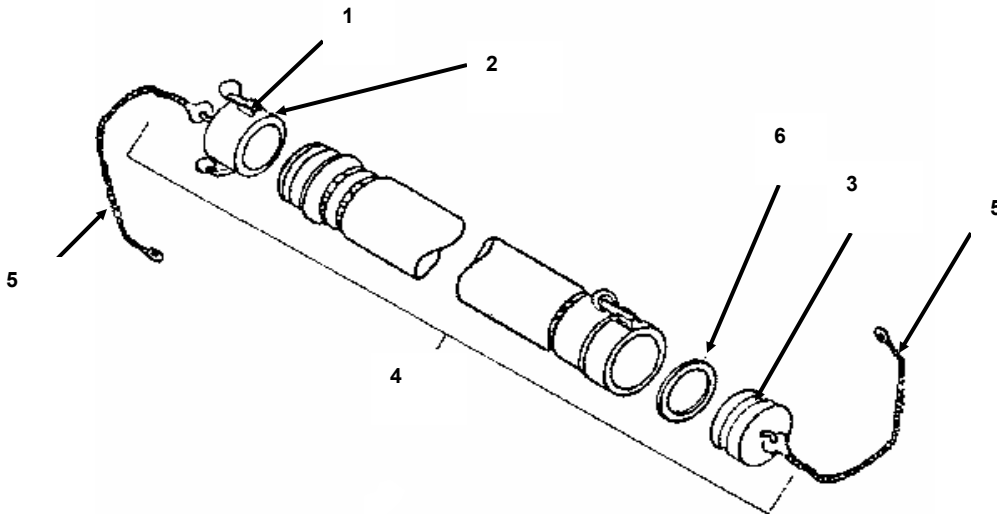

**INSTALLATION**

1. Install two chain assemblies (5), dust cap (2), and dust plug (3) to hose assembly (4). Install new gasket (6) on dust plug (3).
2. Connect dust cap (2) and dust plug (3) to hose assembly (4) by pushing in on cam-lever arms (1).

**END OF WORK PACKAGE**



---

**UNIT MAINTENANCE  
TANK, FABRIC, COLLAPSIBLE, WATER STORAGE,  
20,000 AND 50,000 GALLONS  
DRAIN HOSE ASSEMBLY  
REMOVAL, SERVICE AND INSTALLATION**

---

**INITIAL SETUP****Tools**

Tool Kit, General Mechanics  
(Item 1, WP 0033 00)

**Materials/Parts**

Detergent, General Purpose  
(Item 2, WP 0039 00)  
Rag, Wiping  
(Item 4, WP 0039 00)  
Tape, Anti-seize  
(Item 7, WP 0039 00)

---

**SERVICE**

1. Rotate hose assembly (1) counterclockwise and remove from drain fitting (2).
2. Flush hose assembly (1) with hot, soapy water.
3. Rinse out hose assembly (1) thoroughly and air dry.
4. Clean the threads on threaded quick-disconnect couplings (3) with detergent and hot water. Dry thoroughly with rags.
5. Inspect hose assembly (1) for cracks, tears, or wear.
6. Check and ensure hose bands (4) are secured to threaded quick-disconnect couplings (3).
7. Inspect drain fitting (2) for cracks, damage or missing bolts. If damaged, replace. Replace missing bolts.
8. Apply anti-seize tape on threads of coupling (3). Apply anti-seize tape to hose assembly-threaded fittings.

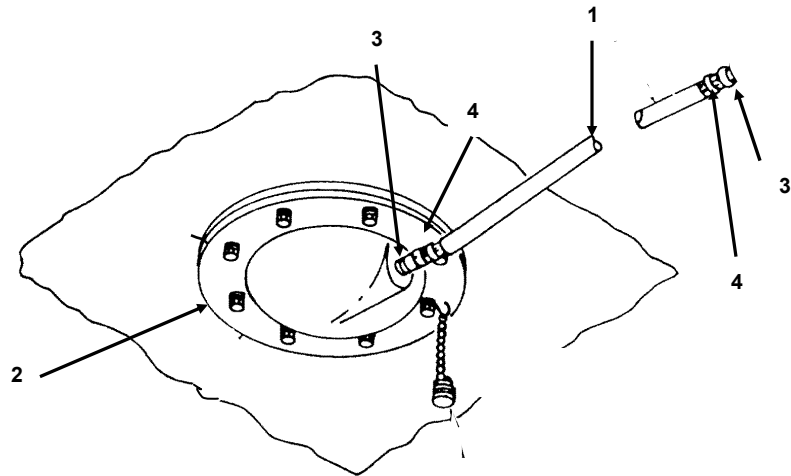

9. Screw hose assembly (1) onto coupling (3).

**END OF WORK PACKAGE**

---

**UNIT MAINTENANCE  
TANK, FABRIC, COLLAPSIBLE, WATER STORAGE  
20,000 AND 50,000 GALLONS  
VENT FITTING ASSEMBLY  
REMOVAL, SERVICE, REPAIR AND INSTALLATION**

---

**INITIAL SETUP****Tools**

Tool Kit, General Mechanics  
(Item 1, WP 0033 00)  
Torque Wrench, (ft-lb)  
(Item 3, WP 0033 00)

**Mandatory Replacement Parts**

Coupling Gasket (2)  
(Item 3, WP 0041 00)  
O-ring Seal (For GTA and Reliance Models only)  
(Item 9, WP 0041 00)

**Materials/Parts**

Detergent, General Purpose  
(Item 2, WP 0039 00)  
Rags, Wiping  
(Item 4, WP 0039 00)  
Silicone Compound  
(Item 6, WP 0039 00)  
Tape, Anti-seize  
(Item 7, WP 0039 00)

---

**REMOVAL****Vent Cap**

1. Unscrew vent cap (1) from vent pipe (2).
2. Remove and discard gasket (3) for GTA Models and Reliance Models only.

**Vent Pipe, Flange and Dust Cap**

1. Open cam lock lever arms (4) outward on coupling (5) to release and remove coupling (5).  
Remove and discard gasket (6).
2. Unscrew coupling (5) from vent pipe (2).

**NOTE**

When bolts are removed, dust cap and chain assembly will be free.

3. Remove eight bolts (7), eight washers (8) and vent pipe flange (9) from tank compression fitting (10).
4. Remove o-ring seal (11) from tank compression fitting (10) and discard.
5. Remove gasket (12) from dust cap (13) and discard.
6. Disconnect chain (14) from key ring (or S-hook).

**SERVICE**

1. Clean vent cap (1) and all components with detergent and water, then rinse thoroughly in clean water and dry with wiping rag.
2. Inspect vent cap (1) for bent or damaged pivot pin. Check for freedom of movement. If damaged, replace vent cap (1).
3. Inspect all parts for cracks, dents, distortion, breaks, wear, or other damage. If any parts are no longer serviceable, replace before performing installation.
4. Inspect bolts (7) for damaged or distorted threads. If damaged, replace bolts (7).
5. Clean o-ring seal groove surface thoroughly with detergent and hot water, for GTA Models and Reliance Models only.

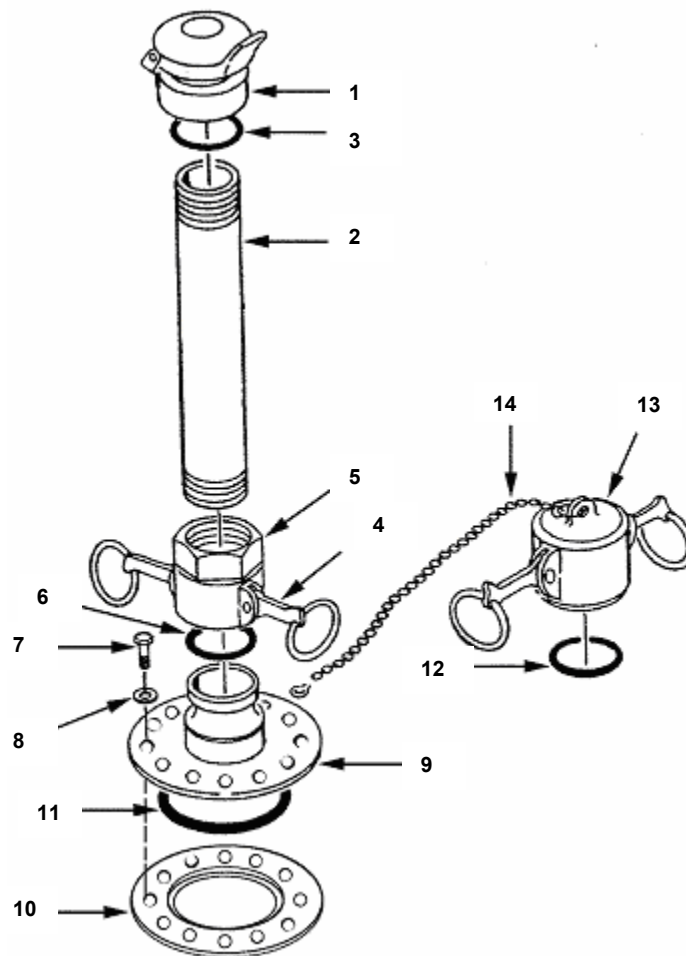

**REPAIR**

Repair is limited to replacement of damaged components.

**INSTALLATION****Vent Pipe, Flange and Dust Cap**

1. Install chain assembly (14) to key ring (or S-hook) on dust cap (13). Install new gasket (12) in dust cap (13).
2. Lubricate new o-ring seal (11) with silicone compound.
3. Position o-ring seal (11) in groove and flanged coupling (9) on water tank compression fitting (10).
4. Make sure o-ring seal (11) is properly seated in groove.

**NOTE**

Loose end of dust cap chain is installed with one of the flange bolts.

5. Install eight bolts (7), eight washers (8) and chain assembly (14).
6. Torque bolts (7) in sequence to 15 ft-lb (20.34 N•m) for Reliance Models or 16 ft-lb (21.70 N•m) for GTA Container and MPC Models.
7. Apply anti-seize tape to threaded ends of vent pipe (2).
8. Screw vent pipe (2) into coupling (5) until hand tight.
9. Install new gasket (6) into coupling (5).
10. Check that cam lever arms (4) of coupling (5) are in the same position as they were during removal and disassembly. Position coupling (5) onto flanged coupling (9).
11. While pushing coupling (5) onto flanged coupling (9), close cam lock lever arms (4).
12. Make sure coupling (5) is securely locked.

**Vent Cap**

1. Install new gasket (3) in vent cap (1), for GTA Models and Reliance Models only.
2. Screw vent cap (1) hand tight on vent pipe (2).

**END OF WORK PACKAGE**



---

**UNIT MAINTENANCE**  
**TANK, FABRIC, COLLAPSIBLE, WATER STORAGE,**  
**20,000 AND 50,000 GALLONS**  
**FILLER/DISCHARGE ASSEMBLY (GTA CONTAINER MODEL)**  
**REMOVAL, SERVICE, REPAIR AND INSTALLATION**

---

**INITIAL SETUP****Tools**

Tool Kit, General Mechanics  
 (Item 1, WP 0033 00)  
 Torque Wrench, (ft-lb)  
 (Item 3, WP 0033 00)

**Materials/Parts**

Detergent, General Purpose  
 (Item 2, WP 0039 00)  
 Rag, Wiping  
 (Item 4, WP 0039 00)  
 Silicone Compound  
 (Item 6, WP 0039 00)  
 Tape, Anti-seize  
 (Item 7, WP 0039 00)

**Equipment Condition**

Filler/Discharge hose assembly removed  
 (WP 0023 00)

**Mandatory Replacement Parts**

Gasket  
 (Item 1, WP 0041 00)  
 Gasket  
 (Item 11, WP 0041 00)  
 Gasket  
 (Item 12, WP 0041 00)  
 Lockwasher  
 (Item 6, WP 0041 00)  
 O-ring Seal  
 (Item 10, WP 0041 00)

---

**DISASSEMBLY****CAUTION**

**Be sure to take off the closure plate before removing the flanged adapter. The flanged adapter is bolted to the closure plate. If the flanged adapter is removed first, the hex head nuts will fall into the tank.**

**NOTE**

The filler/discharge fitting on the discharge end requires a female/male elbow. The filler/discharge fitting on the fill end requires a female/female elbow.

1. Remove 4-inch elbow (1) by pulling outward on cam-lever arms (2), and lifting elbow (1) from flanged adapter (3).
2. Remove and discard elbow gasket (4) from inside elbow (1).
3. Remove twenty screws (5) and washers (6) from closure plate (7). Lift closure plate (7) from tank fitting (8).
4. Remove and discard o-ring (9) from the packing groove located in tank fitting (8).
5. Remove eight nuts (10), lockwashers (11), screws (12), and gaskets (13) from flanged adapter (3), and flanged adapter gasket (14). Discard lockwashers (11), gaskets (13), and gasket (14).
6. Remove and discard gasket (15) from inside dust cap (16).

**SERVICE**

1. Clean all parts with detergent and warm water. Dry thoroughly with rags.
2. Clean packing grooves thoroughly with detergent and hot water.
3. Clean all gasket-sealing surfaces thoroughly with detergent and hot water.
4. Inspect 4-inch elbow (1), flanged adapter (3), and closure plate (7) for cracks, corrosion, scored mating surfaces and broken cam-lever locking arms. Replace components if unserviceable.
5. Inspect dust cap (16) for cracks or missing and broken chain. Inspect screws (5) and (12) for damaged threads. Replace unserviceable parts.

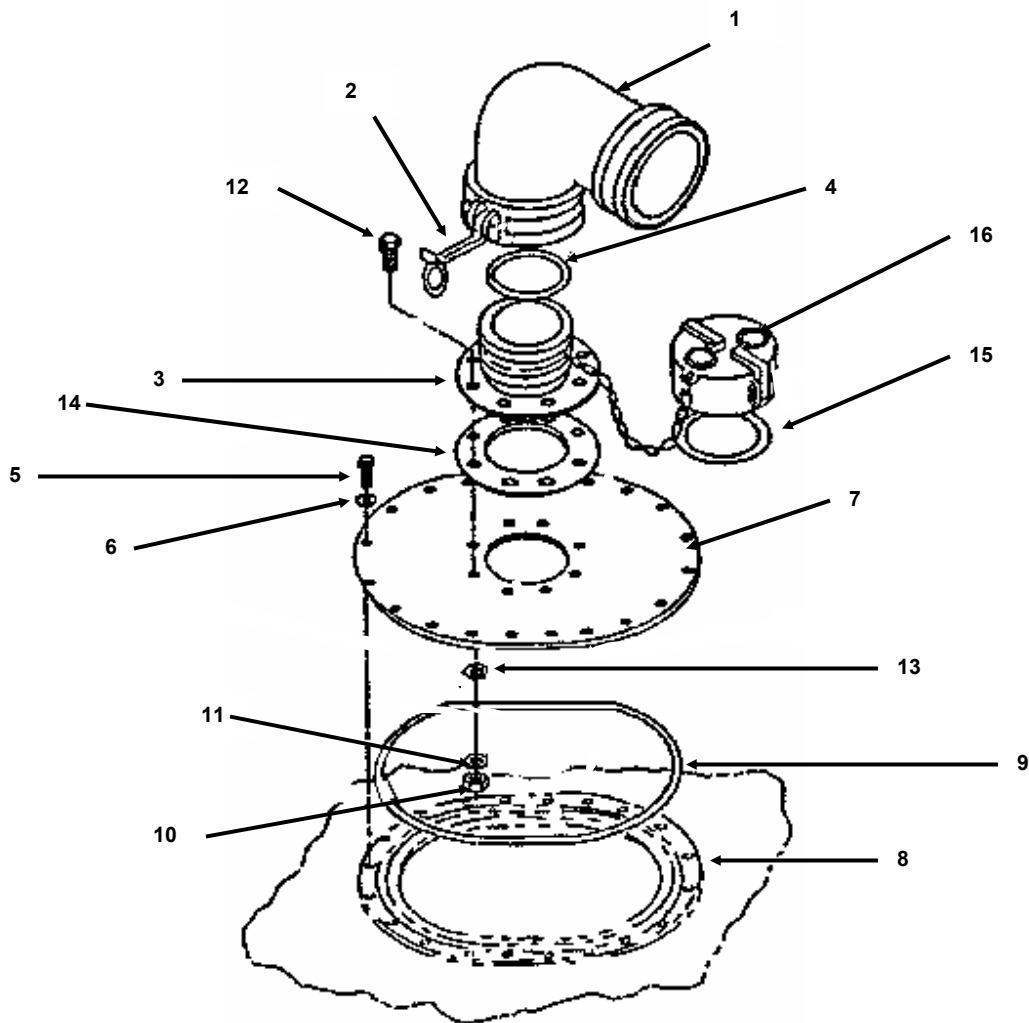



**REPAIR**

Repair is limited to replacement of damaged components.

**ASSEMBLY**

1. Install new gasket (15) into dust cap (16).
2. Install new elbow gasket (4) into elbow (1).
3. Position new flanged adapter gasket (14) on closure plate (7), and align the holes.
4. Position flanged adapter (3) on flanged adapter gasket (14), and align the holes.
5. Install eight screws (12) through the holes in flanged adapter (3), and thread screws (12) through.
6. Assemble new gaskets (13), new lockwashers (11), and nuts (10) to screws (12). Torque the fastening hardware to 16 ft-lbs (21.70 N•m).
7. Lubricate new o-ring seal (9) with silicone compound. Position o-ring seal (9) into packing groove.
8. Install closure plate (7) and attached components through the opening in the tank, until closure plate (7) contacts tank fitting (8).

**NOTE**

If the tank is lying completely flat, lift the tank to the closure plate to begin threading the screws through the tank fitting.

9. Assemble twenty washers (6) onto screws (5). Install screws (5) through closure plate (7) and tank fitting (8).
10. Torque fastening screws (5) to 16 ft-lb (21.70 N•m).
11. Position elbow (1) on flanged adapter (3), and push cam-lever arms (2) inward, locking elbow (1) to flanged adapter (3).

**END OF WORK PACKAGE**



---

**UNIT MAINTENANCE**  
**TANK, FABRIC, COLLAPSIBLE, WATER STORAGE,**  
**20,000 AND 50,000 GALLONS**  
**FILLER/DISCHARGE ASSEMBLY (RELIANCE AND MPC MODELS)**  
**REMOVAL, SERVICE, REPAIR AND INSTALLATION**

---

**INITIAL SETUP****Tools**

Tool Kit General Mechanics  
 (Item 1, WP 0033 00)  
 Torque Wrench (ft-lb)  
 (Item 3, WP 0033 00)

**Materials/Parts**

Detergent, General Purpose  
 (Item 2, WP 0039 00)  
 Rags, Wiping  
 (Item 4, WP 0039 00)  
 Silicone Compound  
 (Item 6, WP 0039 00)

**Equipment Condition**

Filler/Discharge Hose Assembly removed  
 (WP 0023 00)

**Mandatory Replacement Parts**

Gasket  
 (Item 1, WP 0041 00)  
 Gasket  
 (Item 11, WP 0041 00)  
 Gasket  
 (Item 12, WP 0041 00)  
 Lockwasher  
 (Item 6, WP 0041 00)  
 O-Ring  
 (Item 10, WP 0041 00)

**DISASSEMBLY****CAUTION**

**Be sure to take off closure plate before removing the flanged adapter. Flanged adapter is bolted to the closure plate and suction stub. If the flanged adapter is removed first, the hex head nuts bolted to the suction stub will fall into the tank.**

**NOTE**

The filler/discharge fitting on the discharge end requires a female/male elbow. The filler/discharge fitting of the fill end requires a female/female elbow.

1. Remove 4-inch elbow (1) by pulling outward on cam-lever arms (2), and lifting elbow (1) from flanged adapter (3).
2. Remove and discard elbow gasket (4) from inside elbow (1).
3. Remove twenty screws (5) and washers (6) from closure plate (7). Lift closure plate (7) from tank compression fitting (8).
4. Remove and discard o-ring seal (9) from the packing groove located in tank fitting (8).

**NOTE**

MPC Model Tanks use an additional eight gaskets on the screws for mounting the suction stub.

5. Remove eight nuts (10), lockwashers (11), screws (12), and gaskets (13) from suction stub (14), flanged adapter (3), and gasket (15). Discard lockwashers (11), gaskets (13), and gasket (15).
6. Remove and discard gasket (16) from inside dust cap (17).

**SERVICE**

1. Clean all parts with detergent and warm water. Dry thoroughly with rags.
2. Clean packing grooves thoroughly with detergent and hot water.
3. Clean all gasket-sealing surfaces thoroughly with detergent and hot water.
4. Inspect 4-inch elbow (1), flanged adapter (3), closure plate (7), and suction stub (14) for cracks, corrosion, dents, breaks, wear, and broken cam-lever locking arms. Replace components if unserviceable.
5. Inspect dust cap (17) for cracks, missing or broken chain. Inspect screws (5) and (12) for damaged threads. Replace unserviceable parts.

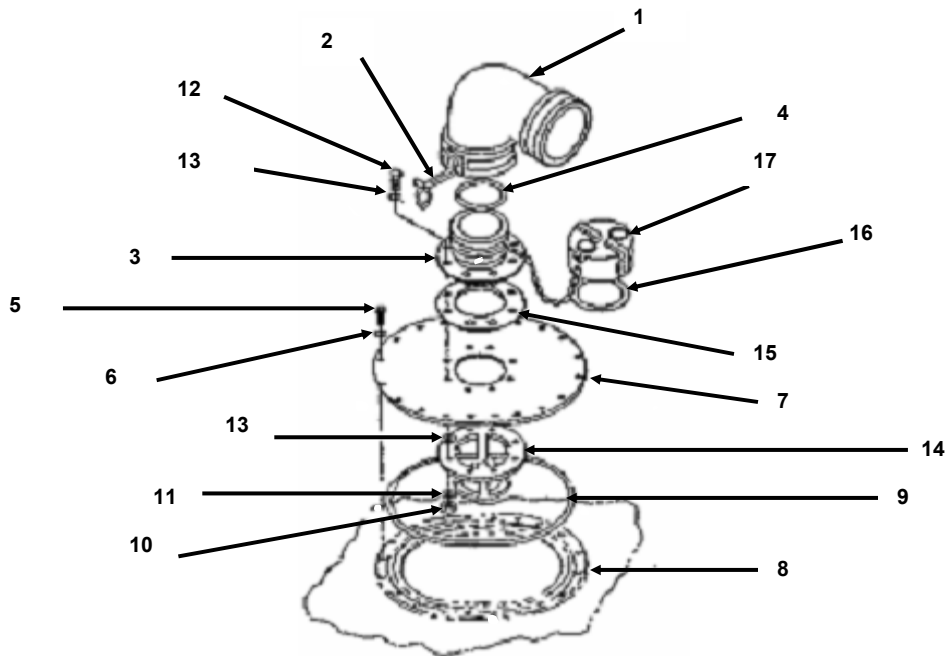

**REPAIR**

Repair is limited to replacement of damaged components.

**ASSEMBLY**

1. Install new gasket (16) into dust cap (17).
2. Install new elbow gasket (4) into elbow (1).
3. Place suction stub (14) on a hard, flat surface with the eight bolt holes positioned up.
4. Position new gaskets (13) over each bolt hole in suction stub (14).
5. Position closure plate (7) on top of new gaskets (13), and align holes.
6. Position new flanged adapter gasket (15) on closure plate (7), and align the holes.
7. Position flanged adapter (3) on gasket (15), and align the holes.
8. Install screws (12) and new gaskets (13) (if required) through the holes in flanged adapter (3), and thread screws (12) through until the ends protrude through suction stub (14).

**NOTE**

MPC Model Tanks use an additional eight gaskets on the screws for mounting the suction stub.

9. Assemble new gaskets (13), new lockwashers (11), and nuts (10) to screws (12). Torque the fastening hardware to 15 ft-lb (20.34 N•m) for Reliance Models, or 16 ft-lb (21.70 N•m) for MPC Models.
10. Lubricate new o-ring seal (9) with silicone compound. Position o-ring (9) into the packing groove.
11. Install closure plate (7) and attached components through the opening in the tank, until closure plate (7) contacts the tank fitting (8).

**NOTE**

If the tank is lying completely flat, lift the tank to the closure plate to begin threading the screws through the tank fitting.

12. Assemble twenty washers (6) onto screws (5). Install screws (5) through closure plate (7) and tank fitting (8).
13. Torque fastening screws (5) to 15 ft-lb (20.34 N•m) for Reliance Models, or 16 ft-lb (21.70 N•m) for MPC Models.
14. Position elbow (1) on flanged adapter (3), and push cam-lever arms (2) inward, locking elbow (1) to flanged adapter (3).

**END OF WORK PACKAGE**



---

**UNIT MAINTENANCE  
TANK, FABRIC, COLLAPSIBLE, WATER STORAGE,  
20,000 AND 50,000 GALLONS  
DRAIN FITTING ASSEMBLY  
SERVICE AND REPAIR**

---

**INITIAL SETUP****Tools**

Tool Kit, General Mechanics  
(Item 1, WP 0033 00)  
Torque Wrench, (ft-lb)  
(Item 3, WP 0033 00)

**Equipment Condition**

Tank drain hose assembly removed  
(WP 0024 00)

**Materials/Parts**

Detergent, General Purpose  
(Item 2, WP 0039 00)  
Rags, Wiping  
(Item 4, WP 0039 00)  
Silicone Compound  
(Item 6, WP 0039 00)  
Tape, Anti-seize  
(Item 7, WP 0039 00)

**Mandatory Replacement Parts**

O-ring seal  
(Item 9, WP 0041 00)

---

**DISASSEMBLY**

1. Remove S-hook (or key ring) of chain assembly (1) from bracket (2). Remove drain plug screw (3), bracket (2), and drain plug (4) from drain cover plate (5).
2. Disconnect S-hook (or key ring) on other end of chain assembly (1) from bracket (6). Remove eight bolts (7), bracket (6), and washers (8) from drain cover plate (5) and tank compression fitting (9).
3. Remove drain cover plate (5).
4. Remove o-ring (10) from tank compression fitting (9). Discard o-ring (10).

**SERVICE**

1. Clean all parts with detergent and water, rinse thoroughly, then dry with rags.
2. Clean o-ring seal groove surface thoroughly with detergent and hot water.
3. Inspect drain plug (4) for cracks or breaks. If damaged, replace plug (4).
4. Inspect drain cover plate (5) for cracks or other damage. If damaged, replace drain cover plate (5).
5. Inspect drain plug screw (3) for distortion or damaged threads. If damaged, replace plug screw (3).
6. Inspect chain (1), S-hook (or key ring), and brackets (2) and (6) for cracks, distortion or other damage. If damaged, replace chain (1), S-hook (or key ring), and brackets (2) and (6).
7. Inspect bolts (7) for damaged threads. If threads are damaged, replace bolts (7).

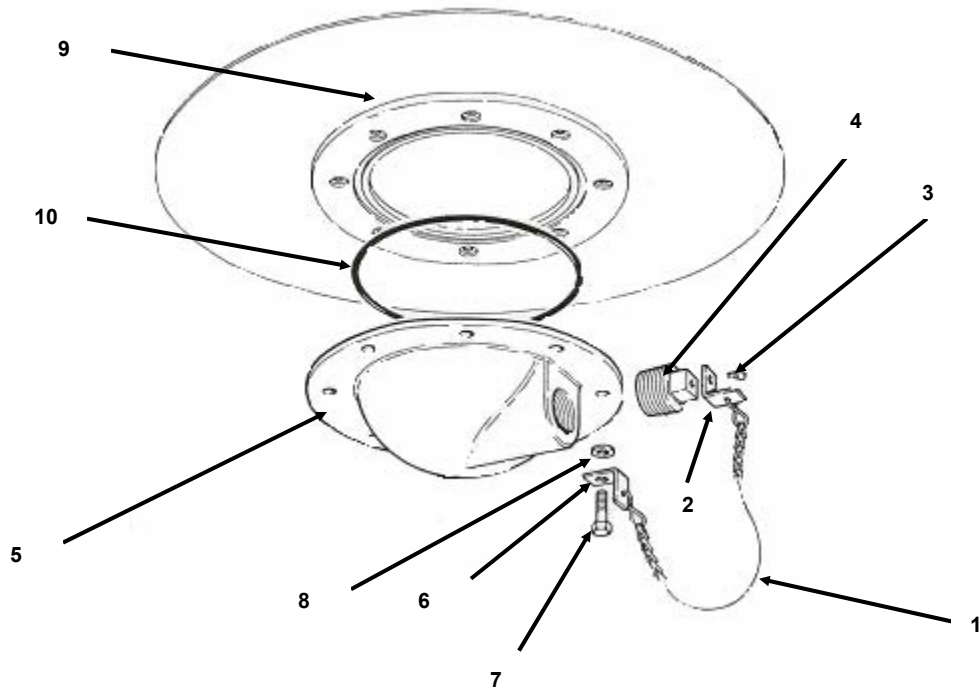

## REPAIR

Repair is limited to replacement of damaged components.

## ASSEMBLY

1. Lubricate new o-ring (10) with silicone compound. Position o-ring (10) into packing groove located on tank compression fitting (9).
2. Position drain cover plate (5) on the tank compression fitting (9). Align drain cover plate (5) towards nearest tank edge and align fastening holes.
3. Install drain cover plate (5) and bracket (6) to the tank fitting with eight bolts (7) and washers (8), by hand-tightening bolts (7).
4. Attach S-hook (or key ring) of chain assembly (1) to bracket (6). Torque all bolts (7) in sequence to 15 ft-lb (20.34 N•m) for Reliance Models, or 16 ft-lb (21.70 N•m) for GTA Container Models and MPC Models.
5. Apply anti-seize tape to drain plug screw (3) threads.
6. Install drain plug (4), drain plug screw (3), and bracket (2) to drain cover plate (5).
7. Connect S-hook (or key ring) to the remaining end of chain assembly (1).
8. Attach S-hook of chain assembly (1) to bracket (2).

## END OF WORK PACKAGE



---

**UNIT MAINTENANCE  
TANK, FABRIC, COLLAPSIBLE, WATER STORAGE  
20,000 AND 50,000 GALLONS  
GROUND CLOTH MAINTENANCE**

---

**GROUND CLOTH MAINTENANCE**

Unit maintenance on the ground cloth is limited to replacement. The ground cloth must be replaced when badly torn, frayed or it contains many large punctures.

**END OF WORK PACKAGE**



---

**UNIT MAINTENANCE  
TANK, FABRIC, COLLAPSIBLE, WATER STORAGE  
20,000 AND 50,000 GALLONS  
EMERGENCY REPAIR KIT MAINTENANCE**

---

**EMERGENCY REPAIR KIT MAINTENANCE**

Unit maintenance on the repair kit is limited to replacement of missing or damaged components. Inspect sealing clamps for missing plates, gaskets, wing nuts and bent or stripped threaded rods. Inventory the repair kit to determine if parts are missing.

**END OF WORK PACKAGE**



---

**OPERATOR AND UNIT MAINTENANCE MANUAL  
(INCLUDING REPAIR PARTS AND SPECIAL TOOLS LIST)  
TANK, FABRIC, COLLAPSIBLE, WATER STORAGE,  
20,000 AND 50,000 GALLONS  
PREPARATION FOR STORAGE OR SHIPMENT**

---

## PREPARATION FOR STORAGE OR SHIPMENT

### CAUTION

**Always handle the tank carefully. Pad the components stored with the tank to avoid chafing during storage or transportation. Rough handling or careless storage can damage the tank.**

### NOTE

Prior to storage, the tank should be disassembled, cleaned, and preserved with all its components for future use.

1. Drain all water from tank (WP 0005 00).

### CAUTION

**Make sure tank is completely dry before storing. Water will create mildew, decreasing the life of the tank if it is not completely dry.**

2. Remove the tank drain hose assembly from the tank drain fitting and install the drain plug (WP 0024 00).
3. Remove the filler/discharge elbows from the filler/discharge adapters (WP 0026 00 or WP 0027 00).
4. Remove the vent fitting assembly from the flanged adapter, and install the dust cap (WP 0025 00).
5. Remove the filler/discharge assembly from the tank (WP 0026 00 or WP 0027 00).
6. Flush the tank with detergent solution.

### NOTE

Contact unit/local safety office for disposal of water tank cleaning residue.

7. Drain the detergent solution from the tank.
8. Flush the tank with clear water.
9. Dry tank thoroughly until all moisture has evaporated.
10. Install the filler/discharge assembly on the tank (WP 0026 00 or WP 0027 00).
11. Install the dust caps on the flanged adapters of the filler/discharge assemblies.
12. Brush off all debris clinging to the fabric material of the tank.

---

**CRATING INSTRUCTIONS**

1. Make sure tank has been properly folded (WP 0005 00).

**CAUTION**

**Use care when packing tank. The tank will be easily damaged by tools, packing box nails or other sharp objects.**

2. Pack the tank in a close fitting box, crate, or other type of container. When tank is disassembled and refolded, it is to be replaced in the original box, crate or container.
3. Each tank is provided with suitable packing around the tank to prevent the tank fabric from being damaged by contact with the inside of the box or container. When tank is replaced in the original box, crate or other type of container, the packing material is replaced around the tank in the same manner as when received.

**ADMINISTRATIVE STORAGE**

1. Placement of equipment in administrative storage should be for short periods of time when a shortage of maintenance effort exists. Items should be in mission readiness within 24 hours or within the time factors determined by the directing authority. During the storage period, appropriate maintenance records will be kept.
2. Before placing the equipment in administrative storage, current preventative maintenance checks and services should be completed, shortcomings and deficiencies should be corrected and all Modification Work Orders (MWOs) should be applied.
3. Inside storage is preferred for items selected for administrative storage. If inside storage is not available, trucks, vans, conex containers and other containers may be used. Refer to WP 0002 00 for ambient storage temperature range.

**END OF WORK PACKAGE**

**CHAPTER 6**

**SUPPORTING INFORMATION**  
**FOR**  
**TANK, FABRIC, COLLAPSIBLE, WATER STORAGE,**  
**20,000 and 50,000 GALLONS**





---

**OPERATOR AND UNIT MAINTENANCE  
(INCLUDING REPAIR PARTS AND SPECIAL TOOLS LIST)  
TANK, FABRIC, COLLAPSIBLE, WATER STORAGE,  
20,000 AND 50,000 GALLONS  
REFERENCES**

---

**REFERENCES**

This work package lists all forms, field manuals, technical manuals and miscellaneous publications referenced in this manual.

**TECHNICAL MANUALS**

AR 700-138	Army Logistics Readiness and Sustainability
AR 750-1	Army Materiel Maintenance Policy and Retail Maintenance Operations
DA PAM 738-750	Functional Users Manual for The Army Maintenance Management System (TAMMS)
DA PAM 738-751	Functional Users Manual for The Army Maintenance Management System Aviation (TAMMS-A)
TM 740-90-1	Administrative Storage of Equipment
TM 750-244-3	Procedures for Destruction of Equipment to Prevent Enemy Use
TM 4700-15/1	Equipment Record Procedures
TM 10-4610-234-13	Operator, Unit and Direct Support Maintenance Manual for 40,000 Gallon Water Distribution System

**FORMS**

DA Form 2028	Recommended Changes to Publications and Blank Forms
DA Form 2404	Equipment Inspection and Maintenance Worksheet
DA Form 2407	Maintenance Request
SF 364	Report of Discrepancy
SF 368	Product Quality Deficiency Report

**FIELD MANUALS**

FM 3-3, FM 3-4, FM 3-5	Detailed Decontamination Procedures
FM 21-11	First Aid

**MISCELLANEOUS**

CTA 8-100	Army Medical Dept. Expendable/Durable Items
CTA 50-790	Expendable/Durable Items (except medical, Class V repair parts, and heraldic items)

**END OF WORK PACKAGE**



---

**OPERATOR AND UNIT MAINTENANCE  
(INCLUDING REPAIR PARTS AND SPECIAL TOOLS LIST)  
TANK, FABRIC, COLLAPSIBLE, WATER STORAGE,  
20,000 AND 50,000 GALLONS  
MAINTENANCE ALLOCATION CHART**

---

## MAINTENANCE ALLOCATION CHART (MAC)

### INTRODUCTION

#### The Army Maintenance System MAC

This introduction provides a general explanation of all maintenance and repair functions authorized at various maintenance levels under the standard Army Maintenance System concept.

The MAC (immediately following the introduction) designates overall authority and responsibility for the performance of maintenance functions on the identified end item or component. The application of the maintenance functions to the end item or component shall be consistent with the capacities and capabilities of the designated maintenance levels, which are shown on the MAC in column (4) as:

Unit – includes two subcolumns, C (operator/crew) and O (unit) maintenance.

Direct Support – includes an F subcolumn.

General Support – includes an H subcolumn.

Depot – includes a D subcolumn.

The tools and test equipment requirements (immediately following the MAC) list the tools and test equipment (both special tools and common tool sets) required for each maintenance function as referenced from the MAC.

The remarks (immediately following the tools and test equipment requirements) contain supplemental instructions and explanatory notes for a particular maintenance function.

### Maintenance Functions

Maintenance functions are limited to and defined as follows:

1. Inspect. To determine the serviceability of an item by comparing its physical, mechanical, and/or electrical characteristics with established standards through examination; e.g., by sight, sound, or feel.
2. Test. To verify serviceability by measuring the mechanical, pneumatic, hydraulic, or electrical characteristics of an item and comparing those characteristics with prescribed standards on a scheduled basis.
3. Service. Operations required periodically to keep an item in proper operating condition; e.g., to clean (includes decontaminate, when required), to preserve, to drain, to paint, or to replenish fuel, lubricants, hydraulic fluids, or gases.
4. Adjust. To maintain or regulate, within prescribed limits, by bringing into proper position, or by setting the operating characteristics to specified parameters.
5. Align. To adjust specified variable elements of an item to bring out optimum or desired performance.

6. Calibrate. To determine and cause corrections to be made or to be adjusted on instruments of test, measuring, and diagnostic equipment used in precision measurement. Consists of comparisons of two instruments, one of which is a certified standard of known accuracy, to detect and adjust any discrepancy in the accuracy of the instrument being compared.
7. Remove/Install. To remove and install the same item when required to perform service or other maintenance functions. Install may be the act of emplacing, seating, or fixing into position a spare, repair part, or module (component or assembly) in a manner to allow the proper functioning of an equipment or system.
8. Replace. To remove an unserviceable item and install a serviceable counterpart in its place. "Replace" is authorized by the MAC and assigned maintenance level is shown as the third position code of the Source, Maintenance and Recoverability (SMR) code.
9. Repair. The application of maintenance services, including fault location/troubleshooting, removal/installation, disassembly/assembly procedures, and maintenance actions to identify troubles and restore serviceability to an item by correcting specific damage, fault, malfunction, or failure in a part, subassembly, module (component or assembly), end item, or system.

#### NOTE

The following definitions are applicable to the "Repair" maintenance function:

Services – Inspect, test, service, adjust, align, calibrate, and/or replace.

Fault location/troubleshooting – The process of investigating and detecting the cause of equipment malfunctioning; the act of isolating a fault within a system or Unit Under Test (UUT).

Disassembly/assembly – The step-by-step breakdown (taking apart) of a spare/functional group coded item to the level of its least component that is assigned an SMR code for the level of maintenance under consideration (i.e., identified as maintenance significant).

Actions – Welding, grinding, riveting, straightening, facing, machining, and/or resurfacing.

10. Overhaul. That maintenance effort (service/action) prescribed to restore an item to a completely serviceable/operational condition as required by maintenance standards in appropriate technical publications. Overhaul is normally the highest degree of maintenance performed by the Army. Overhaul does not normally return an item to like new condition.
11. Rebuild. Consists of those services/actions necessary for the restoration of unserviceable equipment to a like new condition in accordance with original manufacturing standards. Rebuild is the highest degree of material maintenance applied to Army equipment. The rebuild operation includes the act of returning to zero those age measurements (e.g., hours/miles) considered in classifying Army equipment/components.

#### Explanation of Columns in the MAC

Column (1) – Group Number. Column (1) lists functional group code (FGC) numbers, the purpose of which is to identify maintenance significant components, assemblies, subassemblies, and modules with the Next Higher Assembly (NHA). End item group number shall be "00."

Column (2) – Component/Assembly. Column (2) contains the item names of components, assemblies, subassemblies, and modules for which maintenance is authorized.

Column (3) – Maintenance Function. Column (3) lists the functions to be performed on the item listed in column (2). (For a detailed explanation of these functions refer to “Maintenance Functions” outlined above.)

Column (4) – Maintenance Level. Column (4) specifies each level of maintenance authorized to perform each function listed in column (3), by indicating work time required (expressed as man-hours in whole hours or decimals) in the appropriate sub-column. This work time figure represents the active time required to perform that maintenance function at the indicated level of maintenance. If the number or complexity of the tasks within the listed maintenance function varies at different maintenance levels, appropriate work time figures are to be shown for each level. The work time figure represents the average time required to restore an item (assembly, subassembly, component, module, end item, or system) to a serviceable condition under typical field operating conditions. This time includes preparation time (including any necessary disassembly/assembly time), troubleshooting/fault location time, and quality assurance time in addition to the time required to perform the specific tasks identified for the maintenance functions authorized in the MAC. The symbol designations for the various maintenance levels are as follows:

- C – Operator or crew maintenance
- O – Unit maintenance
- F – Direct support maintenance
- L – Specialized repair activity (SRA)
- H – General support maintenance
- D – Depot maintenance

#### NOTE

The “L” maintenance level is not included in column (4) of the MAC. Functions to this level of maintenance are identified by a work time figure in the “H” column of column (4), and an associated reference code is used in the REMARKS column (6). This code is keyed to the remarks and the SRA complete repair application is explained there.

Column (5) – Tools and Test Equipment Reference Code. Column (5) specifies, by code, those common tool sets (not individual tools), common Test, Measurement and Diagnostic Equipment (TMDE), and special tools, special TMDE and special support equipment required to perform the designated function. Codes are keyed to the entries in the tools and test equipment table.

Column (6) – Remarks Code. When applicable this column contains a letter code, in alphabetical order, which is keyed to the remarks table entries.

#### Explanation of Columns in the Tool and Test Equipment Requirements

Column (1) – Tool or Test Equipment Reference Code. The tool or test equipment reference code correlates with a code used in column (5) of the MAC.

Column (2) – Maintenance Level. The lowest level of maintenance authorized to use the tool or test equipment.

Column (3) – Nomenclature. Name or identification of the tool or test equipment.

Column (4) – National Stock Number (NSN). The NSN of the tool or test equipment.

Column (5) – Tool Number. The manufacturer’s part number, model number, or type number.

**Explanation of Columns in the Remarks**

Column (1) – Remarks Code. The code recorded in column (6) of the MAC.

Column (2) – Remarks. This column lists information pertinent to the maintenance function being performed as indicated in the MAC.

Table 1. MAC for Tank, Collapsible, Water Storage, 20,000 and 50,000 Gallons.

(1) GROUP NUMBER	(2) COMPONENT/ ASSEMBLY	(3) MAINTENANCE FUNCTION	(4) MAINTENANCE LEVEL					(5) TOOLS AND TEST EQUIPMENT REF CODE	(6) REMARKS CODE
			UNIT		DS	GS	DEPOT		
			C	O	F	H	D		
00	TANK ASSEMBLY	Inspect	0.7						
		Replace		2.5				1, 2	
		Repair	0.5	4.0				1, 2	A, B
01	TANK ENVELOPE	Inspect	0.2	0.2				1	
		Replace		1.0					
		Repair	0.5					2, 3	B
02	VENT FITTING ASSEMBLY	Inspect	0.2	0.2					
		Replace		0.5					
		Repair		1.0				1, 2	B
03	FILLER/ DISCHARGE ASSEMBLIES	Inspect	0.2	0.2					
		Replace		0.7				1	
		Repair		1.0				1, 2	B
04	DRAIN FITTING ASSEMBLY	Inspect	0.2	0.2					
		Replace		0.5				1, 2	
		Repair		0.5				1	B
05	DRAIN HOSE ASSEMBLY & BALL VALVE, 2 INCH	Inspect	0.2	0.2				1	
		Replace		0.2				1, 2	
		Repair	0.1	0.5				1, 2	B
06	GATE/BALL VALVE, 4 INCH	Inspect	0.2	0.2				1	
		Replace		0.2				1	
		Repair	0.1	1.0				1, 2	
07	FILLER/ DISCHARGE HOSE ASSEMBLY, 4 INCH	Inspect	0.2	0.2					
		Replace		0.2					
		Repair	0.1	0.5					
08	GROUND CLOTH	Inspect Replace	0.1	0.1					
09	EMERGENCY REPAIR ITEMS	Inspect Replace	0.1	0.1					C

**Table 2. Tools and Test Equipment Requirements for Tank, Collapsible, Water Storage, 20,000 and 50,000 Gallons.**

TOOL OR TEST EQUIPMENT REF. CODE	MAINTENANCE LEVEL	NOMENCLATURE	NATIONAL STOCK NUMBER	TOOL NUMBER
1	O	Tool Kit, General Mechanics; Automotive	5180-00-177-7033	(50980) SC-5180-90-CL-N26
2	O	Torque Wrench (inch-pounds)	5120-01-075-2597	(80204) B107.14M TY1CLBST3
3	O	Torque Wrench (foot-pounds)	5120-00-242-3264	(80204) B107.14M

**Table 3. Remarks for Tank, Collapsible, Water Storage, 20,000 and 50,000 Gallons.**

REMARKS CODE	REMARKS
A	Operator inspection occurs with assembly intact. Unit level inspection occurs after the assembly has been disassembled and cleaned.
B	Operator repair is limited to replacement of gaskets on quick-disconnect couplings.
C	Operator repair is limited to use of the clamps and plugs included with the emergency repair items.

**END OF WORK PACKAGE**



---

**OPERATOR AND UNIT MAINTENANCE  
(INCLUDING REPAIR PARTS AND SPECIAL TOOLS LIST)  
TANK, FABRIC, COLLAPSIBLE, WATER STORAGE,  
20,000 AND 50,000 GALLONS  
REPAIR PARTS AND SPECIAL TOOLS LIST INTRODUCTION**

---

**INTRODUCTION****SCOPE**

This RPSTL lists and authorizes spares and repair parts; special tools; special test, measurement, and diagnostic equipment (TMDE); and other special support equipment required for performance of unit maintenance of the collapsible fabric water storage tank. It authorizes the requisitioning, issue, and disposition of spares, repair parts, and special tools as indicated by the source, maintenance, and recoverability (SMR) codes.

**GENERAL**

In addition to the Introduction work package, this RPSTL is divided into the following work packages.

1. Repair Parts List Work Packages. Work packages containing lists of spares and repair parts authorized by this RPSTL for use in the performance of maintenance. These work packages also include parts which must be removed for replacement of the authorized parts. Parts lists are composed of functional groups in ascending alphanumeric sequence, with the parts in each group listed in ascending figure and item number sequence. Sending units, brackets, filters, and bolts are listed with the component they mount on. Bulk materials are listed by item name in FIG. BULK at the end of the work packages. Repair parts kits are listed separately in their own functional group and work package. Repair parts for reparable special tools are also listed in a separate work package. Items listed are shown on the associated illustrations.
2. Special Tools List Work Packages. Work packages containing lists of special tools, special TMDE, and special support equipment authorized by this RPSTL (as indicated by Basis of Issue (BOI) information in the DESCRIPTION AND USABLE ON CODE (UOC) column). Tools that are components of common tool sets and/or Class VII are not listed.
3. Cross-Reference Index Work Packages. There are two cross-reference index work packages in this RPSTL: the National Stock Number (NSN) Index work package and the Part Number (P/N) Index work package. The National Stock Number Index work package refers you to the figure and item number. The Part Number Index work package refers you to the figure and item number.

**EXPLANATION OF COLUMNS IN THE REPAIR PARTS LIST AND SPECIAL TOOLS LIST WORK PACKAGES**

ITEM NO. (Column (1)). Indicates the number used to identify items called out in the illustration.

SMR CODE (Column (2)). The SMR code containing supply/requisitioning information, maintenance level authorization criteria, and disposition instruction, as shown in the following breakout:

<u>Source Code</u>	<u>Maintenance Code</u>	<u>Recoverability Code</u>
<u>xx</u>	<u>xx</u>	<u>xx</u>
1 <sup>st</sup> two positions: How to get an item.	3 <sup>rd</sup> position: Who can install, replace, or use the item.	4 <sup>th</sup> position: Who can do complete repair* on the item.
		5 <sup>th</sup> position: Who determines disposition action on unserviceable items.

\*Complete Repair: Maintenance capacity, capability, and authority to perform all corrective maintenance tasks of the "Repair" function in a use/user environment in order to restore serviceability to a failed item.

Source Code. The source code tells you how you get an item needed for maintenance, repair, or overhaul of an end item/equipment. Explanations of source codes follow:

**Source Code****Application/Explanation**

PA  
PB  
PC  
PD  
PE  
PF  
PG

Stock items; use the applicable NSN to requisition/request items with these source codes. They are authorized to the level indicated by the code entered in the 3<sup>rd</sup> position of the SMR code.

**NOTE**

Items coded PC are subject to deterioration.

KD  
KF  
KB

Item with these codes are not to be requested/requisitioned individually. They are part of a kit which is authorized to the maintenance level indicated in the 3<sup>rd</sup> position of the SMR code. The complete kit must be requisitioned and applied.

MO – Made at unit/AVUM level  
MF – Made at DS/AVIM level  
MH – Made at GS level  
ML – Made at SRA  
MD – Made at depot

Items with these codes are not to be requisitioned/requested individually. They must be made from bulk material which is identified by the P/N in the DESCRIPTION AND USABLE ON CODE (UOC) column and listed in the bulk material group work package of the RPSTL. If the item is authorized to you by the 3<sup>rd</sup> position code of the SMR code, but the source code indicates it is made at higher level, order the item from the higher level of maintenance.

AO – Assembled by unit/AVUM level  
AF – Assembled by DS/AVIM level  
AH – Assembled by GS level  
AL – Assembled by SRA  
AD – Assembled by depot

Items with these codes are not to be requested/requisitioned individually. The parts that make up the assembled item must be requisitioned or fabricated and assembled at the level of maintenance indicated by the source code. If the 3<sup>rd</sup> position of the SMR code authorizes you to replace the item, but the source code indicates the item is assembled at a higher level, order the item from the higher level of maintenance.

XA

Do not requisition an "XA" coded item. Order the next higher assembly. (Refer to the NOTE below.)

XB

If an item is not available from salvage, order it using the CAGEC and P/N.

XC

Installation drawings, diagrams, instruction sheets, field service drawings; identified by manufacturer's P/N.

XD

Item is not stocked. Order an XD-coded item through normal supply channels using the CAGEC and P/N given, if no NSN is available.

**NOTE**

Cannibalization or controlled exchange, when authorized, may be used as a source of supply for items with the above source codes except for those items source coded "XA" or those aircraft support items restricted by requirements of AR 750-1.

Maintenance Code. Maintenance codes tell you the level(s) of maintenance authorized to use and repair support items. The maintenance codes are entered in the third and fourth positions of the SMR code as follows:

Third position. The maintenance code entered in the third position tells you the lowest maintenance level authorized to remove, replace, and use an item. The maintenance code entered in the third position will indicate authorization to the following levels of maintenance:

<b><u>Maintenance Code</u></b>	<b><u>Application/Explanation</u></b>
C –	Crew or operator maintenance done within unit/AVUM maintenance.
O –	Unit level/AVUM maintenance can remove, replace, and use the item.
F –	Direct support/AVIM maintenance can remove, replace, and use the item.
H –	General support maintenance can remove, replace, and use the item.
L –	Specialized repair activity can remove, replace, and use the item.
D –	Depot can remove, replace, and use the item.

Fourth position. The maintenance code entered in the fourth position tells you whether or not the item is to be repaired and identifies the lowest maintenance level with the capability to do complete repair (perform all authorized repair functions).

**NOTE**

Some limited repair may be done on the item at a lower level of maintenance, if authorized by the Maintenance Allocation Chart (MAC) and SMR codes.

<b><u>Maintenance Code</u></b>	<b><u>Application/Explanation</u></b>
O –	Unit/AVUM is the lowest level that can do complete repair of the item.
F –	Direct support/AVIM is the lowest level that can do complete repair of the item.
H –	General support is the lowest level that can do complete repair of the item.
L –	Specialized repair activity is the lowest level that can do complete repair of the item.
D –	Depot is the lowest level that can do complete repair of the item.
Z –	Nonreparable. No repair is authorized.
B –	No repair is authorized. No parts or special tools are authorized for maintenance of "B" coded item. However, the item may be reconditioned by adjusting, lubricating, etc., at the user level.

Recoverability Code. Recoverability codes are assigned to items to indicate the disposition action on unserviceable items. The recoverability code is shown in the fifth position of the SMR code as follows:

<u>Recoverability Code</u>	<u>Application/Explanation</u>
Z –	Nonreparable item. When unserviceable, condemn and dispose of the item at the level of maintenance shown in the third position of the SMR Code.
O –	Reparable item. When uneconomically reparable, condemn and dispose of the item at the unit level.
F –	Reparable item. When uneconomically reparable, condemn and dispose of the item at the direct support level.
H –	Reparable item. When uneconomically reparable, condemn and dispose of the item at the general support level.
D –	Reparable item. When beyond lower level repair capability, return to depot. Condemnation and disposal of item are not authorized below depot level.
L –	Reparable item. Condemnation and disposal not authorized below Specialized Repair Activity (SRA).
A –	Item requires special handling or condemnation procedures because of specific reasons (such as precious metal content, high dollar value, critical material, or hazardous material). Refer to appropriate manuals/directives for specific instructions.

NSN (Column (3)). The NSN for the item is listed in this column.

CAGEC (Column (4)). The Commercial and Government Entity Code (CAGEC) is a five-digit code which is used to identify the manufacturer, distributor, or Government agency/activity that supplies the item.

PART NUMBER (Column (5)). Indicates the primary number used by the manufacturer (individual, company, firm, corporation, or Government activity), which controls the design and characteristics of the item by means of its engineering drawings, specifications, standards, and inspection requirements to identify an item or range of items.

#### NOTE

When you use an NSN to requisition an item, the item you receive may have a different P/N from the number listed.

DESCRIPTION AND USABLE ON CODE (UOC) (Column (6)). This column includes the following information:

1. The federal item name, and when required, a minimum description to identify the item.
2. P/Ns of bulk materials are referenced in this column in the line entry to be manufactured or fabricated.
3. Hardness Critical Item (HCI). A support item that provides the equipment with special protection from electromagnetic pulse (EMP) damage during a nuclear attack.
4. The statement END OF FIGURE appears just below the last item description in column (6) for a given figure in both the repair parts list and special tools list work packages.

QTY (Column (7)). The QTY (quantity per figure) column indicates the quantity of the item used in the breakdown shown on the illustration/figure, which is prepared for a functional group, subfunctional group, or an assembly. A “V” appearing in this column instead of a quantity indicates that the quantity is variable and quantity may change from application to application.

**EXPLANATION OF CROSS-REFERENCE INDEX WORK PACKAGES FORMAT AND COLUMNS**

1. National Stock Number (NSN) Index Work Package.

STOCK NUMBER Column. This column lists the NSN in National item identification number (NIIN) sequence. The NIIN consists of the last nine digits of the NSN.

NSN  
 (e.g., 5385-01-574-1476)  
NIIN

When using this column to locate an item, ignore the first four digits of the NSN. However, the complete NSN should be used when ordering items by stock number.

FIG. Column. This column lists the number of the figure where the item is identified/located. The figures are in numerical order in the repair parts list and special tools list work packages.

ITEM Column. The item number identifies the item associated with the figure listed in the adjacent FIG. column. This item is also identified by the NSN listed on the same line.

2. Part Number (P/N) Index Work Package. P/Ns in this index are listed in ascending alphanumeric sequence (vertical arrangement of letter and number combinations which places the first letter or digit of each group in order A through Z, followed by the numbers 0 through 9 and each following letter or digit in like order).

PART NUMBER Column. Indicates the P/N assigned to the item.

FIG. Column. This column lists the number of the figure where the item is identified/located in the repair parts list and special tools list work packages.

ITEM Column. The item number is the number assigned to the item as it appears in the figure referenced in the adjacent figure number column.

**SPECIAL INFORMATION**

UOC. The UOC appears in the lower left corner of the Description column heading. Usable on codes are shown as “UOC: ...” in the Description column (justified left) on the first line under the applicable item/nomenclature. Uncoded items are applicable to all models. Identification of the UOCs used in the RPSTL are:

<u>Code</u>	<u>Used On</u>
FTE	20,000 Gallon, Model GTA-20KW
FTF	50,000 Gallon, Model GTA-50KW
FTP	20,000 Gallon, Model RCF-20-K-W-OB
FTQ	50,000 Gallon, Model RCF-50-K-W-OB
FTN	20,000 Gallon, Model MPC-W-20K-22276
FTO	50,000 Gallon, Model MPC-W-50K-22636

Fabrication Instructions. Bulk materials required to manufacture items are listed in the bulk material functional group of this RPSTL. Part numbers for bulk material are also referenced in the Description column of the line item entry for the item to be manufactured/fabricated. Detailed fabrication instructions for items source coded to be manufactured or fabricated are found in this manual.

Index Numbers. Items which have the word BULK in the figure column will have an index number shown in the item number column. This index number is a cross-reference between the NSN / P/N index work packages and the bulk material list in the repair parts list work package.

Illustrations List. The illustrations in this RPSTL contain unit authorized items. The tabular list in the repair parts list work package contains only those parts coded "O" in the third position of the SMR code, therefore, there may be a break in the item number sequence.

### **HOW TO LOCATE REPAIR PARTS.**

#### **1. When NSNs or P/Ns Are Not Known.**

First. Using the table of contents, determine the assembly group to which the item belongs. This is necessary since figures are prepared for assembly groups and subassembly groups, and lists are divided into the same groups.

Second. Find the figure covering the functional group or the subfunctional group to which the item belongs.

Third. Identify the item on the figure and note the number(s).

Fourth. Look in the repair parts list work packages for the figure and item numbers. The NSNs and part numbers are on the same line as the associated item numbers.

#### **2. When NSN Is Known.**

First. If you have the NSN, look in the STOCK NUMBER column of the NSN index work package. The NSN is arranged in NIIN sequence. Note the figure and item number next to the NSN.

Second. Turn to the figure and locate the item number. Verify that the item is the one you are looking for.

#### **3. When P/N Is Known.**

First. If you have the P/N and not the NSN, look in the PART NUMBER column of the P/N index work package. Identify the figure and item number.

Second. Look up the item on the figure in the applicable repair parts list work package.

### **END OF WORK PACKAGE**



UNIT MAINTENANCE

TANK, FABRIC, COLLAPSIBLE, WATER STORAGE, 20,000 AND 50,000 GALLON

TANK ASSEMBLY

REPAIR PARTS LIST

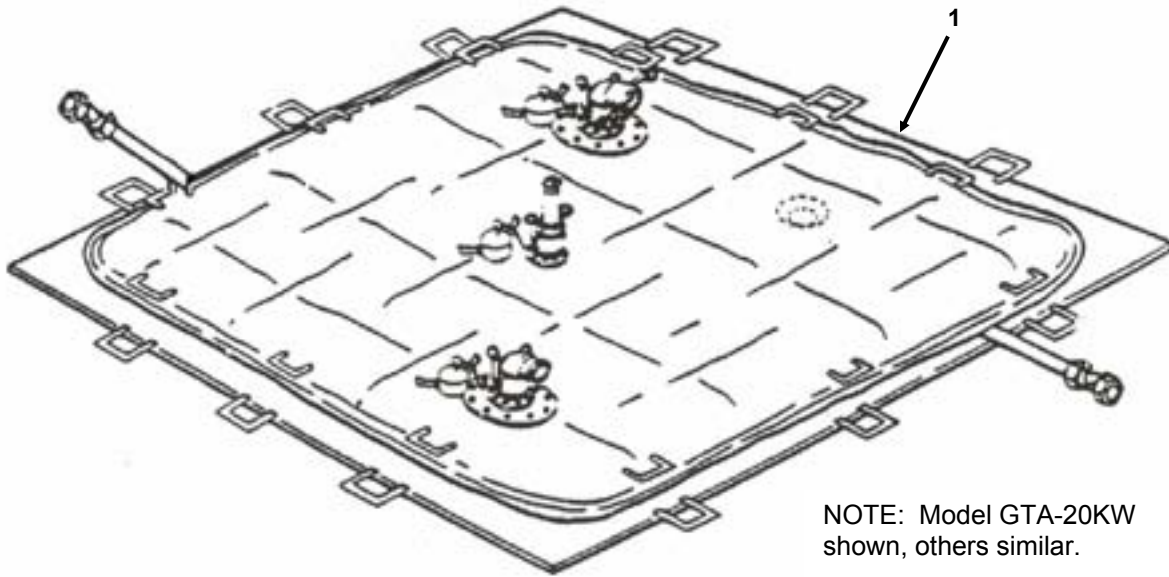

NOTE: Model GTA-20KW shown, others similar.

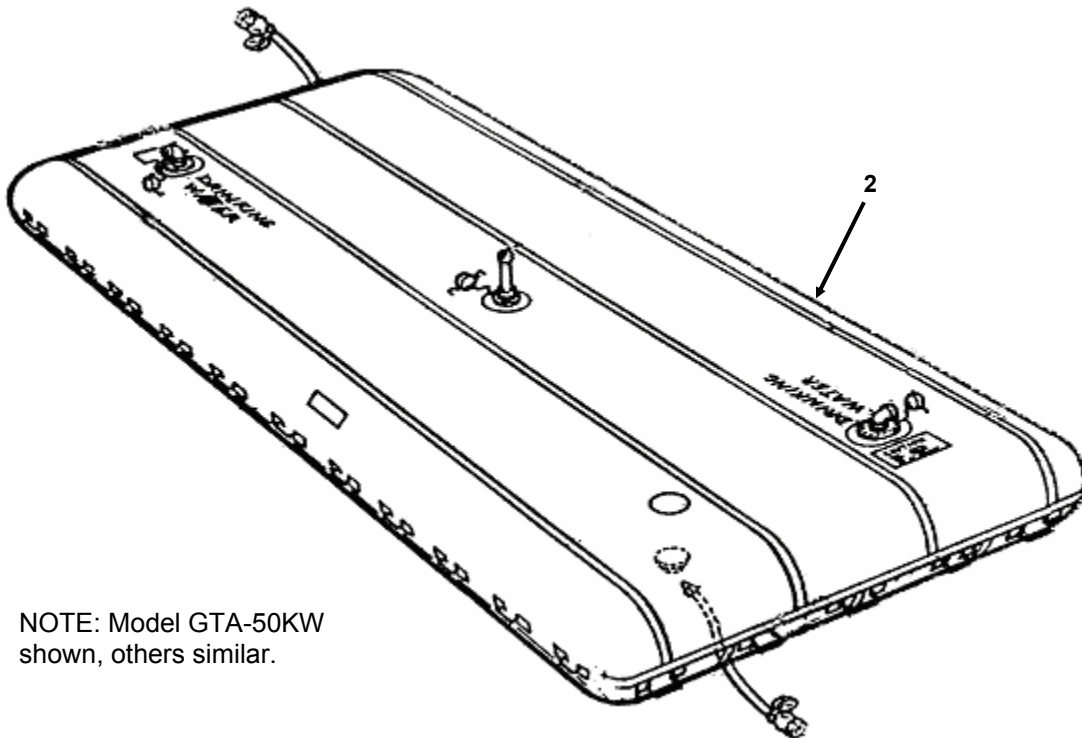

NOTE: Model GTA-50KW shown, others similar.

Figure 1. Tank Assembly.



(1) ITEM NO.	(2) SMR CODE	(3) NSN	(4) CAGEC	(5) PART NUMBER	(6) DESCRIPTION AND USABLE ON CODE (UOC)	(7) QTY
GROUP 00 TANK ASSEMBLY						
FIGURE 1. TANK ASSEMBLY						
1	PAOOO	5430-01-485-8341	0CBB4	GTA-20KW	TANK, 20,000 GALLON ..... UOC: FTE	1
1	PAOOO	5430-01-487-0633	1DFDO	RCF-20-K-W-OB	TANK, 20,000 GALLON ..... UOC: FTP	1
* 1	PAOOO	5430-01-487-0637	1EMJ6	MPC-W-20K- 22276	TANK, 20,000 GALLON ..... UOC: FTN	1
2	PAOOO	5430-01-485-8339	0CBB4	GTA-50KW	TANK, 50,000 GALLON ..... UOC: FTF	1
2	PAOOO	5430-01-486-8207	1DFDO	RCF-50-K-W-OB	TANK, 50,000 GALLON ..... UOC: FTQ	1
* 2	PAOOO	5430-01-486-8208	1EMJ6	MPC-W-50K- 22636	TANK, 50,000 GALLON ..... UOC: FTO	1

END OF FIGURE

---

UNIT MAINTENANCE

TANK, FABRIC, COLLAPSIBLE, WATER STORAGE, 20,000 AND 50,000 GALLON

TANK ENVELOPE

REPAIR PARTS LIST

---

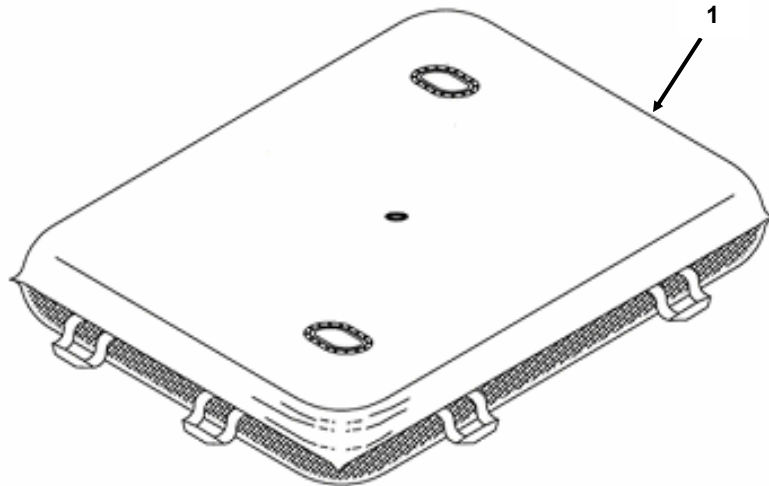

Figure 2. Tank Envelope.

(1) ITEM NO.	(2) SMR CODE	(3) NSN	(4) CAGEC	(5) PART NUMBER	(6) DESCRIPTION AND USABLE ON CODE (UOC)	(7) QTY
GROUP 01 TANK ENVELOPE						
FIGURE 2. TANK ENVELOPE						
1	XDOOO		0CBB4	GTA-20KW-RPL	TANK, FABRIC, COLLAPS ..... 20K GALLON, WATER UOC: FTE	1
1	XDOOO		1DFDO	RCF-20-K-W	TANK, FABRIC, COLLAPS ..... 20K GALLON, WATER UOC: FTP	1
* 1	XDOOO		1EMJ6	MPC-W-20K- 22276-RPL	TANK, FABRIC, COLLAPS ..... 20K GALLON, WATER UOC: FTN	1
1	XDOOO		0CBB4	GTA-50KW-RPL	TANK, FABRIC, COLLAPS ..... 50K GALLON, WATER UOC: FTF	1
1	XDOOO		1DFDO	RCF-50-K-W	TANK, FABRIC, COLLAPS ..... 50K GALLON, WATER UOC: FTQ	1
* 1	XDOOO		1EMJ6	MPC-W-50K- 22636-RPL	TANK, FABRIC, COLLAPS ..... 50K GALLON, WATER UOC: FTO	1

END OF FIGURE

UNIT MAINTENANCE

TANK, FABRIC, COLLAPSIBLE, WATER STORAGE, 20,000 AND 50,000 GALLON

VENT FITTING ASSEMBLY

REPAIR PARTS LIST

3      9  
└──┬──┘    └──┬──┘  
4      10

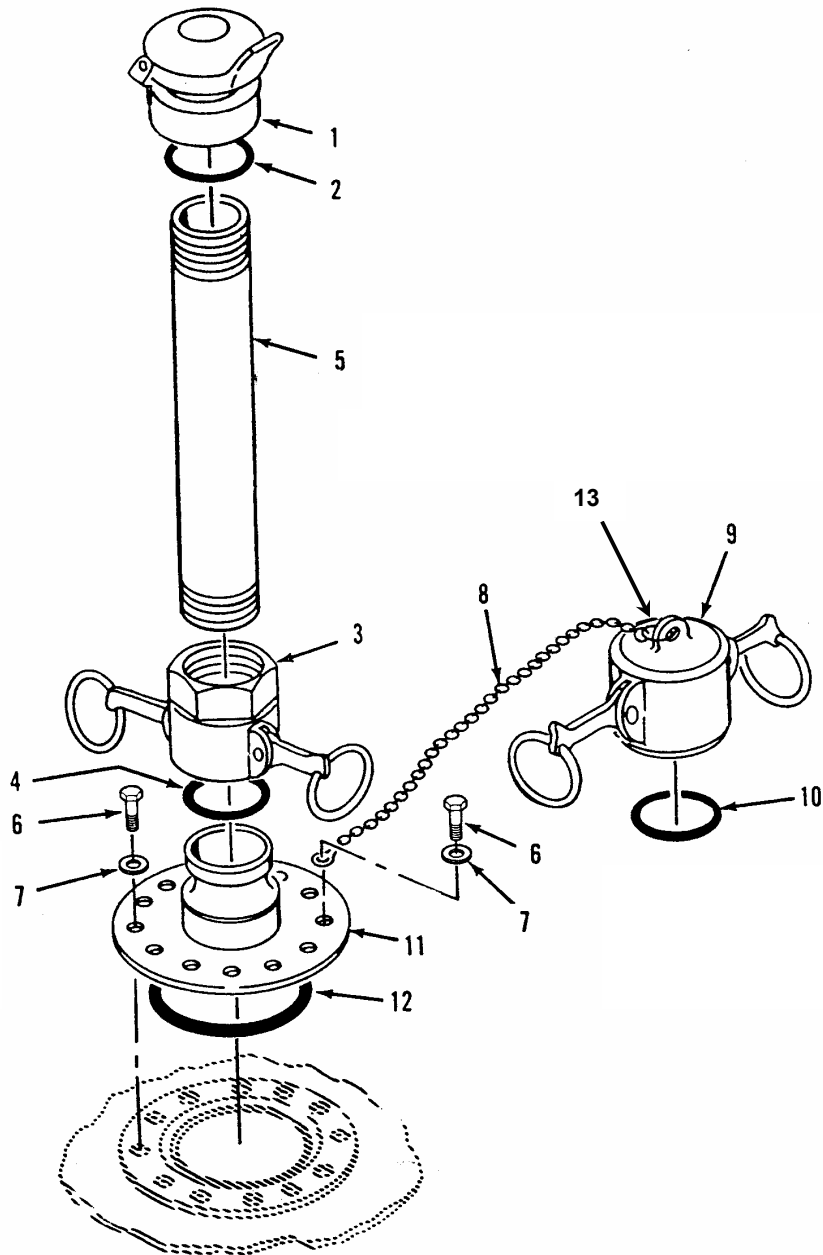

Figure 3. Vent Fitting Assembly.

(1) ITEM NO.	(2) SMR CODE	(3) NSN	(4) CAGEC	(5) PART NUMBER	(6) DESCRIPTION AND USABLE ON CODE (UOC)	(7) QTY
					GROUP 02 VENT FITTING ASSEMBLY	
					FIGURE 3. VENT FITTING ASSEMBLY	
	XDOOO		IDFDO	4965W	VENT FITTING ASSEMBLY.....1 UOC: FTP, FTQ	
	XDOOO		0CBB4	GTA-V-ASY-W	VENT FITTING ASSEMBLY.....1 UOC: FTE, FTF	
*	XDOOO		1EMJ6	MPC-WV-2-B	VENT FITTING ASSEMBLY.....1 UOC: FTN, FTO	
1	XDOZZ		0CBB4	GTA-6170	.VENT CAP, MUSHROOM.....1 TYPE WITH SCREEN UOC: FTE, FTF	
1	XDOZZ		63711	4965CF12	.VENT CAP, MUSHROOM.....1 TYPE WITH SCREEN UOC: FTP, FTQ	
* 1	XDOZZ		63711	MV-2	.VENT CAP, MUSHROOM.....1 TYPE WITH SCREEN UOC: FTN, FTO	
2	PCOZZ	5330-00-612-2414	96906	MS27030-6	.GASKET.....1	
3	PAOZZ	4730-00-649-9103	58536	AA59326V16	.COUPLING HALF, QUICK DISCONNECT...1	
4	PCOZZ	5330-00-612-2414	96906	MS27030-6	..GASKET.....1	
* 5	XDOZZ		63711	P-2-10	.PIPE, 2 INCH .....1 UOC: FTE, FTF, FTN, FTO	
5	XDOZZ		63711	4965CF8	.PIPE, 2 IN X 10 IN MALE NPT.....1 UOC: FTP, FTQ	
6	PAOZZ	5305-00-068-0509	80204	B1821BH025 C125N	.SCREW, CAP HEX HEAD .....8 1/4-20 X 1 1/4 INCH	
7	PAOZZ	5310-00-809-4058	96906	MS27183-10	.WASHER, FLAT 1/4 INCH .....8	
8	XDOZZ		63711	CARC-12	.CHAIN ASSEMBLY, SING 12 INCH, .....1 CAP ASSEMBLY UOC: FTE, FTF	
8	XDOZZ		63711	5060F7	.CHAIN, 6 INCH .....1 UOC: FTP, FTQ	
* 8	XDOZZ		63711	BRC-10-1	.CHAIN, 10 INCH .....1 UOC: FTN, FTO	
9	PAOZZ	4730-00-649-9100	58536	AA59326IX16	.CAP, QUICK DISCONNECT 2 INCH .....1	
10	PCOZZ	5330-00-612-2414	96906	MS27030-6	..GASKET, 2 INCH .....1	
11	PAOZZ	4730-01-416-1533	96906	MS27023-21	.COUPLING HALF, QUICK DISCONNECT...1	
12	PCOZZ	5331-00-291-3085	81343	AS29513-250	.O-RING GASKET, COUPLING, 4 INCH.....1	
13	XDOZZ		63711	RKC-1	.RING, KEY, 1 INCH, CAP ASSEMBLY .....1 UOC: FTE, FTF	
13	XDOZZ		63711	5060F8	.RING, KEY .....2 UOC: FTP, FTQ	
* 13	XDOZZ		63711	BRC-10-2	.RING, KEY .....2 UOC: FTN, FTO	

END OF FIGURE

UNIT MAINTENANCE

TANK, FABRIC, COLLAPSIBLE, WATER STORAGE, 20,000 AND 50,000 GALLON  
 FILLER/DISCHARGE ASSEMBLY (GTA CONTAINER MODELS)

REPAIR PARTS LIST

1  
 2 - 18

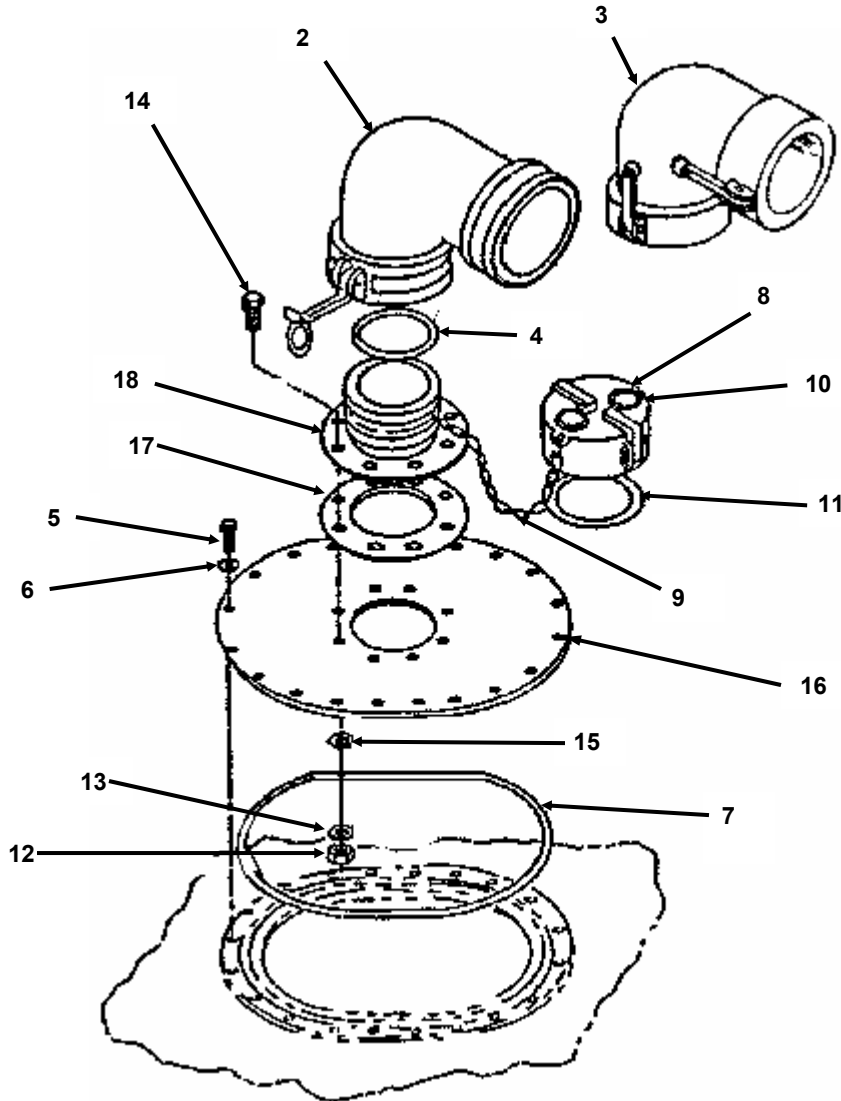

Figure 4. Filler/Discharge Assembly (GTA Container Models).

(1) ITEM NO.	(2) SMR CODE	(3) NSN	(4) CAGEC	(5) PART NUMBER	(6) DESCRIPTION AND USABLE ON CODE (UOC)	(7) QTY
					GROUP 03 ASSEMBLY, FILLER/DISCHARGE	
					FIGURE 4. FILLER/DISCHARGE ASSEMBLY (GTA CONTAINER MODELS)	
1	XDOOO		0CBB4	GTA-FD-ASY	FILLER/DISCHARGE ASSEMBLY.....	1
					UOC: FTE, FTF	
2	XDOZZ		63711	EFM-90-4	.ELBOW, FEMALE TO MALE, 4 IN,.....	1
					90 DEG	
3	XDOZZ		63711	EFF-90-4	.ELBOW, QD, FEMALE TO FEMALE,.....	1
					4 IN, 90 DEG	
4	PCOZZ	5330-00-899-4509	96906	MS27030-9	.GASKET 4 IN .....	1
5	PAOZZ	5305-00-068-0509	80204	B1821BH025 C125N	.SCREW, CAP, HEXAGON H .....	20
					1/4-20 X 1 1/4 IN	
6	PAOZZ	5310-00-809-4058	96906	MS27183-10	.WASHER, FLAT 1/4 IN .....	20
7	PCOZZ	5331-00-364-9862	81343	AS3578-383	.O-RING, 4 IN.....	1
8	PAOZZ		63711	DC-4	.CAP, QUICK DISCONNEX 4 IN.....	1
9	XDOZZ		63711	CAR-12	..CHAIN ASSEMBLY, SING 12 IN.....	1
10	XDOZZ		63711	RK-1	..RING, KEY .....	2
11	PAOZZ	5330-00-899-4509	96906	MS27030-9	..GASKET 4 IN .....	1
12	PAOZZ	5310-00-732-0558	96906	MS51967-8	.NUT, PLAIN, HEXAGON 3/8-16.....	8
13	PAOZZ	5310-00-637-9541	96906	MS35338-46	.WASHER, LOCK 3/8 IN .....	8
14	PAOZZ	5305-00-725-2317	80204	B1821BH038 C150N	.SCREW, CAP, HEXAGON H .....	8
					3/8-16 X 1 1/2 IN	
15	PCOZZ	5330-00-874-3744	83259	7500-3-8	.GASKET, 3/8 IN .....	8
16	XDOZZ		63711	GTA-063	.PLATE, CLOSURE.....	1
17	PCOZZ	5330-01-262-5120	05476	FCC-62398/ 50609735	.GASKET.....	1
18	PAOZZ	4730-00-840-5347	96906	MS27023-17	.COUPLING HALF, QUICK.....	1

END OF FIGURE

UNIT MAINTENANCE

TANK, FABRIC, COLLAPSIBLE, WATER STORAGE, 20,000 AND 50,000 GALLON

FILLER/DISCHARGE ASSEMBLY (RELIANCE AND MPC MODELS)

REPAIR PARTS LIST

RELIANCE MODELS

1

2-18

MPC MODELS

1

2-19

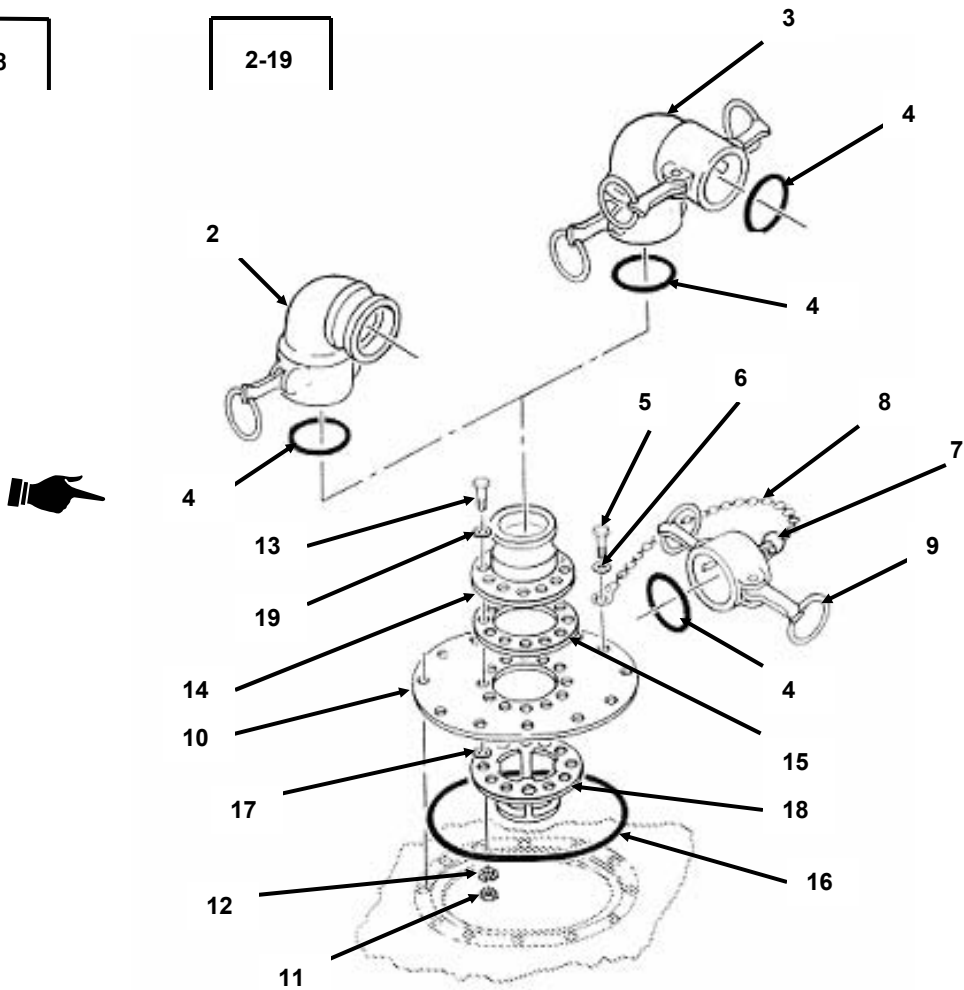

Figure 5. Filler/Discharge Assembly (Reliance and MPC Models).



(1) ITEM NO.	(2) SMR CODE	(3) NSN	(4) CAGEC	(5) PART NUMBER	(6) DESCRIPTION AND USABLE ON CODE (UOC)	(7) QTY
					GROUP 03 FILLER/DISCHARGE ASSEMBLY	
					FIGURE 5. FILLER/DISCHARGE ASSEMBLY (RELIANCE AND MPC MODELS)	
1	XDOOO		1DFDO	4963	FILLER/DISCHARGE ASSEMBLY.....1 UOC: FTP, FTQ	1
* 1	XDOOO		1EMJ6	MPC-M-W-1218-B	FILLER/DISCHARGE ASSEMBLY.....1 UOC: FTN, FTO	1
2	XDOZZ		10068	4963CF14	.ELBOW, FEMALE TO FEMALE.....1 UOC: FTP, FTQ	1
* 2	XDOZZ		63711	EFF-90-4	.ELBOW, FEMALE TO FEMALE.....1 UOC: FTN, FTO	1
3	XDOZZ		10068	4963CF7	.ELBOW, QD, FEMALE TO MALE .....1 UOC: FTP, FTQ	1
* 3	XDOZZ		63711	EFM-90-4	.ELBOW, QD, FEMALE TO MALE .....1 UOC: FTN, FTO	1
* 4	PCOZZ	5330-00-899-4509	96906	MS27030-9	.GASKET, COUPLING HALF, 4 IN .....3 UOC: FTP, FTQ, FTN, FTO	3
5	PAOZZ	5305-00-068-0509	80204	B1821BH025 C100N	.SCREW, CAP, HEXAGON.....16 UOC: FTP, FTQ	16
* 5	PAOZZ	5305-00-068-0509	80204	B1821BH025 C125N	.SCREW, CAP, HEXAGON.....20 UOC: FTN, FTO	20
* 6	PAOZZ	5310-00-809-4058	96906	MS27183-10	.WASHER, FLAT .....36 UOC: FTP, FTQ, FTN, FTO	36
* 7	PAOZZ	4730-00-640-6156	58536	AA59326IX19	.CAP, QUICK DISCONNECT .....1 USED TO COVER ITEM 14 WHEN ELBOW NOT IN PLACE UOC: FTP, FTQ, FTN, FTO	1
8	XDOZZ		63711	5060F7	..CHAIN ASSEMBLY, SING .....1 UOC: FTP, FTQ	1
* 8	XDOZZ		63711	BRC-10-1	..CHAIN ASSEMBLY, SING .....1 UOC: FTN, FTO	1
9	XDOZZ		63711	5060F8	..RING, KEY .....2 UOC: FTP, FTQ	2
* 9	XDOZZ		63711	BRC-10-2	..RING, KEY .....9 UOC: FTN, FTO	9
10	XDOZZ		63711	4963CF4	.PLATE, CLOSURE, COMPRESSION.....1 UOC: FTP, FTQ	1
* 10	XDOZZ		63711	CP-7	.PLATE, CLOSURE, COMPRESSION.....1 UOC: FTN, FTO	1
* 11	PAOZZ	5310-00-732-0558	96906	MS51967-8	.NUT, PLAIN, HEXAGON.....8 UOC: FTP, FTQ, FTN, FTO	8
* 12	PAOZZ	5310-00-637-9541	96906	MS35338-46	.WASHER, LOCK.....8 UOC: FTP, FTQ, FTN, FTO	8
* 13	PAOZZ	5305-00-725-2317	80204	B1821BH038 C150N	.SCREW, CAP, HEXAGON.....8 UOC: FTP, FTQ, FTN, FTO	8
* 14	PAOZZ	4730-00-840-5347	96906	MS27023-17	.COUPLING HALF, QUICK.....1 UOC: FTP, FTQ, FTN, FTO	1

(1) ITEM NO.	(2) SMR CODE	(3) NSN	(4) CAGEC	(5) PART NUMBER	(6) DESCRIPTION AND USABLE ON CODE (UOC)	(7) QTY
* 15	PCOZZ	5330-01-262-5120	05476	FCC-62398/ 50609735	..GASKET, COUPLING HALF ..... UOC: FTP, FTQ, FTN, FTO	1
* 16	PCOZZ	5331-00-364-9862	81343	AS3578-383	.O-RING ..... UOC: FTP, FTQ, FTN, FTO	1
* 17	PCOZZ	5330-00-874-3744	83259	7500-3-8	.GASKET, 3/8 IN ..... UOC: FTP, FTQ, FTN, FTO	8
18	XDOZZ		1BQD3	4963CF2	.SUCTION STUB, 4 IN ..... UOC: FTP, FTQ	1
* 18	XDOZZ		63711	SS-4-0-383	.SUCTION STUB, 4 IN ..... UOC: FTN, FTO	1
* 19	PCOZZ	5330-00-874-3744	83259	7500-3-8	.GASKET, 3/8 IN ..... UOC: FTN, FTO	8

END OF FIGURE



UNIT MAINTENANCE  
TANK, FABRIC, COLLAPSIBLE, WATER STORAGE, 20,000 AND 50,000 GALLON

DRAIN FITTING ASSEMBLY

REPAIR PARTS LIST

1  
2 - 10

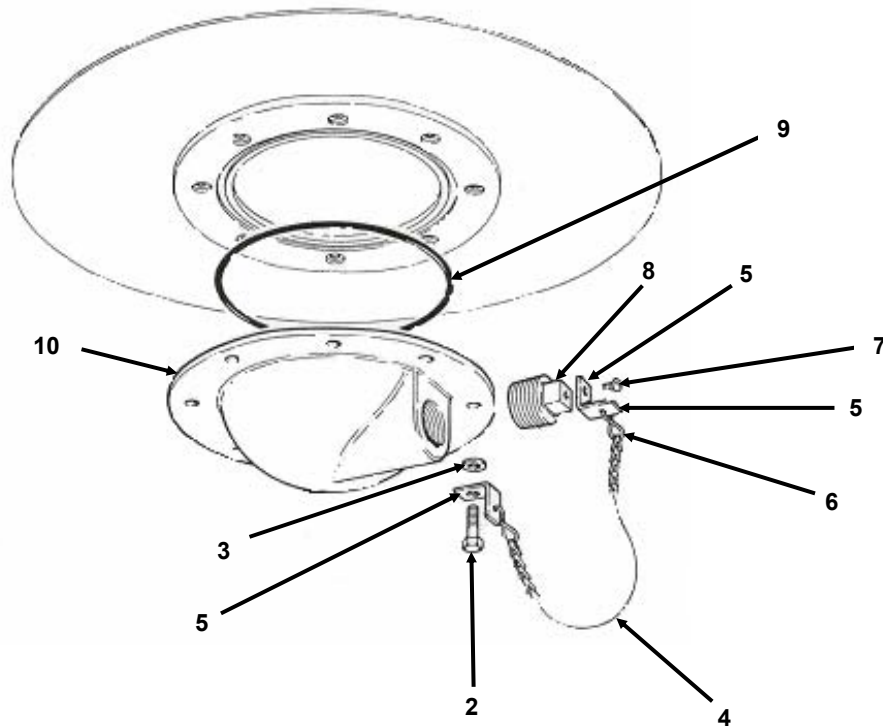

Figure 6. Drain Fitting Assembly.

(1) ITEM NO.	(2) SMR CODE	(3) NSN	(4) CAGEC	(5) PART NUMBER	(6) DESCRIPTION AND USABLE ON CODE (UOC)	(7) QTY
GROUP 04 DRAIN FITTING ASSEMBLY FIGURE 6. DRAIN FITTING ASSEMBLY						
1	XDOZZ		1DFDO	5057	DRAIN FITTING ASSEMBLY ..... UOC: FTP, FTQ	1
1	XDOZZ		0CBB4	GTA-D-ASY	DRAIN FITTING ASSEMBLY ..... UOC: FTE, FTF	1
* 1	XDOZZ		1EMJ6	MPC-WD-2-B	DRAIN FITTING ASSEMBLY ..... UOC: FTN, FTO	1
2	PAOZZ	5305-00-225-3843	80204	B1821BH025 C100N	.SCREW, CAP, HEXAGON, H ..... 1/4-20 X 1 INCH UOC: FTP, FTQ	8
* 2	PAOZZ	5305-00-068-0509	80204	B1821BH025 C125N	.SCREW, CAP, HEXAGON, H ..... 1/4-20 X 1 1/4 INCH UOC: FTE, FTF, FTN, FTO	8
* 3	PAOZZ	5310-00-809-4058	96906	MS27183-10	.WASHER, FLAT ..... UOC: FTE, FTF, FTN, FTO	8
4	XDOZZ		63711	5060F7	.CHAIN ..... UOC: FTP, FTQ	1
4	XDOZZ		63711	PC-PP-713	.CHAIN ..... UOC: FTE, FTF	1
* 4	XDOZZ		63711	BRC-10-1	.CHAIN ..... UOC: FTN, FTO	1
5	XDOZZ		63711	5057F8	.BRACKET ..... UOC: FTP, FTQ	2
5	XDOZZ		0CBB4	GTA-LB	.BRACKET ..... UOC: FTE, FTF	2
* 5	XDOZZ		1EMJ6	CBSC-12-1	.L BRACKET ..... UOC: FTN, FTO	2
6	XDOZZ		63711	5057F7	.S-HOOK ..... UOC: FTP, FTQ	2
6	XDOZZ		0CBB4	GTA-SH	.S-HOOK ..... UOC: FTE, FTF	2
* 6	XDOZZ		1EMJ6	CBSC-12-2	.S-HOOK ..... UOC: FTN, FTO	2
7	XDOZZ		63711	5057F9	.SCREW, 1/4-20 X 3/4 IN LONG ..... UOC: FTP, FTQ	1
7	XDOZZ		0CBB4	GTA1032RD	.SCREW, CAP 10/32 X 0.5 IN ..... UOC: FTE, FTF	1
* 7	PAOZZ	5305-00-068-0509	80204	B1821BH025 C125N	.SCREW, CAP, HEXAGON, H ..... 1/4-20 X 1 1/4 INCH UOC: FTN, FTO	1
8	XDOZZ		1BQD3	5057F3	.PLUG, PIPE 2 INCH ..... UOC: FTP, FTQ	1
* 8	XDOZZ		63711	PP-713	.PLUG, PIPE 2 INCH ..... UOC: FTE, FTF, FTN, FTO	1

(1) ITEM NO.	(2) SMR CODE	(3) NSN	(4) CAGEC	(5) PART NUMBER	(6) DESCRIPTION AND USABLE ON CODE (UOC)	(7) QTY
* 9	PCOZZ	5331-00-291-3085	81343	AS29513-250	.O-RING .....	1
10	XDOZZ		1BQD3	5057F2	.DRAIN, FITTING, BONNET, 2 IN..... UOC: FTP, FTQ	1
10	XDOZZ		63711	ATPD2266-DFA	.DRAIN, FITTING, BONNET, 2 IN..... UOC: FTE, FTF	1
* 10	XDOZZ		63711	DF-714	.DRAIN, FITTING, BONNET, 2 IN..... UOC: FTN, FTO	1

END OF FIGURE



---

UNIT MAINTENANCE  
TANK, FABRIC, COLLAPSIBLE, WATER STORAGE, 20,000 AND 50,000 GALLON  
DRAIN HOSE ASSEMBLY  
REPAIR PARTS LIST

---

1  
2-7

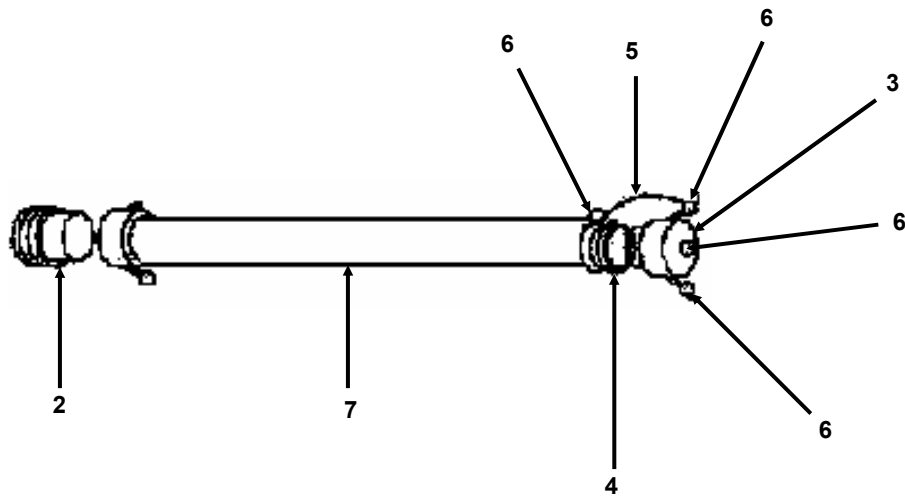

Figure 7. Drain Hose Assembly.



(1) ITEM NO.	(2) SMR CODE	(3) NSN	(4) CAGEC	(5) PART NUMBER	(6) DESCRIPTION AND USABLE ON CODE (UOC)	(7) QTY
GROUP 05 DRAIN HOSE ASSEMBLY						
FIGURE 7. DRAIN HOSE ASSEMBLY						
1	XDOOO		63711	5059C-W	HOSE ASSEMBLY, 2 IN X 8 FT,.....1 TAN, DRAIN, MNPT X MQC UOC: FTP, FTQ	1
1	XDOOO		0CBB4	GTA-2X8-H-ASY	HOSE ASSEMBLY, 2 IN X 8 FT.....1 WITH MALE NPT AND MALE QD UOC: FTE, FTF	1
* 1	XDOOO		1EMJ6	MPC-WDH-2-B	HOSE ASSEMBLY, 2 IN X 8 FT.....1 WITH MALE NPT AND MALE QD UOC: FTN, FTO	1
2	PBOZZ		63711	5059F3	.CAP, DUST, THREADED.....1 UOC: FTP, FTQ	1
* 2	PBOZZ		63711	TPC-2	.CAP, DUST, THREADED.....1 UOC: FTE, FTF, FTN, FTO	1
* 3	PAOZZ	4730-00-649-9100	58536	AA59326IX16	.CAP,DUST, QUICK DISCONNECT .....1 UOC: FTP, FTQ, FTN, FTO	1
3	PBOZZ		63711	DC-2	.CAP, DUST, QUICK DISCONNECT .....1 UOC: FTE, FTF	1
4	PCOZZ	5330-00-612-2414	96906	MS27030-6	.GASKET.....1	1
5	XDOZZ		63711	5060F7	.CHAIN, 6 INCH .....1 UOC: FTP, FTQ	1
5	XDOZZ		63711	CAR-12	.CHAIN .....1 UOC: FTE, FTF	1
* 5	XDOZZ		63711	BRC-10-1	.CHAIN .....1 UOC: FTN, FTO	1
6	XDOZZ		63711	5060F8	.RING, KEY .....4 UOC: FTP, FTQ	4
6	XDOZZ		63711	RK-1	.RING, KEY .....4 UOC: FTE, FTF	4
* 6	XDOZZ		63711	BRC-10-2	.RING, KEY .....2 UOC: FTN, FTO	2
7	XDOZZ		63711	5059C1-8-W	.HOSE, 2 IN X 8 FT .....1 UOC: FTP, FTQ	1
7	XDOZZ		63711	HA2-8-F	.HOSE, 2 IN X 8 FT .....1 UOC: FTE, FTF	1
* 7	XDOZZ		63711	NA2-8-W	.HOSE, 2 IN X 8 FT .....1 UOC: FTN, FTO	1

END OF FIGURE

UNIT MAINTENANCE  
TANK, FABRIC, COLLAPSIBLE, WATER STORAGE, 20,000 AND 50,000 GALLON

DRAIN BALL VALVE ASSEMBLY

REPAIR PARTS LIST

RELIANCE

GTA and MPC Models

1  
2-9

1  
2-8

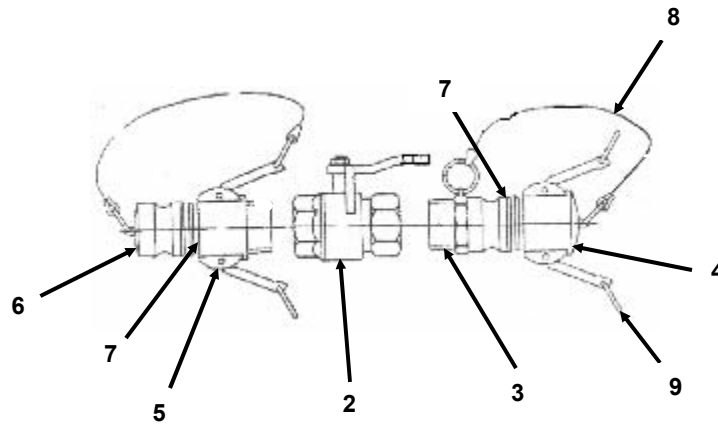

Figure 8. Drain Ball Valve Assembly.

(1) ITEM NO.	(2) SMR CODE	(3) NSN	(4) CAGEC	(5) PART NUMBER	(6) DESCRIPTION AND USABLE ON CODE (UOC)	(7) QTY
					GROUP 05 DRAIN BALL VALVE ASSEMBLY	
					FIGURE 8. DRAIN BALL VALVE ASSEMBLY	
1	XDOOO		0CBB4	GTA-2-D-VAL- ASY	BALL VALVE ASSEMBLY, 2 INCH .....1 UOC: FTE, FTF	
* 1	XDOOO		1EMJ6	MPC-WDV-2-B	BALL VALVE ASSEMBLY, 2 INCH .....1 UOC: FTN, FTO	
1	XDOOO		1DFDO	5060-2	BALL VALVE ASSEMBLY, 2 INCH .....1 UOC: FTP, FTQ	
* 2	XDOZZ		63711	ATPD2266-BVA- 26D	.BALL VALVE, 2 INCH .....1 UOC: FTE, FTF	
* 2	XDOZZ		1DFDO	5060F1	.BALL VALVE, 2 INCH .....1 UOC: FTP, FTQ	
* 2	XDOZZ		63711	WW-V- 35TY2BZ1	.BALL VALVE, 2 INCH .....1 UOC: FTN, FTO	
3	PAOZZ		63711	CH-F	.COUPLING HALF, QD, .....1 MALE X MALE NPT UOC: FTE, FTF	
* 3	PAOZZ	4730-00-938-7997	58536	AA59326III16	.COUPLING HALF, QD, .....1 MALE X MALE NPT UOC: FTP, FTQ, FTN, FTO	
4	XDOZZ		63711	DC-2	.DUST CAP, QD, 2 INCH .....1 UOC: FTE, FTF	
* 4	PAOZZ	4730-00-649-9100	58536	AA59326IX16	.DUST CAP, QUICK DISCONNECT .....1 UOC: FTP, FTQ, FTN, FTO	
5	XDOZZ		63711	CH-2B	.COUPLING HALF, QD, .....1 FEMALE X MALE NPT UOC: FTE, FTF	
* 5	PAOZZ	4730-00-088-9285	96906	MS27026-11	.COUPLING HALF, QD, .....1 FEMALE X MALE NPT UOC: FTP, FTQ, FTN, FTO	
6	XDOZZ		63711	DP-2-QD	.DUST PLUG, QD, 2 INCH .....1 UOC: FTE, FTF	
* 6	PAOZZ	4730-00-915-5127	58536	AA59326X16	.DUST PLUG, QUICK DISCONNECT .....1 UOC: FTP, FTQ, FTN, FTO	
7	XDOZZ		63711	G-QD-2	.GASKET, QD, 2 INCH .....2 UOC: FTE, FTF	
* 7	PCOZZ	5330-00-612-2414	96906	MS27030-6	.GASKET .....2 UOC: FTP, FTQ, FTN, FTO	
8	XDOZZ		63711	5060F7	.CHAIN, 6 INCH .....2 UOC: FTE, FTF	
9	XDOZZ		63711	5060F8	.RING, KEY .....7 UOC: FTP, FTQ	

END OF FIGURE

UNIT MAINTENANCE

TANK, FABRIC, COLLAPSIBLE, WATER STORAGE, 20,000 AND 50,000 GALLON  
FILLER/DISCHARGE GATE VALVE ASSEMBLY (GTA CONTAINER MODELS)

REPAIR PARTS LIST

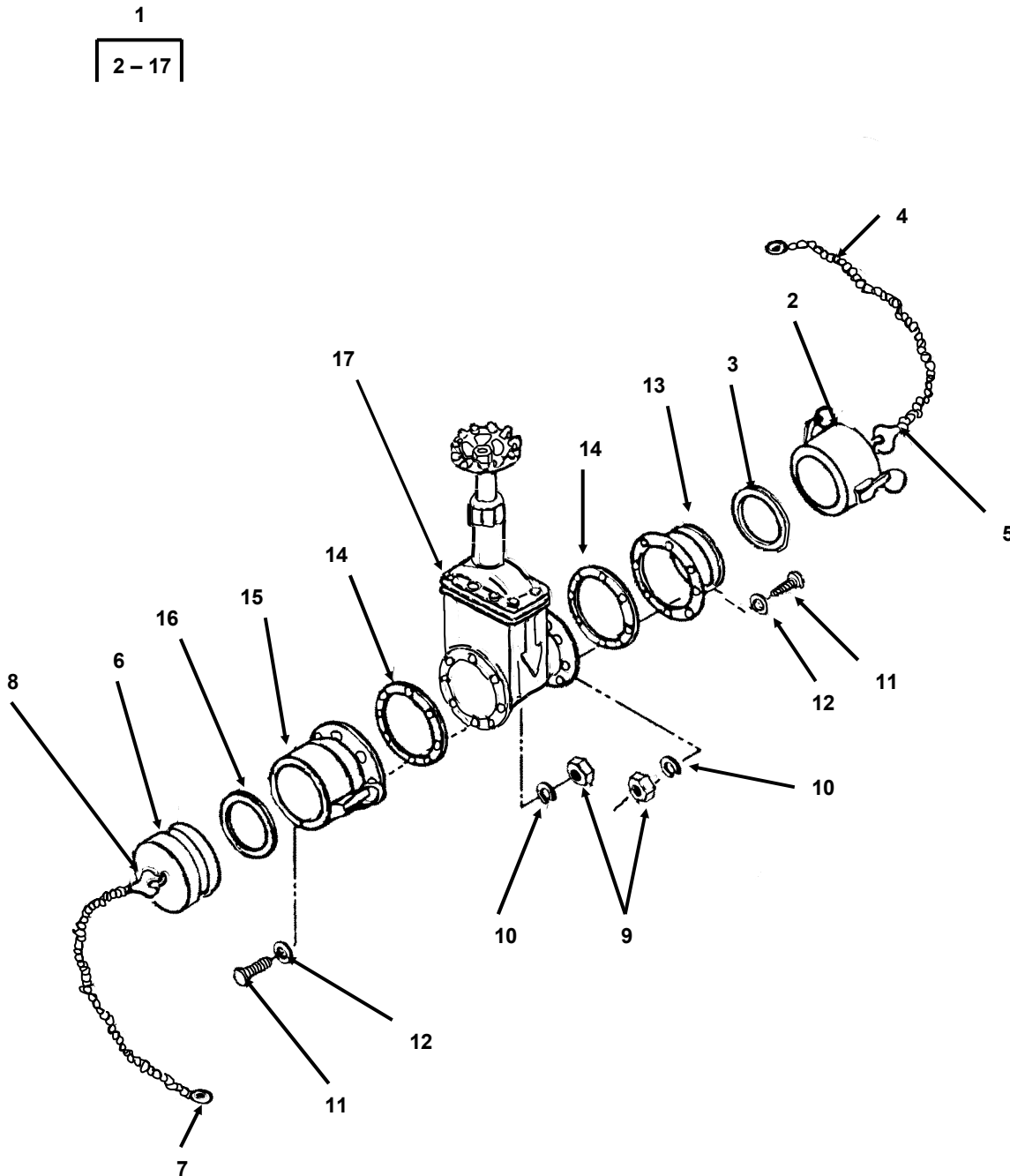

Figure 9. Filler/Discharge Gate Valve Assembly (GTA Container Models).

(1) ITEM NO.	(2) SMR CODE	(3) NSN	(4) CAGEC	(5) PART NUMBER	(6) DESCRIPTION AND USABLE ON CODE (UOC)	(7) QTY
GROUP 06 FILLER/DISCHARGE VALVE ASSEMBLY						
FIGURE 9. FILLER/DISCHARGE GATE VALVE ASSEMBLY (GTA CONTAINER MODELS)						
1	XDOOO		0CBB4	GTA-4-FD VAL-ASY	GATE VALVE ASSEMBLY,..... FILLER AND DISCHARGE UOC: FTE, FTF	1
2	PAOOZ	4730-00-640-6156	58536	AA59326IX19	.CAP, QUICK-DISCONNECT 4 IN .....	1
3	PCOZZ	5330-00-899-4509	96906	MS27030-9	..GASKET HALF, 4 IN, VALVE ASSEMBLY ..	1
4	XDOZZ		63711	CAR-12	..CHAIN ASSEMBLY, SING 12 IN,..... DUST CAP	1
5	XDOZZ		63711	RK-DC-1	..RING, KEY DUST CAP .....	2
6	PAOOZ	4730-00-640-6188	58536	AA59326X19	.PLUG, QUICK DISCONNECT VALVE .....	1
7	XDOZZ		63711	CAR-12	..CHAIN ASSEMBLY, SING 12 IN,..... DUST CAP	1
8	XDOZZ		63711	RK-DC-1	..RING, KEY DUST PLUG.....	2
9	PAOZZ	5310-00-732-0558	96906	MS51967-8	.NUT, PLAIN, HEXAGON 3/8-16,..... VALVE ASSEMBLY	16
10	PAOZZ	5310-00-637-9541	96906	MS35338-46	.WASHER, LOCK SPLIT, 3/8 IN, .....	16
11	PAOZZ	5305-00-725-2317	80204	B1821BH038 C150N	.SCREW, CAP, HEXAGON H 3/8-16..... VALVE ASSY	16
12	PAOZZ	5310-00-087-7493	96906	MS27183-13	.WASHER, FLAT 3/8 IN, VALVE ASSY .....	16
13	PAOZZ	4730-00-840-5347	96906	MS27023-17	.COUPLING HALF, QUICK .....	1
14	PCOZZ		63711	G-QD-4	.GASKET, VALVE ASSEMBLY .....	2
15	PAOZZ	4730-00-840-5348	58536	AA59326VIII14	.COUPLING HALF, QUICK .....	1
16	PCOZZ	5330-00-899-4509	96906	MS27030-9	..GASKET HALF, 4 IN VALVE..... ASSEMBLY	1
17	PAOOO	4820-01-189-2809	76364	235RF-0200AV	.VALVE, GATE VALVE ASSY .....	1

END OF FIGURE

UNIT MAINTENANCE

TANK, FABRIC, COLLAPSIBLE, WATER STORAGE, 20,000 AND 50,000 GALLON

GATE VALVE (GTA CONTAINER MODELS)

REPAIR PARTS LIST

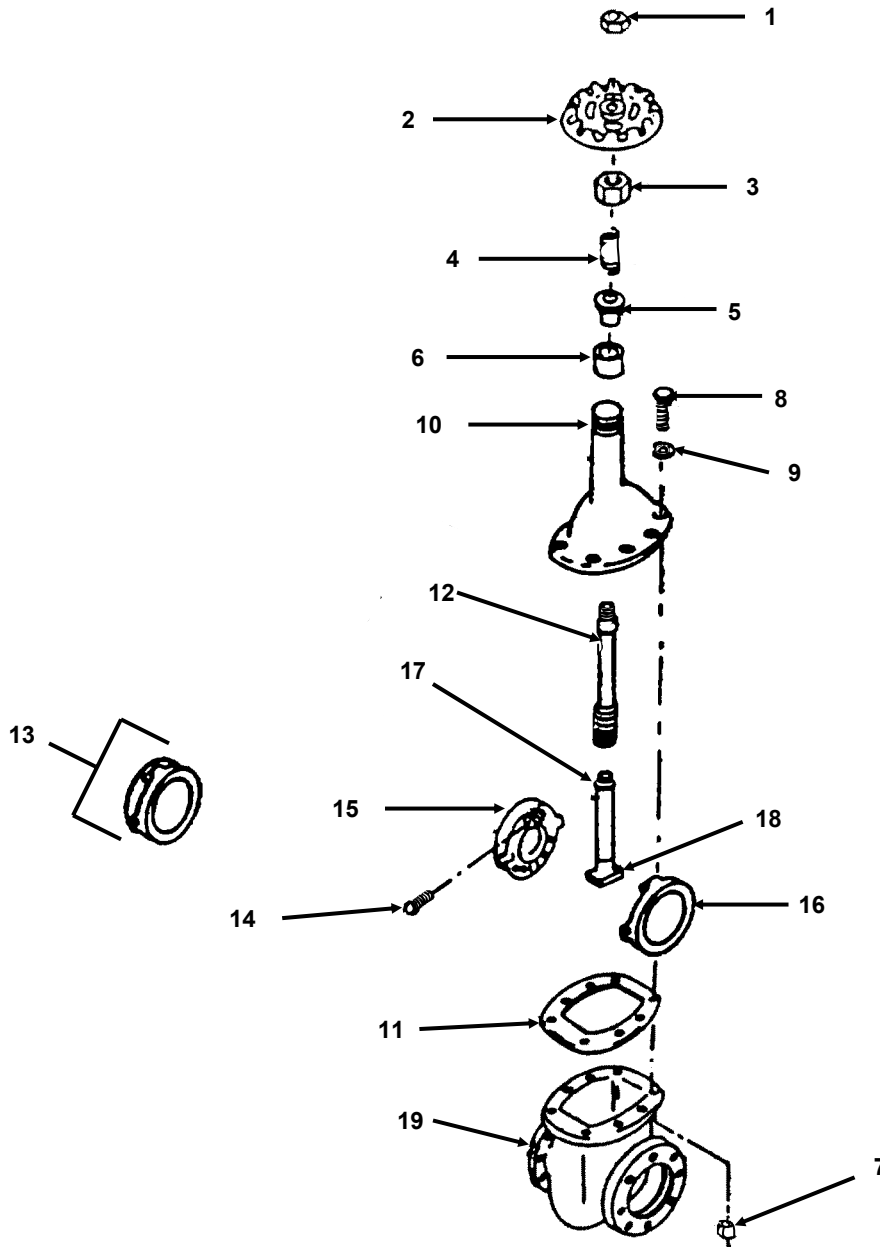

Figure 10. Gate Valve (GTA Container Models).

(1) ITEM NO.	(2) SMR CODE	(3) NSN	(4) CAGEC	(5) PART NUMBER	(6) DESCRIPTION AND USABLE ON CODE (UOC)	(7) QTY
					GROUP 06 FILLER/DISCHARGE VALVE ASSEMBLY	
					FIGURE 10. GATE VALVE ASSEMBLY (GTA CONTAINER MODELS)	
	PAOOO	4820-01-189-2809	41592	235RF-0200AV	VALVE, GATE VALVE ASSEMBLY .....1 UOC: FTE, FTF	
1	PAOZZ	5310-01-262-1359	41592	235RF-02052N	..NUT, PLAIN, HEXAGON GATE .....1 VALVE, 4 IN	
2	PAOZZ	5340-01-381-1690	41592	235RF-02043A	..HANDWHEEL, GATE VALVE, 4 IN.....1	
3	PAOZZ	5310-01-262-1337	41592	235RF-020721	..NUT, PACKING GATE VALVE, 4 IN .....1	
4	PAOZZ	5360-01-262-1338	41592	235RF-02162S	..SPRING, GLAND GATE VALVE, 4 IN .....1	
5	PAOZZ	5330-01-262-1363	41592	235RF-020621	..RETAINER, PACKING GATE .....1 VALVE, 4 IN.	
6	PAOZZ	5365-01-262-1339	41592	235RF-02082P	..RING, PACKING GATE VALVE, 4 IN .....1	
7	PAOZZ	5310-01-262-1360	41592	235RF-02202N	..NUT, PLAIN HEXAGON GATE .....1 VALVE, 4 IN.	
8	PAOZZ	5305-01-262-1365	41592	235RF-02192S	..SCREW, CAP, HEXAGON H GATE.....8 VALVE, 4 IN.	
9	PAOZZ	5310-01-265-5044	41592	235RF-02212W	..WASHER, LOCK GATE VALVE, 4 IN .....8	
10	XDOZZ		41592	235RF-0202MB	..BONNET, VALVE.....1	
11	PAOZZ	5330-01-262-1340	41592	235RF-02092G	..GASKET, VALVE BONNET .....1	
12	PAOZZ	4820-01-262-1341	41592	235RF-0203MS	..STEM, VALVE.....1	
13	PAOOZ	4820-01-262-1342	41592	235RF-0215MR	..RING, SEAT GATE VALVE, 4 IN .....1	
14	PAOZZ	5305-01-262-1343	41592	235RF-02182S	...SCREW, DISK GATE VALVE, 4 IN.....1	
15	PAOZZ	4820-01-262-1366	41592	235RF-0210MD	...DISK, VALVE GATE VALVE, 4 IN.....1	
16	PAOZZ	4820-01-262-5121	41592	235RF-0212MD	...VALVE, GATE VALVE, 4 IN .....1	
17	PAOZZ	4820-01-262-1344	41592	235RF-0217MR	..DISK, VALVE GATE VALVE, 4 IN.....1	
18	XDOZZ		76364	3042-L	..PULL, NUT .....1	
19	XDOZZ		41592	235RF-0201MB	..BODY, VALVE, 4 IN .....1	

END OF FIGURE

UNIT MAINTENANCE

TANK, FABRIC, COLLAPSIBLE, WATER STORAGE, 20,000 AND 50,000 GALLON

FILLER/DISCHARGE BALL VALVE ASSEMBLY (RELIANCE AND MPC MODELS)

REPAIR PARTS LIST

1  
2-9

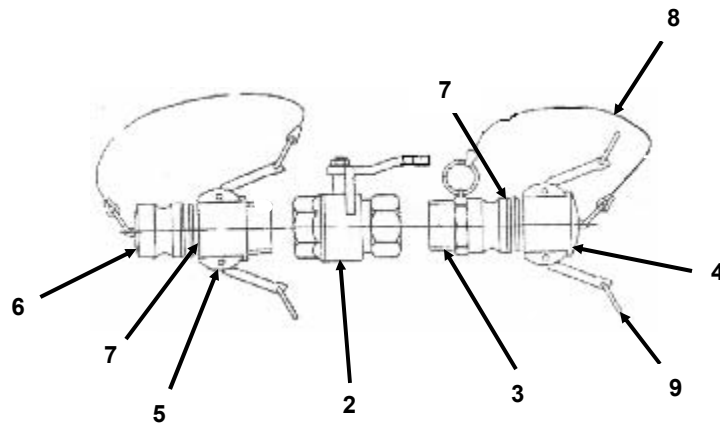

Figure 11. Filler/Discharge Ball Valve Assembly (Reliance and MPC Models).



(1) ITEM NO.	(2) SMR CODE	(3) NSN	(4) CAGEC	(5) PART NUMBER	(6) DESCRIPTION AND USABLE ON CODE (UOC)	(7) QTY
					GROUP 06 FILLER/DISCHARGE VALVE ASSEMBLY	
					FIGURE 11. FILLER/DISCHARGE BALL VALVE ASSEMBLY (RELIANCE AND MPC MODELS)	
1	XDOOO		1DFDO	5060	BALL VALVE ASSEMBLY, 4 INCH .....1 UOC: FTP, FTQ	
* 1	XDOOO		1EMJ6	MPC-WFDV-4-B	BALL VALVE ASSEMBLY, 4 INCH .....1 UOC: FTN, FTO	
* 2	XDOZZ		1DFDO	5060-4	.BALL VALVE, 4 INCH .....1 UOC: FTP, FTQ	
* 2	XDOZZ		63711	BV-WT-BZ-4	.BALL VALVE, 4 INCH .....1 UOC: FTN, FTO	
* 3	PAOZZ	4730-00-840-0797	96906	MS27022-17	.COUPLING HALF, QD, .....1 MALE X MALE NPT UOC: FTP, FTQ, FTN, FTO	
* 4	PAOZZ	4730-00-640-6156	58536	AA59326IX19	.CAP, QUICK DISCONNECT .....1 UOC: FTP, FTQ, FTN, FTO	
* 5	PAOZZ	4730-00-649-9118	58536	AA59326VII19	.COUPLING HALF, QD, .....1 FEMALE X MALE NPT UOC: FTP, FTQ, FTN, FTO	
* 6	PAOZZ	4730-00-640-6188	58536	AA59326X19	.PLUG, QUICK DISCONNECT .....1 UOC: FTP, FTQ, FTN, FTO	
* 7	PCOZZ	5330-00-075-3268	58536	A-A-59326-7	.GASKET .....2 UOC: FTP, FTQ, FTN, FTO	
* 8	XDOZZ		63711	5060F7	.CHAIN, 6 INCH .....2 UOC: FTP, FTQ	
* 8	XDOZZ		63711	BRC-10-1	.CHAIN, 10 INCH .....2 UOC: FTN, FTO	
* 9	XDOZZ		63711	5060F8	.RING, KEY .....7 UOC: FTP, FTQ	
* 9	XDOZZ		63711	BRC-10-2	.RING, KEY .....7 UOC: FTN, FTO	

END OF FIGURE

UNIT MAINTENANCE

TANK, FABRIC, COLLAPSIBLE, WATER STORAGE, 20,000 AND 50,000 GALLON

FILLER/DISCHARGE HOSE ASSEMBLY

REPAIR PARTS LIST

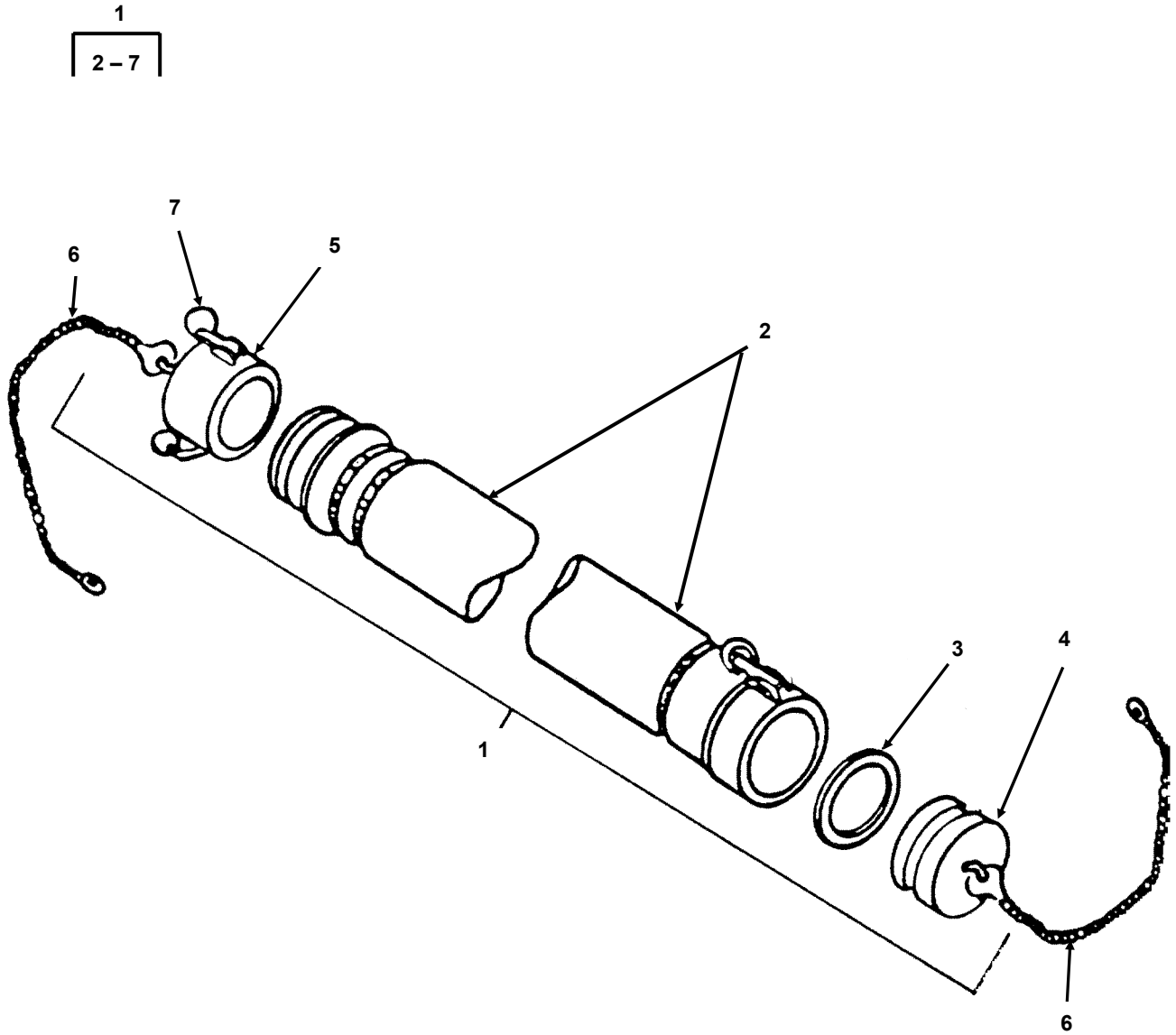

Figure 12. Filler/Discharge Hose Assembly.

(1) ITEM NO.	(2) SMR CODE	(3) NSN	(4) CAGEC	(5) PART NUMBER	(6) DESCRIPTION AND USABLE ON CODE (UOC)	(7) QTY
					GROUP 07 FILLER/DISCHARGE HOSE ASSEMBLY	
					FIGURE 12. FILLER/DISCHARGE HOSE ASSEMBLY	
1	XDOZZ		0CBB4	GTA-4X10-FD-H-ASY	HOSE ASSEMBLY, 4 IN X 10 FT.....1 WITH MALE AND FEMALE QD FITTINGS UOC: FTE, FTF	
1	XDOZZ		1DFDO	5061-W	HOSE ASSEMBLY, 4 IN X 10 FT, TAN,.....1 MALE QC X FEMALE QC UOC: FTP, FTQ	
* 1	XDOZZ		1EMJ6	MPC-WFDH-4-B	HOSE ASSEMBLY, 4 IN X 10 FT, TAN,.....1 MALE QC X FEMALE QC UOC: FTN, FTO	
2	XDOZZ		63711	ATPD2266-HA26FD	.HOSE ASSEMBLY, NONMETALLIC 4 IN X 10 FT, WITH QUICK.....1 DISCONNECT FITTINGS UOC: FTE, FTF	
2	XDOZZ		63711	5061W1	.HOSE, 4 INCH X 10 FOOT .....1 UOC: FTP, FTQ	
* 2	XDOZZ		63711	HA4-10-W	.HOSE, 4 INCH X 10 FOOT .....1 UOC: FTN, FTO	
3	PAOZZ	5330-00-899-4509	96906	MS27030-9	.GASKET, 4 IN .....2	
4	PAOZZ	4730-00-640-6188	58536	AA59326X19	.PLUG, DUST, QUICK DISCONNE.....1 4 INCH	
5	PAOZZ	4730-00-640-6156	58536	AA59326IX19	.CAP, DUST, QUICK DISCONNE .....1 4 INCH	
6	XDOZZ		63711	5060F7	.CHAIN, 6 INCH .....2 UOC: FTP, FTQ	
* 6	XDOZZ		63711	BRC-10-1	.CHAIN 10 INCH .....2 UOC: FTN, FTO	
7	XDOZZ		63711	5060F8	.RING, KEY .....7 UOC: FTP, FTQ	
* 7	XDOZZ		63711	BRC-10-2	.RING, KEY .....7 UOC: FTN, FTO	

END OF FIGURE

---

UNIT MAINTENANCE

TANK, FABRIC, COLLAPSIBLE, WATER STORAGE, 20,000 AND 50,000 GALLON

GROUND CLOTH

REPAIR PARTS LIST

---

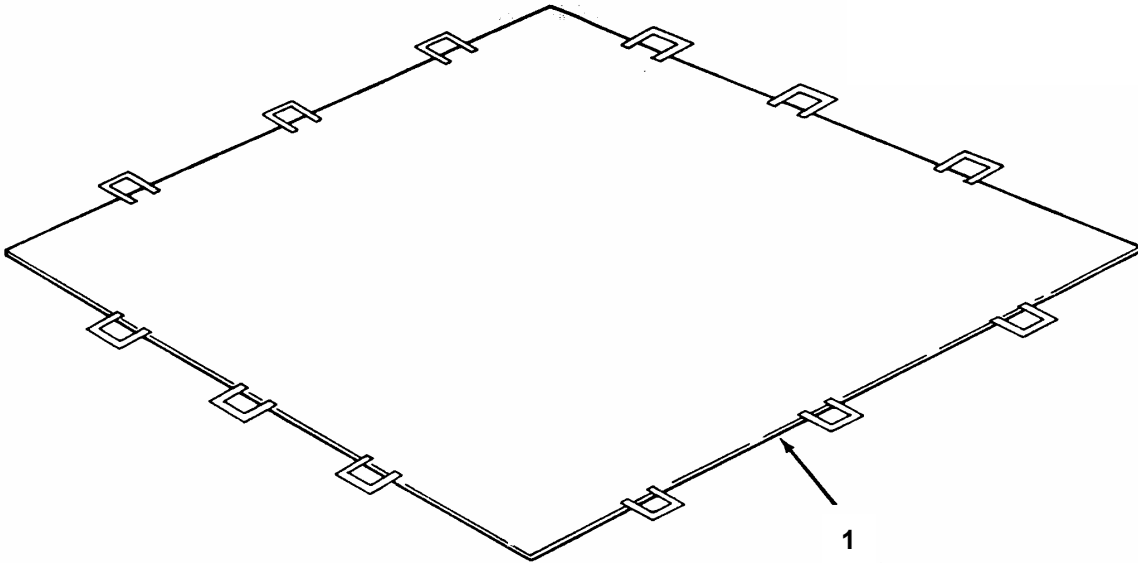

Figure 13. Ground Cloth, Typical.

(1) ITEM NO.	(2) SMR CODE	(3) NSN	(4) CAGEC	(5) PART NUMBER	(6) DESCRIPTION AND USABLE ON CODE (UOC)	(7) QTY
					GROUP 08 GROUND CLOTH	
					FIGURE 13. GROUND CLOTH	
1	XDOZZ		0CBB4	GTA-20KGC	GROUND CLOTH, 20K TANK .....1 UOC: FTE	
1	XDOZZ		1DFDO	RCF-20-K-GC-OB	GROUND CLOTH, 20K TANK .....1 UOC: FTP	
* 1	XDOZZ		1EMJ6	MPC-W-20K-GC-3131	GROUND CLOTH, 20K TANK .....1 UOC: FTN	
1	XDOZZ		0CBB4	GTA-50KGC	GROUND CLOTH, 50K TANK .....1 UOC: FTF	
1	XDOZZ		1DFDO	RCF-50-K-GC-OB	GROUND CLOTH, 50K TANK .....1 UOC: FTQ	
* 1	XDOZZ		1EMJ6	MPC-W-50K-GC-3167	GROUND CLOTH, 50K TANK .....1 UOC: FTO	

**END OF FIGURE**

UNIT MAINTENANCE

TANK, FABRIC, COLLAPSIBLE, WATER STORAGE, 20,000 AND 50,000 GALLON  
EMERGENCY REPAIR ITEMS, TYPE III REPAIR KIT (RELIANCE MODELS)

REPAIR PARTS LIST

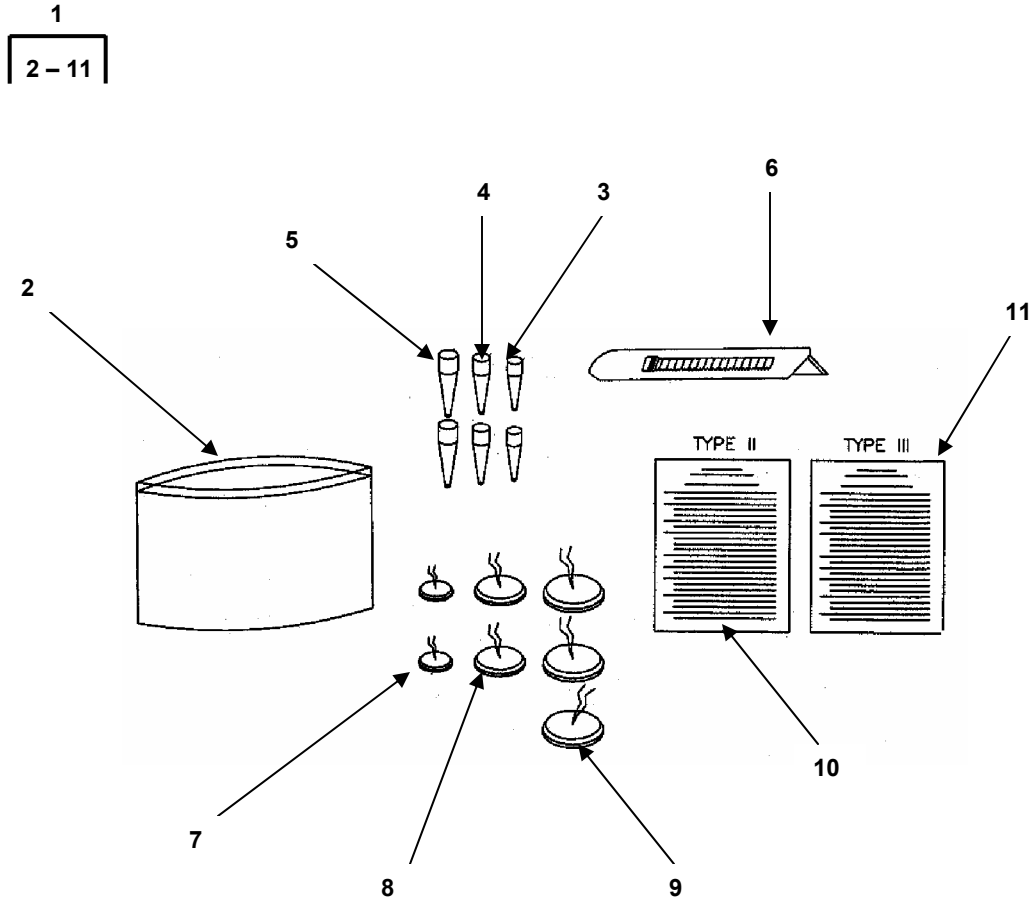

Figure 14. Emergency Repair Items, Type III Repair Kit (Reliance Models).

(1) ITEM NO.	(2) SMR CODE	(3) NSN	(4) CAGEC	(5) PART NUMBER	(6) DESCRIPTION AND USABLE ON CODE (UOC)	(7) QTY
GROUP 09 EMERGENCY REPAIR ITEMS						
FIGURE 14. EMERGENCY REPAIR ITEMS, TYPE III REPAIR KIT (RELIANCE MODELS)						
1	XDOOO		1DFDO	2263-T3-OB	REPAIR KIT, COLLAPSIBLE, ..... EMERGENCY, TYPE III UOC: FTP, FTQ	1
2	XDOZZ		84583	2263-1-OB	.CONTAINER .....	1
3	PAOZZ		84583	2263-2-OB	.PLUG, WOOD, 3 IN .....	2
4	PAOZZ		84583	2263-4-OB	.PLUG, WOOD, 4 1/2 IN.....	2
5	PAOZZ		84583	2263-6-OB	.PLUG, WOOD, 5 1/4 IN.....	2
6	XDOZZ		84583	2263-8-OB	.RAZOR/KNIFE .....	1
7	PAOZZ	5342-00-720-8864	81336	13202E2870-1	.PATCH, MECHANICAL, FL.....	2
8	PAOZZ	5342-00-720-8863	81336	13202E2870-2	.PATCH, MECHANICAL, FL.....	2
9	PAOZZ	5342-00-720-8858	81336	13202E2870-3	.PATCH, MECHANICAL, FL.....	3
10	XDOZZ		84583	2263-9-OB-II	.INSTRUCTION SHEET, TYPE II.....	1
11	XDOZZ		84583	2263-9-OB-III	.INSTRUCTION SHEET, TYPE III.....	1

END OF FIGURE

UNIT MAINTENANCE

TANK, FABRIC, COLLAPSIBLE, WATER STORAGE, 20,000 AND 50,000 GALLON  
EMERGENCY REPAIR ITEMS, TYPE III REPAIR KIT (GTA CONTAINER MODELS)

REPAIR PARTS LIST

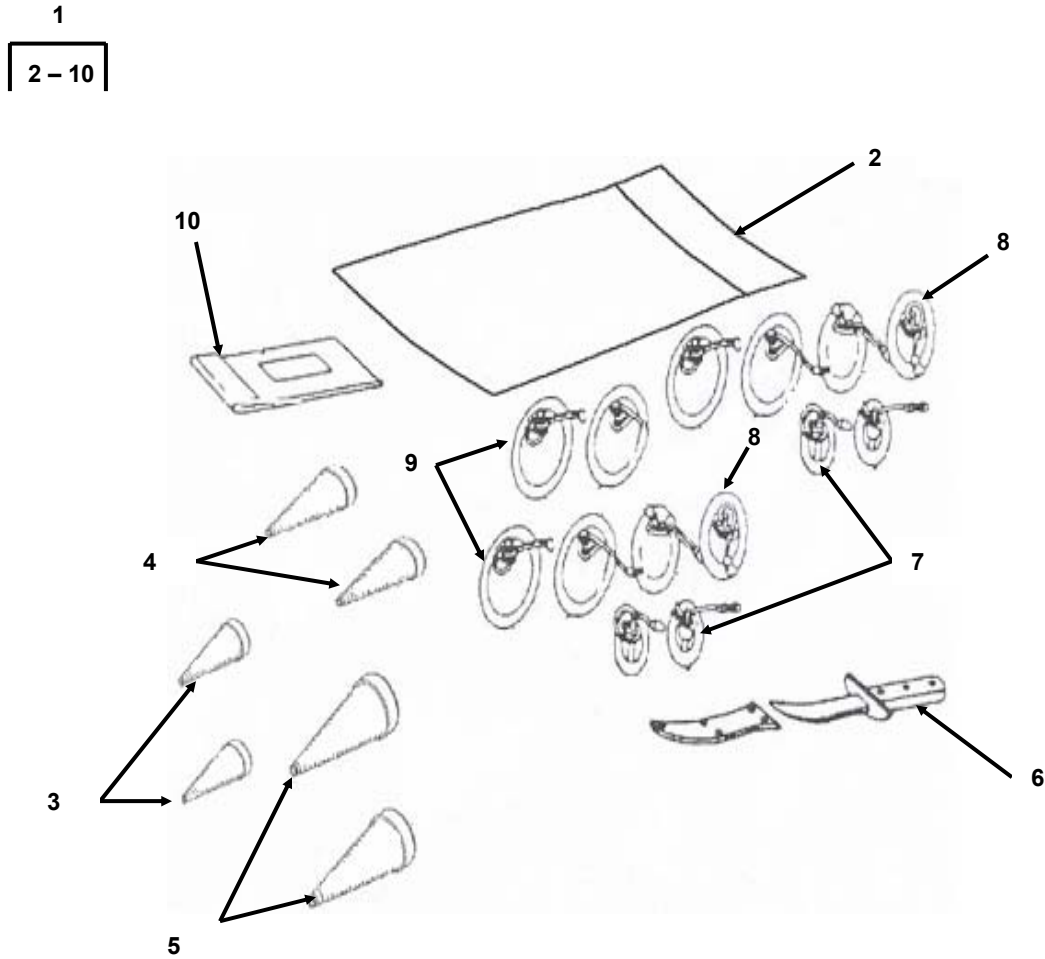

Figure 15. Emergency Repair Items, Type III Repair Kit (GTA Container Models).



(1) ITEM NO.	(2) SMR CODE	(3) NSN	(4) CAGEC	(5) PART NUMBER	(6) DESCRIPTION AND USABLE ON CODE (UOC)	(7) QTY
GROUP 09 EMERGENCY REPAIR ITEMS						
FIGURE 15. EMERGENCY REPAIR ITEMS, TYPE III REPAIR KIT (GTA CONTAINER MODELS)						
1	XDOOO		84583	52255-III	REPAIR KIT, COLLAPSIBLE ..... EMERGENCY UOC: FTE, FTF	1
2	XDOZZ		84583	52255-001	.CONTAINER .....	1
3	PAOZZ		84583	52255-002	.PLUG, WOOD, 3 IN .....	2
4	PAOZZ		84583	52255-003	.PLUG, WOOD, 4 1/2 IN.....	2
5	PAOZZ		84583	52255-004	.PLUG, WOOD, 5 1/4 IN.....	2
6	XDOZZ		84583	52255	.RAZOR/KNIFE .....	1
7	PAOZZ		84583	8864	.PATCH, MECHANICAL, FL.....	2
8	PAOZZ		84583	8863	.PATCH, MECHANICAL, FL.....	2
9	PAOZZ		84583	8858	.PATCH, MECHANICAL, FL.....	3
10	XDOZZ		84583	52255-005	.INSTRUCTION SHEET, TYPE II.....	1

END OF FIGURE

UNIT MAINTENANCE

TANK, FABRIC, COLLAPSIBLE, WATER STORAGE, 20,000 AND 50,000 GALLON

EMERGENCY REPAIR ITEMS, TYPE III REPAIR KIT (MPC MODELS)

REPAIR PARTS LIST

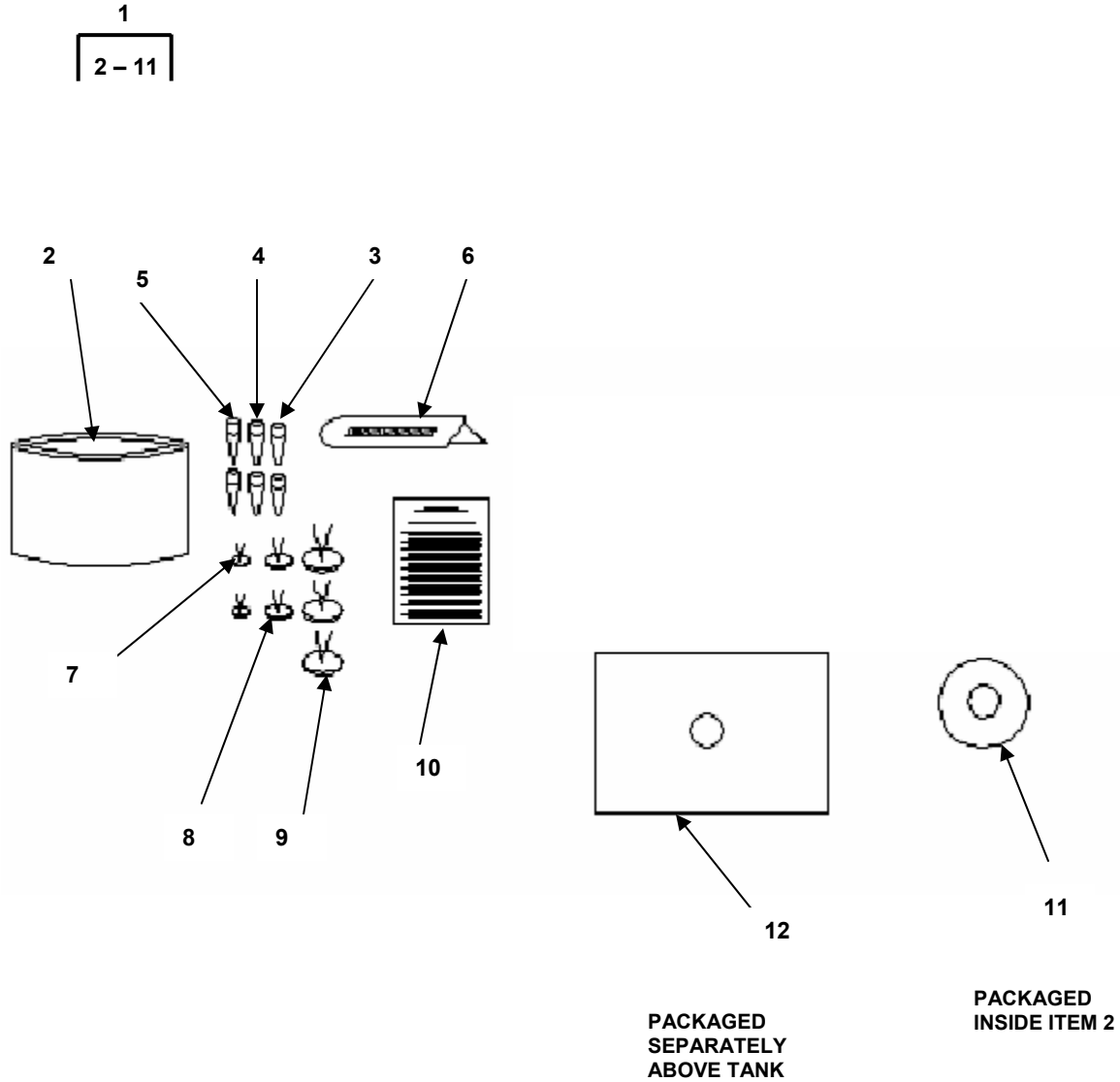

Figure 16. Emergency Repair Items, Type III Repair Kit (MPC Models).

(1) ITEM NO.	(2) SMR CODE	(3) NSN	(4) CAGEC	(5) PART NUMBER	(6) DESCRIPTION AND USABLE ON CODE (UOC)	(7) QTY
GROUP 09 EMERGENCY REPAIR ITEMS						
FIGURE 16. EMERGENCY REPAIR ITEMS, TYPE III REPAIR KIT (MPC MODELS)						
1	XDOOO		1EMJ6	MPC-RK-102-W	REPAIR KIT, COLLAPSIBLE, ..... EMERGENCY, TYPE III UOC: FTN, FT0	1
2	XDOZZ		84583	2263-3-1	.CONTAINER .....	1
3	PAOZZ		84583	2263-3-2	.PLUG, WOOD, 2.00 IN DIA.....	2
4	PAOZZ		84583	2263-3-3	.PLUG, WOOD, 1.50 IN DIA.....	2
5	PAOZZ		84583	2263-3-4	.PLUG, WOOD, 0.62 IN DIA.....	2
6	XDOZZ		84583	2263-3-5	.RAZOR/KNIFE .....	1
7	PAOZZ	5342-00-720-8864	81336	13202E2870-1	.PATCH, MECHANICAL, FL.....	2
8	PAOZZ	5342-00-720-8863	81336	13202E2870-2	.PATCH, MECHANICAL, FL.....	2
9	PAOZZ	5342-00-720-8858	81336	13202E2870-3	.PATCH, MECHANICAL, FL.....	3
10	XDOZZ		84583	2263-3-9	.INSTRUCTIONS, TYPE III REPAIR KIT .....	1
10	XDOZZ		1EMJ6	1940PWT-1Y	.TANK FABRIC REPAIR MATERIAL .....	1
11	XDOZZ		1EMJ6	TEF-.75	.TEFLON SIZING TAPE, 3/4 IN X 10 FT.....	1

END OF FIGURE

END OF WORK PACKAGE



**UNIT MAINTENANCE  
TANK, FABRIC, COLLAPSIBLE, WATER STORAGE,  
20,000 AND 50,000 GALLON  
NATIONAL STOCK NUMBER INDEX**

<b>STOCK NUMBER</b>	<b>FIG.</b>	<b>ITEM</b>	<b>STOCK NUMBER</b>	<b>FIG.</b>	<b>ITEM</b>
5305-00-068-0509	3	6	5342-00-720-8864	14	7
	4	5		*16	7
	5	5	5305-00-725-2317	4	14
	6	2		5	13
	*6	7		9	11
	11	7		4	12
5330-00-075-3268	9	12	5310-00-732-0558	5	11
5310-00-087-7493	8	5		9	9
4730-00-088-9285	6	2	5130-00-809-4058	3	7
5305-00-225-3843	3	12		4	6
5331-00-291-3085	6	9		5	6
5331-00-364-9862	4	7		6	3
	5	16		11	3
5330-00-612-2414	3	2		4730-00-840-0797	4
	3	4	4730-00-840-5347	5	14
	3	10	4730-00-840-5348	9	13
	7	4		9	15
	8	7		4	15
5310-00-637-9541	4	13	5330-00-874-3744	5	17
	5	12		*5	19
	9	10		4	4
4730-00-640-6156	5	7	5330-00-899-4509	4	11
	9	2		4	4
	11	4		5	4
	12	5		9	3
	9	6		9	16
4730-00-640-6188	9	6	12	3	
	11	6	4730-00-915-5127	8	6
	12	4	4730-00-938-7997	8	3
4730-00-649-9100	3	9	4820-01-189-2809	9	17
	7	3	5310-01-262-1337	10	-
	8	4		10	3
4730-00-649-9103	3	3	5360-01-262-1338	10	4
4730-00-649-9118	11	5	5365-01-262-1339	10	6
5342-00-720-8858	14	9	5330-01-262-1340	10	11
	*16	9	4820-01-262-1341	10	12
5342-00-720-8863	14	8			
	*16	8			

STOCK NUMBER	FIG.	ITEM	STOCK NUMBER	FIG.	ITEM
4820-01-262-1342	10	13			
5305-01-262-1343	10	14			
4820-01-262-1344	10	17			
5310-01-262-1359	10	1			
5310-01-262-1360	10	7			
5330-01-262-1363	10	5			
5305-01-262-1365	10	8			
4820-01-262-1366	10	15			
5330-01-262-5120	4	17			
	5	15			
4820-01-262-5121	10	16			
5310-01-265-5044	10	9			
5340-01-381-1690	10	2			
4730-01-416-1533	3	11			
5430-01-485-8339	1	2			
5430-01-485-8341	1	1			
5430-01-486-8207	1	2			
* 5430-01-486-8208	1	2			
5430-01-487-0633	1	1			
* 5430-01-487-0637	1	1			

END OF WORK PACKAGE

UNIT MAINTENANCE  
TANK, FABRIC, COLLAPSIBLE, WATER STORAGE,  
20,000 AND 50,000 GALLON  
PART NUMBER INDEX

PART NUMBER	FIG.	ITEM	PART NUMBER	FIG.	ITEM
A-A-59326-7	11	7		*6	7
AA59326III16	8	3	B1821BH038C150N	4	14
AA59326IX16	3	9		5	13
	7	3		9	11
	8	4	CAR-12	4	9
AA59326IX19	5	7		7	5
	9	2		9	4
	11	4		9	7
	12	5	CARC-12	3	8
AA59326V16	3	3	* CBSC-12-1	6	5
AA59326VII19	11	5	* CBSC-12-2	6	6
AA59326VIII14	9	15	CH-2B	8	5
AA59326X16	8	6	CH-F	8	3
AA59326X19	9	6	* CP-7	5	10
	11	6	DC-2	7	3
	12	4		8	4
AS29513-250	3	12	DC-4	4	8
	6	9	* DF-714	6	10
AS3578-383	4	7	DP-2-QD	8	6
	5	16	EFF-90-4	4	3
ATPD2266-BVA-26D	8	2		*5	2
ATPD2266-DFA	6	10	EFM-90-4	4	2
ATPD2266-HA26FD	12	2		*5	3
* BRC-10-1	3	8	FCC-62398/50609735	4	17
	5	8		5	15
	6	4	G-QD-2	8	7
	7	5	G-QD-4	9	14
	11	8	GTA1032RD	6	7
	12	6	GTA-063	4	16
* BRC-10-2	3	13	GTA-2-D-VAL-ASY	8	1
	5	9	GTA-20KGC	13	1
	7	6	GTA-20KW	1	1
	11	9	GTA-20KW-RPL	2	1
	12	7	GTA-2X8-H-ASY	7	1
* BV-WT-BZ-4	11	2	GTA-4-FD-VAL-ASY	9	1
B1821BH025C100N	6	2	GTA-4X10-FD-H-ASY	12	1
B1821BH025C125N	3	6			
	4	5			
	*5	5			
	6	2			

PART NUMBER	FIG.	ITEM	PART NUMBER	FIG.	ITEM
GTA-50KGC	13	1	MS27183-10	3	7
GTA-50KW	1	2		4	6
GTA-50KW-RPL	2	1		*5	6
GTA-6170	3	1		6	3
GTA-D-ASY	6	1	MS27183-13	9	12
GTA-FD-ASY	4	1	MS35338-46	4	13
GTA-LB	6	5		5	12
GTA-SH	6	6		9	10
GTA-V-ASY-W	3	-	MS51967-8	4	12
HA2-8-F	7	7		5	11
* HA4-10-W	12	2		9	9
* MPC-M-W-1218-B	5	1	* MV-2	3	1
* MPC-RK-102-W	16	1	* NA2-8-W	7	7
* MPC-W-20K-GC-3131	13	1	P-2-10	3	5
* MPC-W-50K-GC-3167	13	1	PC-PP-713	6	4
* MPC-W-20K-22276	1	1	PP-713	6	8
* MPC-W-50K-22636	1	2	RCF-20-K-GC-OB	13	1
* MPC-W-20K-22276-RPL	2	1	RCF-20-K-W	2	1
* MPC-W-50K-22636-RPL	2	1	RCF-20-K-W-OB	1	1
* MPC-WD-2-B	6	1	RCF-50-K-GC-OB	13	1
* MPC-WDH-2-B	7	1	RCF-50-K-W	2	1
* MPC-WDV-2-B	8	1	RCF-50-K-W-OB	1	2
* MPC-WFDH-4-B	12	1	RK-1	4	10
* MPC-WFDV-4-B	11	1		7	6
* MPC-WV-2-B	3	-	RK-DC-1	9	5
MS27022-17	11	3		9	8
MS27023-17	4	18	RKC-1	3	13
	5	14	* SS-4-0-383	5	18
	9	13	* TEF-.75	16	11
MS27023-21	3	11	TPC-2	7	2
MS27026-11	8	5	* WW-V-35TY2BZ1	8	2
MS27030-6	3	2	13202E2870-1	14	7
	3	4		*16	7
	3	10	13202E2870-2	14	8
	7	4		*16	8
	8	7	13202E2870-3	14	9
MS27030-9	4	4		*16	9
	4	11	*1940-PWT-1Y	16	10
	5	4	*2263-3-1	16	2
	9	3	*2263-3-2	16	3
	9	16	*2263-3-3	16	4
	12	3			



PART NUMBER	FIG.	ITEM	PART NUMBER	FIG.	ITEM
* 2263-3-4	16	5	5057F3	6	8
* 2263-3-5	16	6	5057F7	6	6
* 2263-3-9	16	10	5057F8	6	5
2263-1-OB	14	2	5057F9	6	7
2263-2-OB	14	3	5059C1-8-W	7	7
2263-4-OB	14	4	5059C-W	7	1
2263-6-OB	14	5	5059F3	7	2
2263-8-OB	14	6	5060	11	1
2263-9-OB-II	14	10	5060F1	8	2
2263-9-OB-III	14	11	5060F7	3	8
2263-T3-OB	14	1		5	8
235RF-0200AV	9	17		6	4
	10	-		7	5
235RF-0201MB	10	19		8	8
235RF-0202MB	10	10		11	8
235RF-0203MS	10	12		12	6
235RF-02043A	10	2	5060F8	3	13
235RF-02052N	10	1		5	9
235RF-020621	10	5		7	6
235RF-020721	10	3		8	9
235RF-02082P	10	6		11	9
235RF-02092G	10	11		12	7
235RF-0210MD	10	15	5060-2	8	1
235RF-0212MD	10	16	5060-4	11	2
235RF-0215MR	10	13	5061-W	12	1
235RF-02162S	10	4	5061W1	12	2
235RF-0217MR	10	17	52255	15	6
235RF-02182S	10	14	52255-III	15	1
235RF-02192S	10	8	52255-001	15	2
235RF-02202N	10	7	52255-002	15	3
235RF-02212W	10	9	52255-003	15	4
3042-L	10	18	52255-004	15	5
4963	5	1	52255-005	15	10
4963CF14	5	2	7500-3-8	4	15
4963CF2	5	18		5	17
4963CF4	5	10		*5	19
4963CF7	5	3	8858	15	9
4965CF12	3	1	8863	15	8
4965CF8	3	5	8864	15	7
4965W	3	-			
5057	6	1			
5057F2	6	10			

END OF WORK PACKAGE



**OPERATOR AND UNIT MAINTENANCE  
TANK, FABRIC, COLLAPSIBLE, WATER STORAGE,  
20,000 AND 50,000 GALLONS  
COMPONENTS OF END ITEM (COEI) AND BASIC ISSUE ITEMS (BII) LISTS**

**COMPONENTS OF END ITEM (COEI) AND BASIC ISSUE ITEMS (BII) LISTS**

**INTRODUCTION**

**Scope**

This work package lists COEI and BII for the collapsible fabric water tank to help you inventory items for safe and efficient operation of the equipment.

**General**

The COEI and BII information is divided into the following lists:

**Components of End Item (COEI).** This list is for information purposes only and is not authority to requisition replacements. These items are part of the collapsible fabric water tank. As part of the end item, these items must be with the end item whenever it is issued or transferred between property accounts. Items of COEI are removed and separately packaged for transportation or shipment only when necessary. Illustrations are furnished to help you find and identify the items.

**Basic Issue Items (BII).** These essential items are required to place the collapsible fabric water tank in operation, operate it, and to do emergency repairs. Although shipped separately packaged, BII must be with the collapsible fabric water tank during operation and when it is transferred between property accounts. Listing these items is your authority to request/requisition them for replacement based on authorization of the end item by TOE/MTOE. Illustrations are furnished to help you find and identify the items.

**Explanation of Columns in the COEI List and BII List**

Column (1) – Illus Number. Gives you the number of the item illustrated.

Column (2) – National Stock Number (NSN). Identifies the stock number of the item to be used for requisitioning purposes.

Column (3) – Description, CAGEC and Part Number. Identifies the Federal item name (in all capital letters) followed by a minimum description when needed. The stowage location of COEI and BII is also included in this column. The last line below the description is the CAGEC (commercial and Government entity code) (in parentheses) and the part number.

Column (4) – Usable on Code. When applicable, gives you a code if the item you need is not the same for different models of equipment. These codes are identified below:

<u>Code</u>	<u>Used on</u>
FTE	20,000 Gallon, Model GTA-20KW
FTF	50,000 Gallon, Model GTA-50KW
FTP	20,000 Gallon, Model RCF-20-K-W-OB
FTQ	50,000 Gallon, Model RCF-50-K-W-OB
FTN	20,000 Gallon, Model MPC-W-20K-22276
FTO	50,000 Gallon, Model MPC-W-50K-22636

Column (5) – Unit of Measure (U/M). Indicates the physical measurement or count of the item as issued per the NSN shown in column (2).

Column (6) – Qty Rqr. Indicates the quantity required.

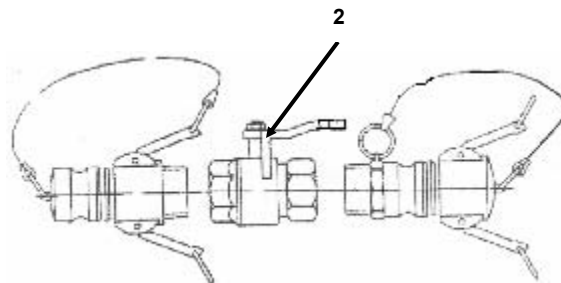
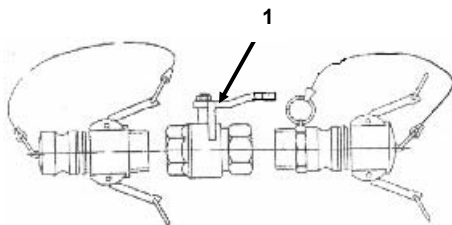

Table 1. Components of End Item List.

(1) ILLUS NUMBER	(2) NATIONAL STOCK NUMBER (NSN)	(3) DESCRIPTION, CAGEC AND PART NUMBER	(4) USABLE ON CODE	(5) UNIT OF MEASURE (U/M)	(6) QTY RQR.
1		Ball Valve Assembly, Drain, 2 Inch (1DFDO) 5060-2	FTP, FTQ	EA	2
		Ball Valve Assembly, Drain, 2 Inch (0CBB4) GTA-2-D-VAL-ASY	FTE, FTF	EA	2
		Ball Valve Assembly, Drain, 2 Inch (1EMJ6) MPC-WDV-2-B	FTN, FTO	EA	2
2		Ball Valve Assembly, Filler/Discharge, 4 Inch (1DFDO) 5060	FTP, FTQ	EA	1
		Ball Valve Assembly, Filler/Discharge, 4 Inch (1EMJ6) MPC-WFDV-4-B	FTN, FTO	EA	1

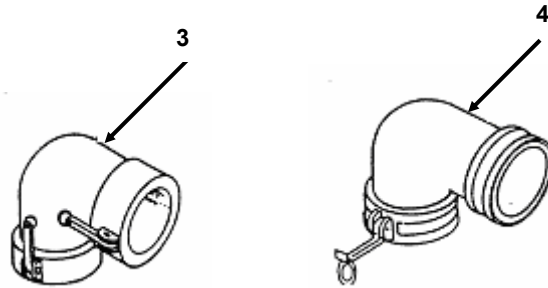

Table 1. Components of End Item List – continued.

(1) ILLUS NUMBER	(2) NATIONAL STOCK NUMBER (NSN)	(3) DESCRIPTION, CAGEC AND PART NUMBER	(4) USABLE ON CODE	(5) UNIT OF MEASURE (U/M)	(6) QTY RQR
3		Elbow, Quick Disconnect, Female/Female, 4 Inch (1DFDO) 4963CF14	FTP, FTQ	EA	1
		Elbow, Quick Disconnect Female/Female, 4 Inch (0CBB4) EFF-90-4	FTE, FTF	EA	1
		Elbow, Quick Disconnect Female/Female, 4 Inch (63711) EFF-90-4	FTN, FTO	EA	1
4		Elbow, Quick Disconnect, Female/Male, 4 Inch (1DFDO) 4963CF7	FTP, FTQ	EA	1
		Elbow, Quick Disconnect, Female/Male, 4 Inch (63711) EFM-90-4	FTN, FTO	EA	1

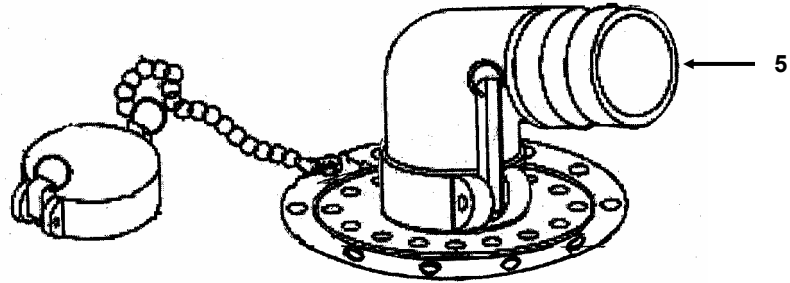

Table 1. Components of End Item List – continued.

(1) ILLUS NUMBER	(2) NATIONAL STOCK NUMBER (NSN)	(3) DESCRIPTION, CAGEC AND PART NUMBER	(4) USABLE ON CODE	(5) UNIT OF MEASURE (U/M)	(6) QTY RQR
5		Filler/Discharge Assembly, 4 Inch (1DFDO) 4963	FTP, FTQ	EA	2
		Filler/Discharge Assembly, 4 Inch (0CBB4) GTA-FD-ASY	FTE, FTF	EA	2
		Filler/Discharge Assembly, 4 Inch (1EMJ6) MPC-M-W-1218-B	FTN, FTO	EA	2

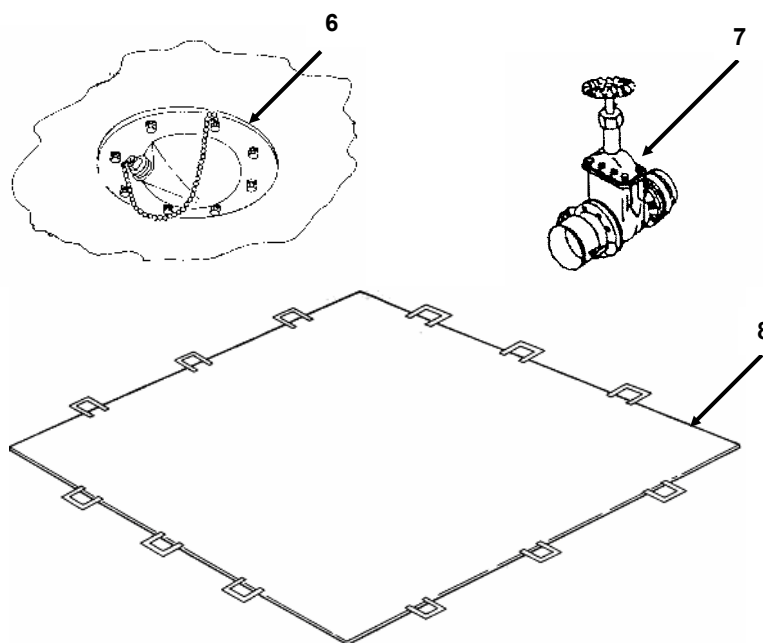

Table 1. Components of End Item List – continued.

(1) ILLUS NUMBER	(2) NATIONAL STOCK NUMBER (NSN)	(3) DESCRIPTION, CAGEC AND PART NUMBER	(4) USABLE ON CODE	(5) UNIT OF MEASURE (U/M)	(6) QTY RQR
6		Fitting Assembly, Tank Drain (1DFDO) 5057	FTP, FTQ	EA	2
		Fitting Assembly, Tank Drain (0CBB4) GTA-D-ASY	FTE, FTF	EA	2
		Fitting Assembly, Tank Drain (1EMJ6) MPC-WD-2-B	FTN, FTO	EA	2
7		Gate Valve Assembly, Filler/Discharge, 4 Inch (0CBB4) GTA-4-FD-VAL-ASY	FTE, FTF	EA	1
8		Ground Cloth, 20K Tank, Water (1DFDO) RCF-20-K-GC-OB	FTP, FTQ	EA	1
		Ground Cloth, 20K Tank, Water (0CBB4) GTA-20KGC	FTE, FTF	EA	1
		Ground Cloth, 20K Tank, Water (1EMJ6) MPC-W-20K-GC-3131	FTN	EA	1
		Ground Cloth, 50K Tank, Water (1DFDO) RCF-50-K-GC-OB	FTP, FTQ	EA	1
		Ground Cloth, 50K Tank, Water (0CBB4) GTA-50KGC	FTE, FTF	EA	1
		Ground Cloth, 50K Tank, Water (1EMJ6) MPC-W-50K-GC-3167	FTO	EA	1

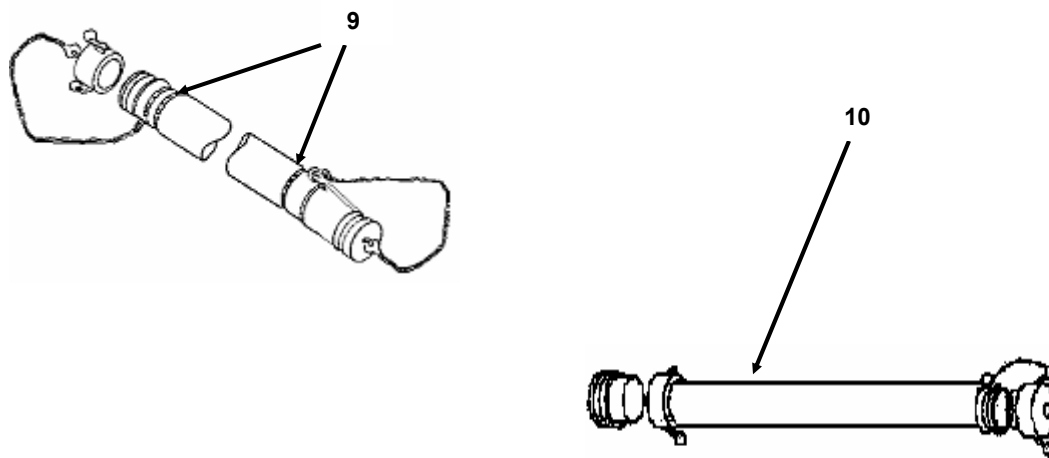

Table 1. Components of End Item List – continued.

(1) ILLUS NUMBER	(2) NATIONAL STOCK NUMBER (NSN)	(3) DESCRIPTION, CAGEC AND PART NUMBER	(4) USABLE ON CODE	(5) UNIT OF MEASURE (U/M)	(6) QTY RQR
9		Hose Assembly, Filler/Discharge, 4 Inch X 10 Foot (1DFDO) 5061-W	FTP, FTQ	EA	1
		Hose Assembly, Filler/Discharge, 4 Inch X 10 Foot (0CBB4) GTA-4X10-FD-H-ASY	FTE, FTF	EA	1
		Hose Assembly, Filler/Discharge, 4 Inch X 10 Foot (1EMJ6) MPC-WFDH-4-B	FTN, FTO	EA	1
10		Hose Assembly, Tank Drain, 2 In X 8 Ft (1DFDO) 5059C-W	FTP, FTQ	EA	2
		Hose Assembly, Tank Drain, 2 In X 8 Ft (0CBB4) GTA-2X8-H-ASY	FTE, FTF	EA	2
		Hose Assembly, Tank Drain, 2 In X 8 Ft (1EMJ6) MPC-WDH-2-B	FTN, FTO	EA	2



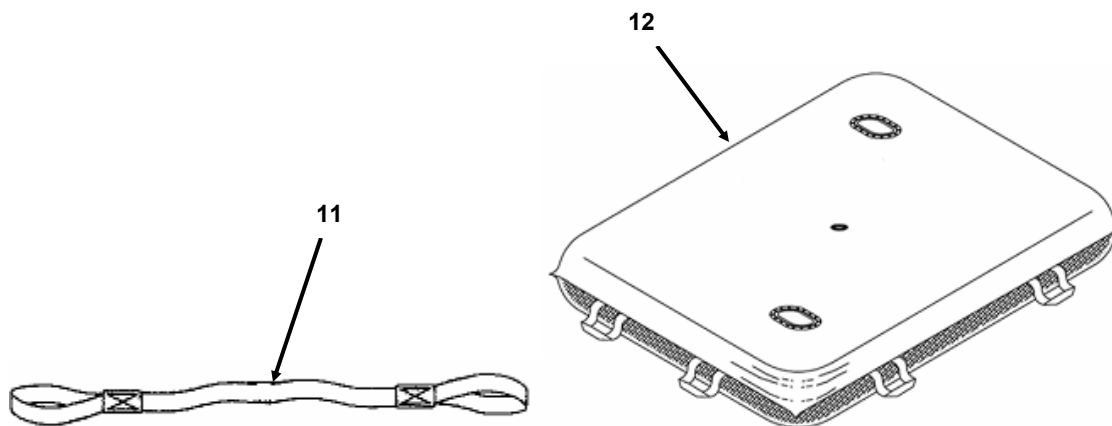

Table 1. Components of End Item List – continued.

(1) ILLUS NUMBER	(2) NATIONAL STOCK NUMBER (NSN)	(3) DESCRIPTION, CAGEC AND PART NUMBER	(4) USABLE ON CODE	(5) UNIT OF MEASURE (U/MO)	(6) QTY RQR
11		Lifting Sling, 2 Inch X 10 foot (1DFDO) EE-1-2PT-OB	FTP, FTQ	EA	2
		Lifting Sling, 2 Inch X 15 foot (1EMJ6) 011092	FTN, FTO	EA	2
12		Tank, Fabric, Collapsible, 20K, (1DFDO) RCF-20-K-W	FTE	EA	1
		Tank, Fabric, Collapsible, 20K, (0CBB4) GTA-20KW-RPL	FTP	EA	1
		Tank, Fabric, Collapsible, 20K, (1EMJ6) MPC-20KW-22276-RPL	FTN	EA	1
		Tank, Fabric, Collapsible, 50K, (1DFDO) RCF-50-K-W	FTF	EA	1
		Tank, Fabric, Collapsible, 50K, (0CBB4) GTA-50KW-RPL	FTQ	EA	1
		Tank, Fabric, Collapsible, 50K, (1EMJ6) MPC-50KW-22636-RPL	FTO	EA	1

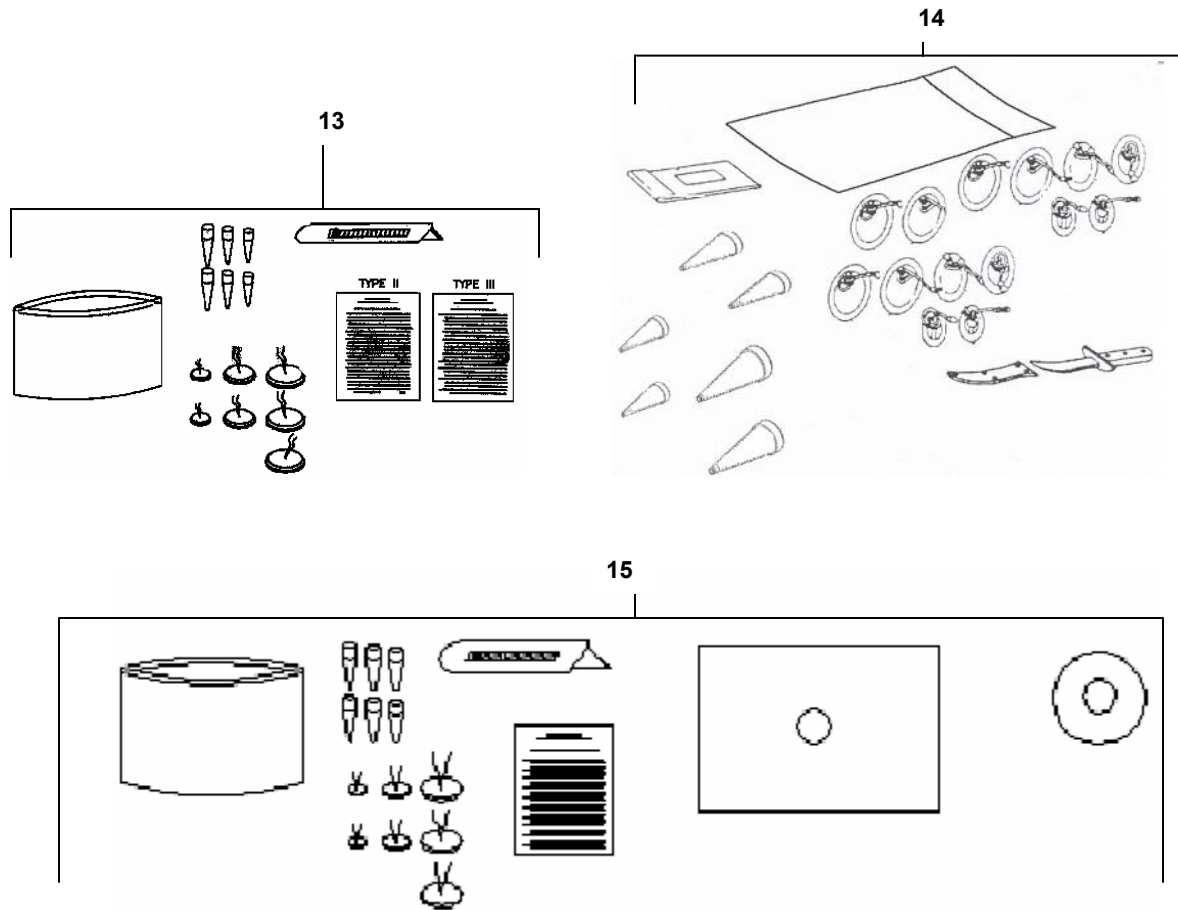

Table 1. Components of End Item List – continued.

(1) ILLUS NUMBER	(2) NATIONAL STOCK NUMBER (NSN)	(3) DESCRIPTION, CAGEC AND PART NUMBER	(4) USABLE ON CODE	(5) UNIT OF MEASURE (U/M)	(6) QTY RQR
13		Repair Kit, Collapsible, Emergency, Type III (See WP 0031 00 for Component parts) (1DFDO) 2263-T3-OB	FTP, FTQ	EA	1
14		Repair Kit, Collapsible, Emergency, Type III (See WP 0031 00 for Component parts) (0CBB4) 52255-III	FTE, FTF	EA	1
15		Repair Kit, Collapsible, Emergency, Type III (See WP 0031 00 for Component parts) (1EMJ6) MPC-RK-102-W	FTN, FTO	EA	1

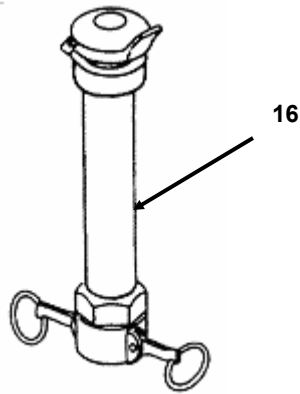

Table 1. Components of End Item List – continued.

(1) ILLUS NUMBER	(2) NATIONAL STOCK NUMBER (NSN)	(3) DESCRIPTION, CAGEC AND PART NUMBER	(4) USABLE ON CODE	(5) UNIT OF MEASURE (U/M)	(6) QTY RQR
16		Vent Fitting Assembly (1DFDO) 4965W	FTP, FTQ	EA	1
		Vent Fitting Assembly (0CBB4) GTA-V-ASY-W	FTE, FTF	EA	1
		Vent Fitting Assembly (1EMJ6) MPC-WV-20K-2-B-W	FTN, FTO	EA	1

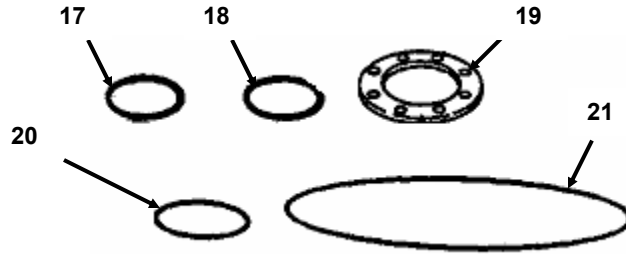

Table 1. Continued - On Board Spares.

(1) ILLUS NUMBER	(2) NATIONAL STOCK NUMBER (NSN)	(3) DESCRIPTION, CAGEC AND PART NUMBER	(4) USABLE ON CODE	(5) UNIT OF MEASURE (U/M)	(6) QTY RQR
17	5330-00-612-2414	Gasket, 2-inch (96906) MS27030-6	FTP, FTQ, FTN, FTO	EA	1
18	5330-00-899-4509	Gasket, 4-inch (96906) MS27030-9	FTP, FTQ	EA	2
18	5330-00-899-4509	Gasket, 4-inch (96906) MS27030-9	FTN, FTO	EA	1
19	5330-01-262-5120	Gasket (05476) FCC-62398/50609735	FTP, FTQ, FTN, FTO	EA	2
20	5331-00-291-3085	O-ring (81343) AS29513-250	FTP, FTQ	EA	1
20	5331-00-291-3085	O-ring (81343) AS29513-250	FTN, FTO	EA	3
21	5330-00-364-9862	O-ring (81343) AS3578-383	FTP, FTQ, FTN, FTO	EA	2

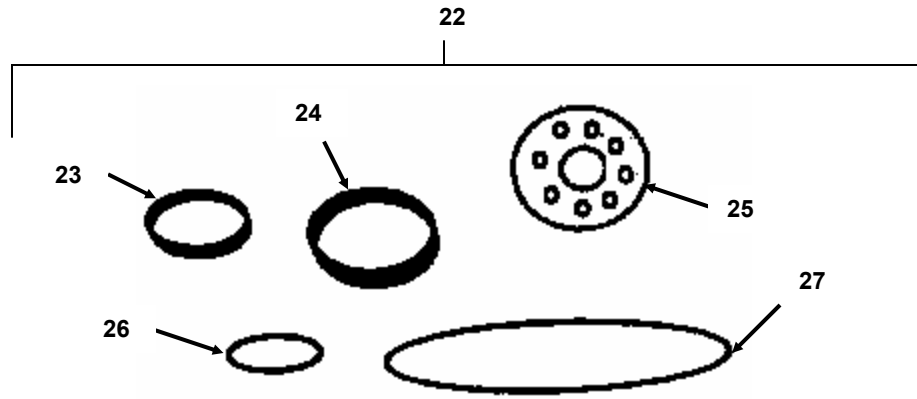

Table 1. Continued - On Board Spares.

(1) ILLUS NUMBER	(2) NATIONAL STOCK NUMBER (NSN)	(3) DESCRIPTION, CAGEC AND PART NUMBER	(4) USABLE ON CODE	(5) UNIT OF MEASURE (U/M)	(6) QTY RQR
22		Replacement O-rings and Gaskets Kit (OCBB4) GTA-ORINGS Consisting of:	FTE, FTF	EA	1
23	5330-00-612- 2414	.Gasket, 2-inch (96906) MS27030-6	FTE, FTF	EA	3
24	5330-00-899- 4509	.Gasket, 4-inch (96906) MS27030-9	FTE, FTF	EA	4
25		.Gasket, 4-inch Flange (63711) G-QD-4	FTE, FTF	EA	2
26	5331-00-291- 3085	.O-ring (81343) AS29513-250	FTE, FTF	EA	2
27	5330-00-364- 9862	.O-ring (81343) AS3578-383	FTE, FTF	EA	2

**TM 10-5430-243-12&P**

---

**TECHNICAL MANUAL**

**OPERATOR AND UNIT MAINTENANCE MANUAL  
(INCLUDING REPAIR PARTS AND SPECIAL TOOLS LIST)**

**TANK, FABRIC, COLLAPSIBLE; WATER STORAGE,  
20,000 AND 50,000 GALLONS**

**20,000 GALLONS**

<b>MODEL GTA-20KW</b>	<b>NSN 5430-01-485-8341</b>
<b>MODEL RCF-20K-W-OB</b>	<b>NSN 5430-01-487-0633</b>

**50,000 GALLONS**

<b>MODEL GTA-50KW</b>	<b>NSN 5430-01-485-8339</b>
<b>MODEL RCF-50K-W-OB</b>	<b>NSN 5430-01-486-8207</b>

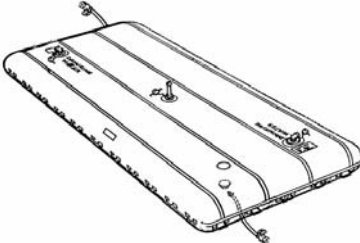

**DISTRIBUTION STATEMENT A:** Approved for public release; distribution is unlimited.

**HEADQUARTERS, DEPARTMENT OF THE ARMY**

**1 MARCH 2002**

Table 2. Basic Issue Items List.

(1) ILLUS NUMBER	(2) NATIONAL STOCK NUMBER (NSN)	(3) DESCRIPTION, CAGEC AND PART NUMBER	(4) USABLE ON CODE	(5) UNIT OF MEASURE (U/M)	(6) QTY RQR
1		TECHNICAL MANUAL, OPERATOR AND UNIT MAINTENANCE (INCL. RPSTL) TM 10-5430-243-12&P		EA	1

END OF WORK PACKAGE

---

**OPERATOR AND UNIT MAINTENANCE MANUAL  
(INCLUDING REPAIR PARTS AND SPECIAL TOOLS LIST)  
TANK, FABRIC, COLLAPSIBLE, WATER STORAGE,  
20,000 AND 50,000 GALLONS  
EXPENDABLE AND DURABLE ITEMS LIST**

---

## **EXPENDABLE AND DURABLE ITEMS LIST**

### **INTRODUCTION**

#### **Scope**

This work package lists expendable and durable items that you will need to operate and maintain the collapsible fabric water tank. This list is for information only and is not authority to requisition the listed items. These items are authorized by CTA 50-970, Expendable/Durable Items (Except Medical, Class V Repair Parts, and Heraldic Items), or CTA 8-100, Army Medical Department Expendable/Durable Items.

#### **Explanation of Columns in the Expendable/Durable Items List**

Column (1) – Item Number. This number is assigned to the entry in the list and is referenced in the narrative instructions to identify the item [e.g., “Use brake fluid (Item 5, WP 0098 00)”].

Column (2) – Level. This column identifies the lowest level of maintenance that requires the listed item (C=Operator/Crew).

Column (3) – National Stock Number (NSN). This is the NSN assigned to the item that you can use to requisition it.

Column (4) – Item Name, Description, Commercial and Government Entity Code (CAGEC), and Part Number (P/N). This column provides the other information you need to identify the item.

Column (5) – Unit of Measure (U/M). This code shows the physical measurement or count of an item, such as gallon, dozen, gross, etc.

## EXPENDABLE AND DURABLE ITEMS LIST

Table 1. Expendable and Durable Items List.

(1) ITEM NUMBER	(2) LEVEL	(3) NATIONAL STOCK NUMBER	(4) ITEM NAME, DESCRIPTION, CAGE, PART NUMBER	(5) U/M
1	O	5350-00-221-0872	Crocus Cloth (80204) ANSI B74.18	sh
2	O	7930-00-531-9716	Detergent, General Purpose (81349) MIL-D-16791	gl
3	O	9150-00-261-8291	Grease, Plug Valve (81343) SAE AMS-G-6032	ea
4	C	7920-00-205-1711	Rags, Wiping, Cotton/Synthetic (80244) 7920-00-205-1711	lb
5	O	8030-00-543-4384	Sealing Compound, Thread And Gasket, Fuel, Oil and Water (81343) AMS-S-7916	lb
6	O	6850-00-880-7613	Silicone Compound (81343) SAE-A58660	oz
7	C	8030-00-889-3535	Tape, Anti-Seize, Polyterafluorsethylene (58536) AA58092-2-2	ea
8	C	7510-00-007-4551	Tape, Pressure Sensitive Adhesive	Roll

END OF WORK PACKAGE



---

**OPERATOR AND UNIT MAINTENANCE MANUAL  
(INCLUDING REPAIR PARTS AND SPECIAL TOOLS LIST)  
TANK, FABRIC, COLLAPSIBLE, WATER STORAGE,  
20,000 AND 50,000 GALLONS  
TORQUE LIMITS**

---

## **INTRODUCTION**

This work package provides general torque limits for fasteners. Special torque values are indicated in the maintenance procedures for applicable components. The general torque values given in this work package shall be used when specific torque values are not indicated in the maintenance procedures.

### **Torque Limits**

Torque limits are listed in Table 1 for fasteners. Dry fasteners are defined as fasteners on which no lubricants are applied to the threads. Wet fasteners are defined as fasteners on which graphite or molydisulphide greases or other extreme pressure lubricants are applied to the threads. Table 2 lists the minimum breakaway torque values for locknuts.

Table 1. General Torque Requirements for Dry Fasteners\*.

Bolt/Screw Size	Torque Requirement in lb-ft (Nm)			
	SAE Grade 1 or 2	SAE Grade 5	SAE Grade 6 or 7	SAE Grade 8
1/4-20 UNC	5 (7)	8 (11)	10 (14)	12 (16)
1/4-28 UNF	7 (8)	10 (14)	12 (16)	14 (19)
5/16-18 UNC	11 (15)	17 (23)	19 (26)	24 (33)
5/16-24 UNF	13 (18)	19 (26)	23 (31)	27 (37)
3/8-16 UNC	18 (24)	31 (42)	34 (46)	44 (60)
3/8-24 UNF	20 (27)	35 (47)	42 (57)	49 (66)
7/16-14 UNC	28 (38)	49 (66)	55 (75)	70 (95)
7/16-20 UNF	30 (41)	55 (75)	67 (91)	78 (106)
1/2-13 UNC	39 (53)	75 (102)	85 (115)	105 (142)
1/2-20 UNF	41 (56)	85 (115)	102 (138)	120 (163)
9/16-12 UNC	51 (69)	110 (149)	120 (163)	155 (210)
9/16-18 UNF	55 (75)	120 (163)	145 (197)	170 (231)
5/8-11 UNC	63 (85)	150 (203)	167 (226)	210 (285)
5/8-18 UNF	95 (129)	170 (231)	205 (278)	240 (325)
3/4-10 UNC	105 (142)	270 (366)	280 (380)	375 (509)
3/4-16 UNF	115 (156)	295 (400)	357 (484)	420 (570)
7/8-9 UNC	160 (217)	395 (536)	440 (597)	605 (820)
7/8-14 UNF	175 (237)	435 (590)	555 (753)	675 (915)
1-8 UNC	235 (319)	590 (800)	660 (895)	910 (1234)
1-14 UNF	250 (339)	660 (865)	825 (1119)	999 (1342)
1-1/8-7 UN	350 (475)	800 (1085)	1000 (1356)	1280 (1736)
1-1/8-12 UNF	400 (542)	880 (1193)	1050 (1424)	1440 (1953)
1-1/4-7 UNC	500 (678)	1080 (1464)	1325 (1797)	1820 (2468)
1-1/4-12 UNF	550 (746)	1125 (1526)	1325 (1797)	1820 (2712)
1-3/8-6 UNC	660 (895)	1460 (1980)	1800 (2441)	2380 (3227)
1-3/8-12 UNF	740 (1003)	1680 (2278)	1960 (2658)	2720 (3688)
1-1/2-6 UNC	870 (1180)	1940 (2631)	2913 (3950)	3160 (4285)
1-1/2-12 UNF	980 (1329)	2200 (2983)	3000 (4068)	3560 (4827)

\*Torque given is for clean, dry threads.

**Table 2. Locknut Breakaway Torque Values.**

**NOTE**

To determine breakaway torque, thread locknut onto screw or bolt until at least two threads stick out. Locknut shall not make contact with a mating part. Stop the locknut. Torque necessary to begin turning locknut again is the breakaway torque. Do not reuse locknuts that do not meet minimum breakaway torque.

Thread Size	Minimum Breakaway Torque lb-in.	Minimum Breakaway Torque (N•m)
10-32	2.0	(0.23)
1/4-28	3.5	(0.40)
5/16-24	6.5	(0.73)
3/8-24	9.5	(1.07)
7/16-20	14.0	(1.58)
1/2-20	18.0	(2.03)
9/16-18	24.0	(2.71)
5/8-18	32.0	(3.62)
3/4-16	50.0	(5.65)
7/8-14	70.0	(7.91)
1-12	90.0	(10.17)
1-1/8-12	117.0	(13.22)

**Torque Sequence**

Torque value examples are established in the sequence shown and are itemized as follows:

Hand tighten bolts first. Next, using a torque wrench, tighten 3/8 bolts to a maximum of 15 foot pounds (20.34 N•m) for Reliance Models and a maximum of 16 foot pounds (21.70 N•m) for GTA Container Models. Second, tighten 1/4 inch bolts to 30 inch pounds (3.39 N•m). Last, tighten the 1/4 bolts to a maximum of 87 inch pounds (9.83 N•m) or to the value specified in the applicable work package.

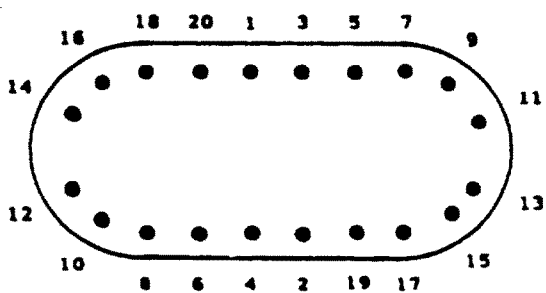

For 20 Hole Pattern

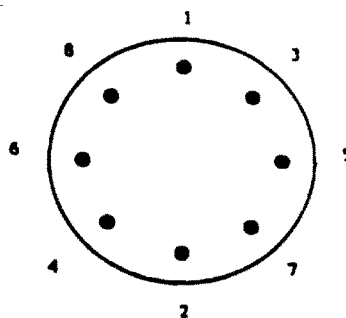

For 8 Hole Pattern

**END OF WORK PACKAGE**



**OPERATOR AND UNIT MAINTENANCE MANUAL  
(INCLUDING REPAIR PARTS AND SPECIAL TOOLS LIST)  
TANK, FABRIC, COLLAPSIBLE, WATER STORAGE,  
20,000 AND 50,000 GALLONS  
MANDATORY REPLACEMENT PARTS LIST**

**INTRODUCTION**

This work package includes a list of all mandatory replacement parts referenced in the task initial setups and procedures. These items must be replaced during maintenance, whether they have failed or not. This includes items based on usage intervals such as miles, time, rounds fired, etc.

**MANDATORY REPLACEMENT PARTS LIST**

Table 1. Mandatory Replacement Parts List

ITEM NO.	PART NUMBER/ CAGEC	NSN	NOMENCLATURE	QTY
1	MS27030-9 (96906)	5330-00-899-4509	GASKET, 4 IN.	1
2	A-A-59326-7 (58536)	5330-00-075-3268	GASKET	2
3	MS27030-6 (96906)	5330-00-612-2414	GASKET, 2 IN.	1
4	G-QD-4 (63711)		GASKET	7
5	235RF-05092G (41592)	5330-01-262-1340	GASKET, VALVE BONNET	1
6	MS35338-46 (96906)	5310-00-637-9541	LOCKWASHER	32
7	235RF-02212W (41592)	5310-01-265-5044	LOCKWASHER	8
8	EX1333B-18-95 (49234)	5330-01-262-1361	GASKET CAP	1
9	AS29513-250 (96906)	5330-00-291-3085	O-RING SEAL	1
10	AS3578-383 (81343)	5331-00-364-9862	O-RING	1
11	7500-3-8 (83259)	5330-00-874-3744	GASKET	16
12	FCC-62398/ 50609735 (05476)	5330-01-262-5120	GASKET	1

**END OF WORK PACKAGE**



## GLOSSARY

### ABBREVIATIONS

AAL.....	Additional Authorization List
Assy.....	assembly
BII.....	Basic Issue Items
bu.....	bundle
°C.....	degree Celsius
CAGEC.....	Commercial and Government Entity Code
COEI.....	Components of End Item
EIR.....	Equipment Improvement Recommendation
ESC.....	Equipment Serviceable Criteria
°F.....	degree Fahrenheit
Fed.....	Federal
gl.....	gallon
Illus.....	illustration
MTOE.....	Modified Table of Organization and Equipment
MWO.....	Modification Work Order
NSN.....	National Stock Number
PMCS.....	Preventive Maintenance Checks and Services
QA/QC.....	quality assurance/quality control
Qty.....	quantity
Rqr.....	required
SMR.....	Source, Maintenance and Recoverability
spec.....	specification
TAMMS.....	The Army Maintenance Management System
TMDE.....	Test, Measurement and Diagnostic Equipment
UOC.....	Usable On Code
U/M.....	Unit of Measure

### DEFINITION OF TERMS

#### A

APPROVED - Permitted to be used for a specific purpose by the person or group who is authorized to grant approval.

ASSEMBLY - A combination of parts that may be taken apart without destruction, which has no application or use of its own, but is needed for the completeness of a more complex item with which it is combined or to which it is attached.

#### C

COMPONENT - A part or a combination of parts, which together accomplish a function.

#### E

EXPENDABLE - An item that is not repairable and is discarded if damaged.

EXPOSURE - Being in the presence of something, or in contact with something. Skin is exposed to cleaning solvent when the solvent contacts the skin during cleaning operations.

**M**

MALFUNCTION - Occurs when a unit fails to operate normally.

MANUFACTURER - The company which makes an item or piece of equipment for sale.

MATERIEL - Equipment, apparatus and supplies of an organization, such as an army.

**R**

RECOMMENDATIONS - Suggestions for change; advice given usually to make an improvement.

REQUIRE - To demand or need.

**S**

SCOPE - The extent of an activity or concept; the amount of information covered as in a book.

SOLVENT - A liquid that can dissolve another substance.

**T**

TORQUE - Force around an axis. It produces a rotary or twisting motion, and is measured in inch-pounds (in-lb), foot-pounds (ft-lb) or Newton-meters (N•m).

**V**

VENTILATE - To provide with a source of fresh or uncontaminated air.

VISUAL - Visible; detected by the unaided eye.



INDEX

<u>Subject</u>	<u>WP Sequence No. - Page No.</u>
<b>A</b>	
Abbreviations .....	Glossary-1
Administrative Storage .....	0031 00-2
Assembly and Preparation for Use .....	0005 00-4
Auxiliary Equipment, Operation of .....	0005 00-9
<b>B</b>	
Ball Valve Assembly, Filler/Discharge (Reliance and MPC).....	0022 00-1
Ball Valve Gasket, Filler/Discharge (Reliance and MPC).....	0013 00-1
Basic Issue Items .....	0038 00-1
<b>C</b>	
Characteristics, Capabilities, and Features, Equipment .....	0002 00-1
Cleaning Tank Exterior.....	0005 00-10
Cold, Operation in Extreme.....	0006 00-1
Common Tools and Equipment .....	0017 00-1
Components, Location and Description of Major .....	0002 00-1
Components of End Item .....	0038 00-1
Controls, and Indicators, Major Components.....	0004 00-2
Corrosion Prevention and Control (CPC).....	0001 00-2
Crating Instructions .....	0031 00-2
<b>D</b>	
Decal Markings .....	0002 00-2
Decals and Data Plates.....	0007 00-1
Decals and Instruction Plates.....	0007 00-1
Decontamination Procedures, Interim Nuclear, Biological and Chemical (NBC) .....	0006 00-2
Description and Use of Controls and Indicators .....	0004 00-1
Description and Use of Major Components .....	0004 00-1
Destruction of Army Materiel to Prevent Enemy Use .....	0001 00-2
Differences Between Models .....	0002 00-1
Discharge .....	0003 00-1
Discharging the Tank .....	0005 00-8
Drain Assembly .....	0005 00-4
Drain Fitting Assembly .....	0028 00-1
Drain Hose Assembly.....	0024 00-1
Draining .....	0003 00-1
Draining, Disassembly and Exterior Tank Cleaning .....	0005 00-10
Dusty, Sandy or Snowy Conditions, Operation in .....	0006 00-1
<b>E</b>	
EIRs, Reporting Equipment Improvement Recommendations .....	0001 00-2
Elbow and Dust Cap Gasket, Filler/Discharge Assembly .....	0015 00-1
Emergency Repair Procedures.....	0006 00-3
Emergency Repair Kit Maintenance .....	0030 00-1
Emergency Repairs Using Sealing Clamps.....	0006 00-4
Emergency Repairs Using Wood Plugs.....	0006 00-3
Equipment Characteristics, Capabilities and Features .....	0002 00-1
Equipment Data .....	0002 00-3
Equipment Description and Data .....	0002 00-1
Equipment Improvement Recommendations (EIRs), Reporting.....	0001 00-2
Expendables and Durables Items List .....	0039 00-1

**Subject**

**WP Sequence No. - Page No.**

**F**

Features, Equipment Characteristics, Capabilities, and .....	0002 00-1
Filler/Discharge Assembly.....	0005 00-5
Filler/Discharge Assembly (GTA).....	0026 00-1
Filler/Discharge Assembly (Reliance and MPC).....	0027 00-1
Filler/Discharge Assembly Elbow and Dust Cap Gasket.....	0015 00-1
Filler/Discharge Ball Valve Assembly (Reliance and MPC).....	0022 00-1
Filler/Discharge Ball Valve Gasket (Reliance and MPC).....	0013 00-1
Filler/Discharge Gate Valve Assembly (GTA).....	0021 00-1
Filler/Discharge Gate Valve Hose Assembly Coupling and Dust Cap Gasket (GTA) .....	0012 00-1
Filler/Discharge Hose Assembly .....	0023 00-1
Filling .....	0003 00-1
Filling the Tank.....	0005 00-7
Folding and Packing Instructions (GTA) .....	0005 00-11
Folding and Packing Instructions (MPC).....	0005 00-17
Forms, Records and Reports, Maintenance .....	0001 00-1

**G**

Gate Valve Assembly, Filler/Discharge.....	0021 00-1
Gate Valve Hose Assembly Coupling and Dust Cap Gasket, Filler/Discharge (GTA) .....	0012 00-1
General Information .....	0001 00-1
Glossary .....	Glossary-1
Ground Cloth Maintenance .....	0029 00-1

**H**

Heat, Operation in Extreme.....	0006 00-1
High Altitudes, Operation at .....	0006 00-1
Hose Assembly, Filler/Discharge .....	0023 00-1
How to Use This Manual .....	iii

**I**

Improvement Recommendations (EIRs), Reporting Equipment.....	0001 00-2
Indicators, Controls and Major Components.....	0004 00-2
Initial Adjustments and Routine Checks .....	0005 00-8
Instruction Plates and Decals, Operating Instructions .....	0002 00-2
Instruction Plates, Decals and.....	0007 00-1
Interim Nuclear, Biological and Chemical (NBC) Decontamination Procedures .....	0006 00-2

**L**

Leakage Definitions, PMCS (Operator) .....	0010 00-2
Leakage Definitions, PMCS (Unit) .....	0019 00-1
Location and Description of Major Components .....	0002 00-1
Location of Major Components, Controls, and Indicators.....	0004 00-2
Lubrication Instructions .....	0016 00-1

**M**

Maintenance Allocation Chart.....	0033 00-1
Maintenance Forms, Records and Reports .....	0001 00-1
Maintenance Procedures, Operator.....	0011 00-1
Filler/Discharge Assembly Elbow and Dust Cap Gasket.....	0015 00-1
Filler/Discharge Ball Valve Gasket (Reliance and MPC).....	0013 00-1
Filler/Discharge Gate Valve (GTA), Hose Assembly Coupling and Dust Cap Gasket .....	0012 00-1
Vent Fitting Assembly Coupling and Dust Cap Gasket .....	0014 00-1
Maintenance Procedures, Unit.....	0020 00-1
Drain Fitting Assembly .....	0028 00-1
Drain Hose Assembly.....	0024 00-1

**Subject**

**WP Sequence No. - Page No.**

**M (continued)**

Emergency Repair Kit Maintenance .....	0030 00-1
Filler/Discharge Assembly (GTA).....	0026 00-1
Filler/Discharge Assembly (Reliance and MPC).....	0027 00-1
Filler/Discharge Ball Valve Assembly (Reliance and MPC).....	0022 00-1
Filler/Discharge Gate Valve Assembly.....	0021 00-1
Filler/Discharge Hose Assembly .....	0023 00-1
Ground Cloth Maintenance .....	0029 00-1
Preparation for Storage or Shipment .....	0031 00-1
Vent Fitting Assembly .....	0025 00-1
Major Components, Controls and Indicators.....	0004 00-2
Mandatory Replacement Parts List.....	0041 00-1
Movement, Preparation for.....	0005 00-10

**N**

NBC Emergency Procedures .....	0006 00-2
National Stock Number Index .....	0036 00-1
Nuclear, Biological and Chemical (NBC) Decontamination Procedures .....	0006 00-2

**O**

Operating Instructions on Instruction Plates and Decals .....	0002 00-2
Operating Procedures .....	0005 00-6
Operation at High Altitudes .....	0006-00-1
Operation in Dusty, Sandy or Snowy Conditions .....	0006 00-1
Operation in Extreme Cold.....	0006 00-1
Operation in Extreme Heat.....	0006 00-1
Operation in Salt Water Areas .....	0006 00-1
Operation in Windy Conditions .....	0006 00-2
Operation Under Unusual Conditions .....	0006 00-1
Operation Under Usual Conditions .....	0005 00-1
Operation of Auxiliary Equipment .....	0005 00-9
Operator Maintenance Procedures.....	0011 00-1
Filler/Discharge Assembly Elbow and Dust Cap Gasket .....	0015 00-1
Filler/Discharge Ball Valve Gasket (Reliance and MPC).....	0013 00-1
Filler/Discharge Gate Valve (GTA), Hose Assembly Coupling and Dust Cap Gasket .....	0012 00-1
Vent Fitting Assembly Coupling and Dust Cap Gasket .....	0014 00-1
Operator PMCS Procedures .....	0010 00-1
Operator Troubleshooting Procedures.....	0008 00-1

**P**

Packing and Folding Instructions (GTA) .....	0005 00-11
Packing and Folding Instructions (MPC).....	0005 00-17
Packing In a Reusable Container .....	0005 00-18
Packing the Tank in Standardized Container.....	0005 00-18
Part Number Index .....	0037 00-1
PMCS Leakage Definitions, Operator.....	0010 00-2
PMCS Leakage Definitions, Unit.....	0019 00-1
PMCS Procedures, Operator .....	0010 00-1
PMCS Procedures, Unit.....	0019 00-1
Preliminary Servicing and Adjustment of Equipment.....	0018 00-3
Preparation for Movement.....	0005 00-10
Preparation for Storage or Shipment .....	0031 00-1
Preparation for Use, Assembly and .....	0005 00-4
Personnel Safety .....	0020 00-1
Proper Equipment .....	0020 00-1

**Subject**

**WP Sequence No. - Page No.**

**Q**

Quality Assurance/Quality Control (QA/QC).....0001 00-2

**R**

Records and Reports, Maintenance Forms, .....0001 00-1  
 References .....0032 00-1  
 Repair Parts and Special Tools List Introduction .....0034 00-1  
 Repair Parts List.....0035 00-1  
 Repair Procedures, Emergency .....0006 00-3  
 Repairs Using Sealing Clamps, Emergency .....0006 00-4  
 Repairs Using Wood Plugs, Emergency .....0006 00-3  
 Reporting Equipment Improvement Recommendations (EIRs).....0001 00-2  
 Routine Checks, Initial Adjustments and .....0005 00-8

**S**

Salt Water Areas, Operation in .....0006 00-1  
 Scope .....0001 00-1  
 Service Upon Receipt of Materiel .....0018 00-1  
 Servicing and Adjustment of Equipment, Preliminary .....0018 00-3  
 Shipment, Preparation for Storage or .....0031 00-1  
 Siting Requirements .....0005 00-1  
 Special Tools, TMDE and Support Equipment .....0017 00-1  
 Storage or Shipment, Preparation for .....0031 00-1  
 Support Equipment, Special Tools, TMDE, and .....0017 00-1

**T**

Theory of Operation .....0003 00-1  
 Tools, TMDE, and Support Equipment, Special .....0017 00-1  
 Torque Limits .....0040 00-1  
 Troubleshooting Procedures, Operator.....0008 00-1  
 Troubleshooting Procedures, Unit .....0009 00-1

**U**

Unit Maintenance Procedures.....0020 00-1  
 Drain Fitting Assembly .....0028 00-1  
 Drain Hose Assembly.....0024 00-1  
 Emergency Repair Kit Maintenance .....0030 00-1  
 Filler/Discharge Assembly (GTA).....0026 00-1  
 Filler/Discharge Assembly (Reliance and MPC).....0027 00-1  
 Filler/Discharge Ball Valve Assembly (Reliance and MPC).....0022 00-1  
 Filler/Discharge Gate Valve Assembly.....0021 00-1  
 Filler/Discharge Hose Assembly .....0023 00-1  
 Ground Cloth Maintenance .....0029 00-1  
 Preparation for Storage or Shipment .....0031 00-1  
 Vent Fitting Assembly .....0025 00-1  
 Unit PMCS Procedures .....0019 00-1  
 Unit Service Upon Receipt.....0018 00-1  
 Unit Repair; Tools; Special Tools; Test, Measurement and Diagnostic Equipment  
 (TMDE); and Support Equipment.....0017 00-1  
 Unit Troubleshooting Procedures .....0009 00-1  
 Unpacking the Equipment.....0005 00-2  
 Unusual Conditions, Operation Under .....0006 00-1  
 Usual Conditions, Operation Under .....0005 00-1  
 Use, Assembly and Preparation for .....0005 00-4  
 Use of Major Components, Description and .....0004 00-1

**Subject**

**WP Sequence No. - Page No.**

**V**

Vent Fitting Assembly (Maintenance) .....	0025 00-1
Vent Fitting Assembly (Operation) .....	0005 00-6
Vent Fitting Assembly Coupling and Dust Cap Gasket Replacement .....	0014 00-1

**W**

Warning Summary .....	a
Windy Conditions, Operation in .....	0006 00-2



By Order of the Secretary of the Army:

Official:



JOEL B. HUDSON

*Administrative Assistant to the  
Secretary of the Army*

0132303

ERIC K. SHINSEKI  
*General, United States Army  
Chief of Staff*

To be distributed in accordance with the initial distribution number (IDN) 256705 requirements for TM 10-5430-243-12&P.





**These are the instructions for sending an electronic 2028**

The following format must be used if submitting an electronic 2028. The subject line must be exactly the same and all fields must be included; however, only the following fields are mandatory: 1, 3, 4, 5, 6, 7, 8, 9, 10, 13, 15, 16, 17 and 27.

**From:** "Whomever" [whomever@avma27.army.mil](mailto:whomever@avma27.army.mil)  
**To:** [tacom-tech-pubs@tacom.army.mil](mailto:tacom-tech-pubs@tacom.army.mil)

**Subject DA Form 2028**

1. **From:** Joe Smith
2. **Unit:** home
3. **Address:** 4300 Park
4. **City:** Hometown
5. **St:** MO
6. **Zip:** 77777
7. **Date Sent:** 19-OCT-93
8. **Pub no:** 55-1915-200-10
9. **Pub Title:** TM
10. **Publication Date:** 11-APR-88
11. **Change Number:** 12
12. **Submitter Rank:** MSG
13. **Submitter Fname:** Joe
14. **Submitter Mname:** T
15. **Submitter Lname:** Smith
16. **Submitter Phone:** 123-123-1234
17. **Problem:** 1
18. **Page:** 1
19. **Paragraph:** 3
20. **Line:** 4
21. **NSN:** 5
22. **Reference:** 6
23. **Figure:** 7
24. **Table:** 8
25. **Item:** 9
26. **Total:** 123
27. **Text:**

This is the text for the problem below line 27.



<b>RECOMMENDED CHANGES TO PUBLICATIONS AND BLANK FORMS</b>	Use Part II (reverse) for Repair Parts and Special Tool Lists (RPSTL) and Supply Catalogs/Supply Manuals (SC/SM).	DATE
For use of this form, see AR 25-30; the proponent agency is OAASA		

<b>TO:</b> (Forward to proponent of publication or form) (Include ZIP Code)	<b>FROM:</b> (Activity and location) (Include ZIP Code)
---	---

**PART I - ALL PUBLICATIONS (EXCEPT RPSTL AND SC/SM) AND BLANK FORMS**

PUBLICATION/FORM NUMBER	DATE	TITLE
TM 10-5430-243-12&P	1 March 2002	Tank, Fabric, Collapsible, Water Storage

ITEM	PAGE	PARA- GRAPH	LINE	FIGURE NO.	TABLE	RECOMMENDED CHANGES AND REASON

\* Reference to line numbers within the paragraph or subparagraph.

TYPED NAME, GRADE OR TITLE	TELEPHONE EXCHANGE/AUTOVON, PLUS EXTENSION	SIGNATURE

<b>TO:</b> <i>(Forward direct to addressee listed in publication)</i>	<b>FROM:</b> <i>(Activity and location) (Include ZIP Code)</i>	DATE
---	--	------

**PART II - REPAIR PARTS AND SPECIAL TOOL LISTS AND SUPPLY CATALOGS/SUPPLY MANUALS**

PUBLICATION NUMBER			DATE		TITLE			
PAGE NO.	COLM NO.	LINE NO.	NATIONAL STOCK NUMBER	REFERENCE NO.	FIGURE NO.	ITEM NO.	TOTAL NO. OF MAJOR ITEMS SUPPORTED	RECOMMENDED ACTION

**PART III - REMARKS** *(Any general remarks or recommendations, or suggestions for improvement of publications and blank forms. Additional blank sheets may be used if more space is needed.)*

TYPED NAME, GRADE OR TITLE	TELEPHONE EXCHANGE/AUTOVON, PLUS EXTENSION	SIGNATURE
----------------------------	--	-----------

<b>RECOMMENDED CHANGES TO PUBLICATIONS AND BLANK FORMS</b>						Use Part II ( <i>reverse</i> ) for Repair Parts and Special Tool Lists (RPSTL) and Supply Catalogs/Supply Manuals (SC/SM).			DATE	
For use of this form, see AR 25-30; the proponent agency is OAASA										
TO: ( <i>Forward to proponent of publication or form</i> ) ( <i>Include ZIP Code</i> )						FROM: ( <i>Activity and location</i> ) ( <i>Include ZIP Code</i> )				
<b>PART I - ALL PUBLICATIONS (EXCEPT RPSTL AND SC/SM) AND BLANK FORMS</b>										
PUBLICATION/FORM NUMBER						DATE		TITLE		
TM 10-5430-243-12&P						1 March 2002		Tank, Fabric, Collapsible, Water Storage		
ITEM	PAGE	PARA-GRAPH	LINE	FIGURE NO.	TABLE	RECOMMENDED CHANGES AND REASON				
<i>* Reference to line numbers within the paragraph or subparagraph.</i>										
TYPED NAME, GRADE OR TITLE					TELEPHONE EXCHANGE/AUTOVON, PLUS EXTENSION			SIGNATURE		

<b>TO:</b> <i>(Forward direct to addressee listed in publication)</i>	<b>FROM:</b> <i>(Activity and location) (Include ZIP Code)</i>	DATE
---	--	------

**PART II - REPAIR PARTS AND SPECIAL TOOL LISTS AND SUPPLY CATALOGS/SUPPLY MANUALS**

PUBLICATION NUMBER			DATE		TITLE			
PAGE NO.	COLM NO.	LINE NO.	NATIONAL STOCK NUMBER	REFERENCE NO.	FIGURE NO.	ITEM NO.	TOTAL NO. OF MAJOR ITEMS SUPPORTED	RECOMMENDED ACTION

**PART III - REMARKS** *(Any general remarks or recommendations, or suggestions for improvement of publications and blank forms. Additional blank sheets may be used if more space is needed.)*

TYPED NAME, GRADE OR TITLE	TELEPHONE EXCHANGE/AUTOVON, PLUS EXTENSION	SIGNATURE
----------------------------	--	-----------

<b>RECOMMENDED CHANGES TO PUBLICATIONS AND BLANK FORMS</b>  For use of this form, see AR 25-30; the proponent agency is OAASA	Use Part II ( <i>reverse</i> ) for Repair Parts and Special Tool Lists (RPSTL) and Supply Catalogs/Supply Manuals (SC/SM).	DATE
---	--	------

<b>TO:</b> ( <i>Forward to proponent of publication or form</i> ) ( <i>Include ZIP Code</i> )	<b>FROM:</b> ( <i>Activity and location</i> ) ( <i>Include ZIP Code</i> )
---	---

**PART I - ALL PUBLICATIONS (EXCEPT RPSTL AND SC/SM) AND BLANK FORMS**

PUBLICATION/FORM NUMBER TM 10-5430-243-12&P	DATE 1 March 2002	TITLE Tank, Fabric, Collapsible, Water Storage
--	----------------------	---

ITEM	PAGE	PARA- GRAPH	LINE	FIGURE NO.	TABLE	RECOMMENDED CHANGES AND REASON

*\* Reference to line numbers within the paragraph or subparagraph.*

TYPED NAME, GRADE OR TITLE	TELEPHONE EXCHANGE/AUTOVON, PLUS EXTENSION	SIGNATURE
----------------------------	---	-----------

<b>TO:</b> (Forward direct to addressee listed in publication)	<b>FROM:</b> (Activity and location) (Include ZIP Code)	DATE
--	---	------

**PART II - REPAIR PARTS AND SPECIAL TOOL LISTS AND SUPPLY CATALOGS/SUPPLY MANUALS**

PUBLICATION NUMBER			DATE	TITLE				
PAGE NO.	COLM NO.	LINE NO.	NATIONAL STOCK NUMBER	REFERENCE NO.	FIGURE NO.	ITEM NO.	TOTAL NO. OF MAJOR ITEMS SUPPORTED	RECOMMENDED ACTION

**PART III - REMARKS** (Any general remarks or recommendations, or suggestions for improvement of publications and blank forms. Additional blank sheets may be used if more space is needed.)

TYPED NAME, GRADE OR TITLE	TELEPHONE EXCHANGE/AUTOVON, PLUS EXTENSION	SIGNATURE
----------------------------	--	-----------



## The Metric System and Equivalents

### Linear Measure

1 centimeter = 10 millimeters = .39 inch  
 1 decimeter = 10 centimeters = 3.94 inches  
 1 meter = 10 decimeters = 39.37 inches  
 1 dekameter = 10 meters = 32.8 feet  
 1 hectometer = 10 dekameters = 328.08 feet  
 1 kilometer = 10 hectometers = 3,280.8 feet

### Weights

1 centigram = 10 milligrams = .15 grain  
 1 decigram = 10 centigrams = 1.54 grains  
 1 gram = 10 decigrams = .035 ounce  
 1 dekagram = 10 grams = .35 ounce  
 1 hectogram = 10 dekagrams = 3.52 ounces  
 1 kilogram = 10 hectograms = 2.2 pounds  
 1 quintal = 100 kilograms = 220.46 pounds  
 1 metric ton = 10 quintals = 1.1 short tons

### Liquid Measure

1 centiliter = 10 milliliters = .34 fl. ounce  
 1 deciliter = 10 centiliters = 3.38 fl. ounces  
 1 liter = 10 deciliters = 33.81 fl. ounces  
 1 dekaliter = 10 liters = 2.64 gallons  
 1 hectoliter = 10 dekaliters = 26.42 gallons  
 1 kiloliter = 10 hectoliters = 264.18 gallons

### Square Measure

1 sq. centimeter = 100 sq. millimeters = .155 sq. inch  
 1 sq. decimeter = 100 sq. centimeters = 15.5 sq. inches  
 1 sq. meter (centare) = 100 sq. decimeters = 10.76 sq. feet  
 1 sq. dekameter (are) = 100 sq. meters = 1,076.4 sq. feet  
 1 sq. hectometer (hectare) = 100 sq. dekameters = 2.47 acres  
 1 sq. kilometer = 100 sq. hectometers = .386 sq. mile

### Cubic Measure

1 cu. centimeter = 1000 cu. millimeters = .06 cu. inch  
 1 cu. decimeter = 1000 cu. centimeters = 61.02 cu. inches  
 1 cu. meter = 1000 cu. decimeters = 35.31 cu. feet

## Approximate Conversion Factors

To change	To	Multiply by	To change	To	Multiply by
inches	centimeters	2.540	ounce-inches	newton-meters	.007062
feet	meters	.305	centimeters	inches	.394
yards	meters	.914	meters	feet	3.280
miles	kilometers	1.609	meters	yards	1.094
square inches	square centimeters	6.451	kilometers	miles	.621
square feet	square meters	.093	square centimeters	square inches	.155
square yards	square meters	.836	square meters	square feet	10.764
square miles	square kilometers	2.590	square meters	square yards	1.196
acres	square hectometers	.405	square kilometers	square miles	.386
cubic feet	cubic meters	.028	square hectometers	acres	2.471
cubic yards	cubic meters	.765	cubic meters	cubic feet	35.315
fluid ounces	milliliters	29.573	cubic meters	cubic yards	1.308
pints	liters	.473	milliliters	fluid ounces	.034
quarts	liters	.946	liters	pints	2.113
gallons	liters	3.785	liters	quarts	1.057
ounces	grams	28.349	liters	gallons	.264
pounds	kilograms	.454	grams	ounces	.035
short tons	metric tons	.907	kilograms	pounds	2.205
pound-feet	newton-meters	1.356	metric tons	short tons	1.102
pound-inches	newton-meters	.11296			

## Temperature (Exact)

°F	Fahrenheit temperature	5/9 (after subtracting 32)	Celsius temperature	°C
----	------------------------	----------------------------	---------------------	----

